

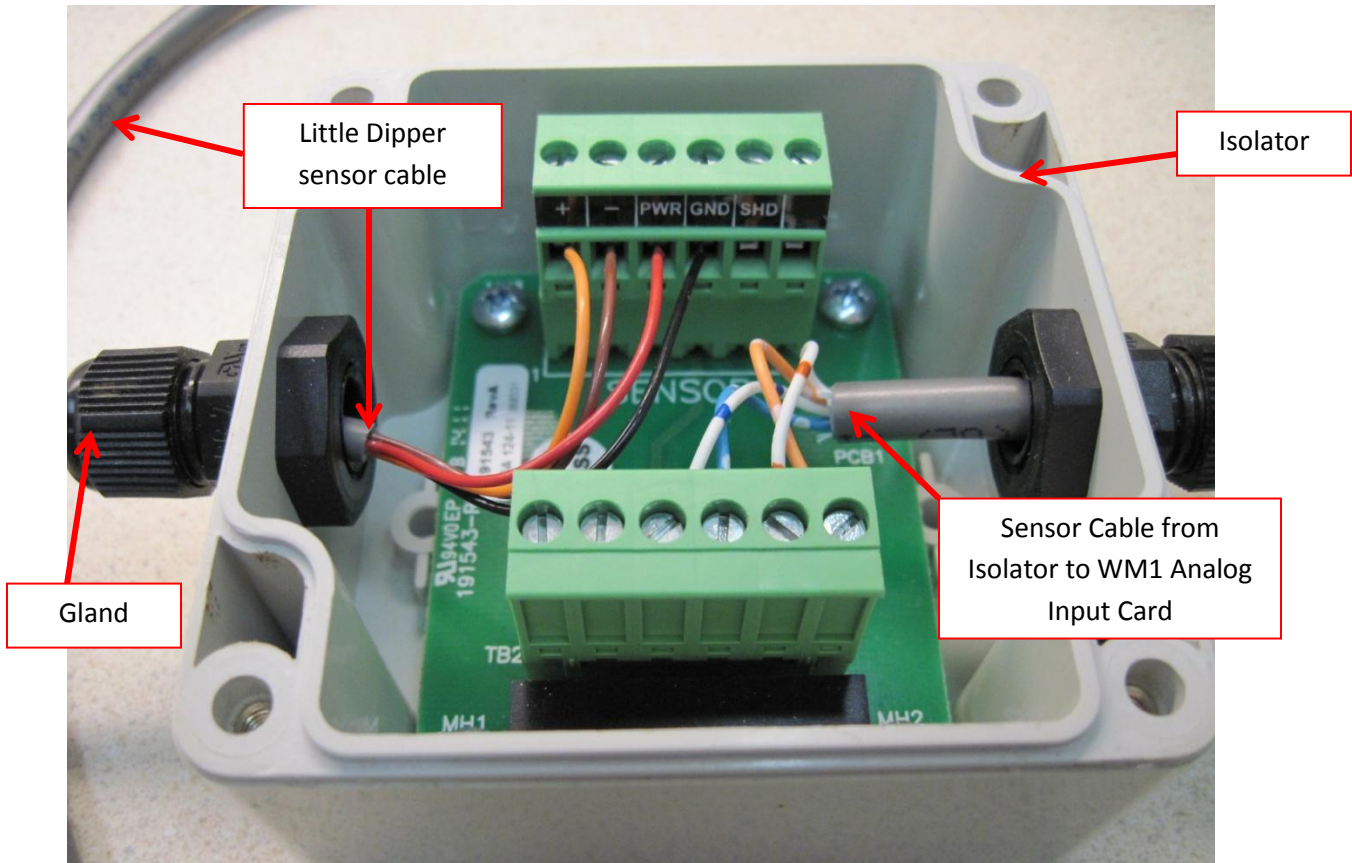

Troubleshooting the Little Dipper

There are two methods used to connect the Little Dipper sensor cable to the Isolator. Either the sensor cable goes through a gland or a circular multi-pole threaded connector is used.

- 1) The Little Dipper sensor cable goes through a gland in the Isolator as shown below.



2) The Little Dipper sensor cable is terminated with a multi-pole connector which mates to a matching threaded connector in the Isolator shown below.

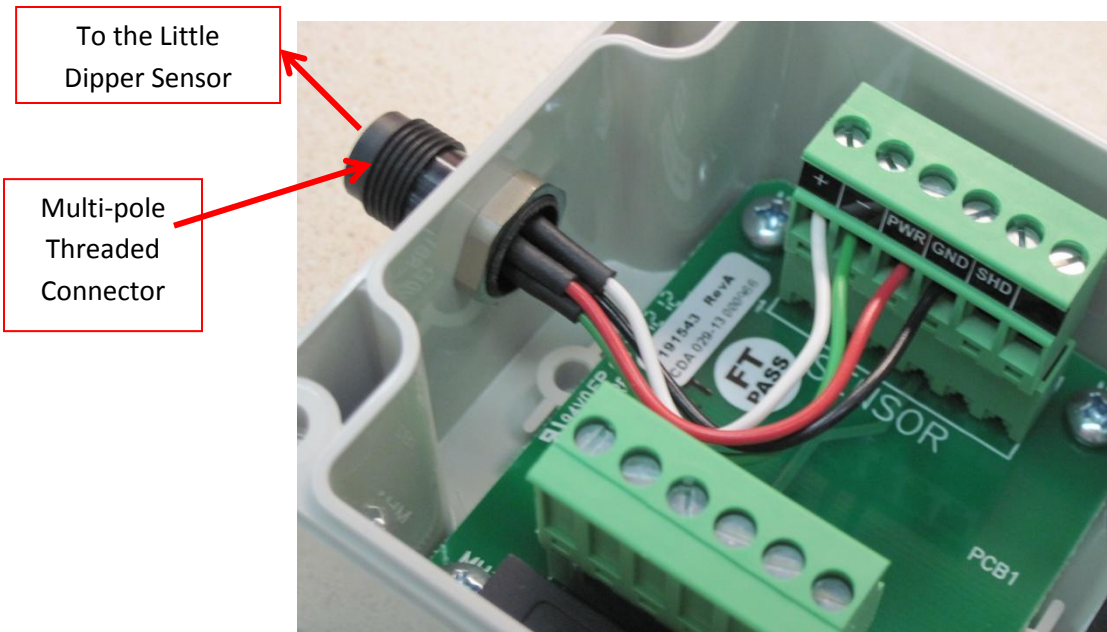

Regardless of how the Little Dipper Sensor connects to the Isolator, the Isolator is always wired to the Analog Input Card (inside the WebMaster One Controller) as shown below.

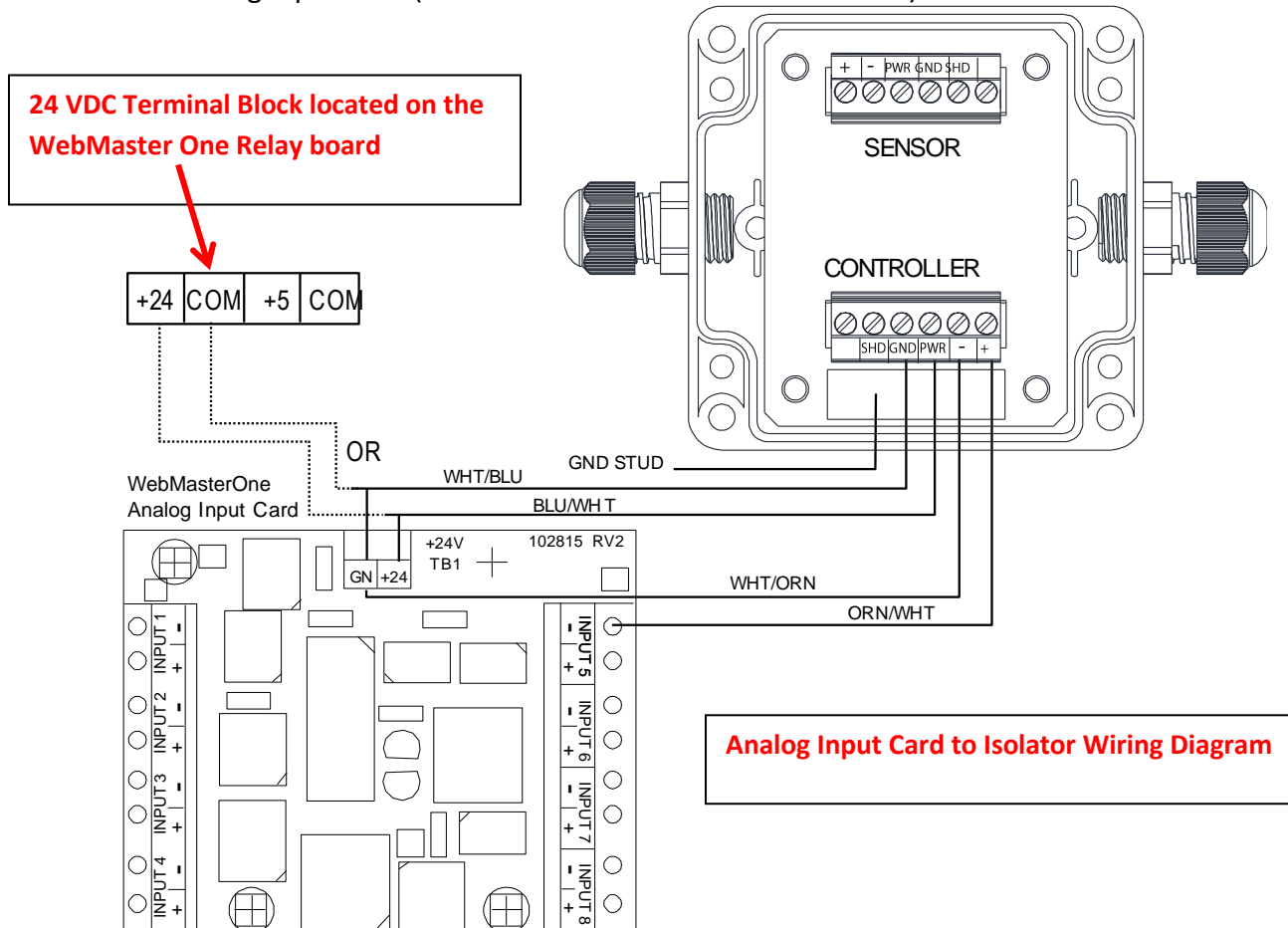

1) Make sure the Analog Inputs are good on the Analog Input (AI) card:

- Power down the controller.
- Measure resistance (in ohms) between the AI (-) terminals and the GND terminal (located on the top center/left of the AI card).
- You should measure 30 to 35 ohms across each (-) terminal and GND. If not, that particular AI input is no good. If you have too many faulty AI's to support your application, obtain a replacement AI card Walchem p/n 191042.
- If you have enough functioning AI's, continue to Step 2.

2) Check mA value coming into the AI card from the Isolator:

- Power down the controller.
- Disconnect the ORN/WHT wire going to the AI card (-) terminal.
- Set the multimeter to mA and put it in series between the AI (-) terminal and the disconnected ORN/WHT wire.
- Power up the controller.
- The mA value on the multimeter should match the mA value displayed in the WebMaster Controller. Document the multimeter reading and the WebMaster Controller reading.
 - Multimeter reading: _____mA
 - WebMaster reading: _____mA
 - If the two readings are within 0.5 mA of each other, continue to Step 3.
 - If the two readings are within 1 to 2 mA of each other, go to the WebMaster Analog Input menu, press the **Reset Defaults** button for that particular AI. Re-check the above two readings.
 - If the two readings are 3 to 4 mA, or greater, of each other, continue to Step 3.

3) Check VDC value going to the Isolator:

- Power up the controller.
- Set the multimeter to VDC and measure across the PWR and GND terminals in the isolator, on the CONTROLLER terminal strip. You should measure 24 VDC. If you do not measure 24 VDC, check the following:
 - Make sure that the wiring is connected as show in the **Analog Input Card to Isolator Wiring Diagram**.
 - Make sure the insulation on the wiring is not causing a bad contact in the terminal.
 - If the measurement is still not 24 VDC:
 - Measure VDC coming out of the WebMaster controller. Depending on how the wiring has been done, this may be at the **Analog Input card**, or at the **24 VDC Terminal Block** located on the Relay board.
 - **Analog Input card**, the GND and +24 terminals.
 - Multimeter reading: _____VDC
 - **24 VDC Terminal Block**, the +24 and COM terminals.
 - Multimeter reading: _____VDC

- If you do not measure 24 VDC at either the **Analog Input card** or at the **24 VDC Terminal Block**, power down the controller, disconnect the WHT/BLU and BLU/WHT wires from the Isolator CONTROLLER terminal strip. Power up, and repeat the above VDC measurements.
- If you still do not measure 24 VDC, then please contact Walchem at 508-429-1110.
- If you do measure 24 VDC, continue to Step 4.

4) Check VDC value going to the Little Dipper:

- Power down the controller.
- Unthread the SENSOR connector. This completely disconnects the Little Dipper SENSOR from the Isolator. Or, if the Little Dipper SENSOR cable goes through the gland, then disconnect the ORN, BRN, RED and BLK wires from the SENSOR terminal strip inside the Isolator.
- Reconnect the WHT/BLU and BLU/WHT wires to the Isolator CONTROLLER terminal strip.
- Power up the controller.
- Set the multimeter to VDC and measure across the PWR and GND terminals in the Isolator, on the SENSOR terminal strip. You should measure 24 VDC.
 - If this measurement is not 24 VDC, obtain a replacement Isolator, Walchem p/n 191544 (this Isolator accepts the Little Dipper sensor cable through the gland) or Walchem p/n 191544-C (this isolator accepts the Little Dipper sensor cable that is terminated with a multi-pole connector which mates to a matching threaded connector in the Isolator).
 - If you measure 24 VDC, continue to Step 5.

5) Check mA value coming back from the Little Dipper:

- Power down the controller.
- Thread the SENSOR connector back into the isolator. Disconnect the wires going to the (+) and the (-) on the SENSOR terminal strip inside the Isolator. Or, if the Little Dipper SENSOR cable goes through the gland, then re-connect only the RED and BLK Little Dipper sensor wires as follows:
 - RED wire to the PWR SENSOR terminal inside the Isolator
 - BLK wire to the GND SENSOR terminal inside the Isolator
- Power up the controller.
- Set the multimeter to mA and measure across the disconnected (+) and (-) wires coming from the Little Dipper sensor.
- You should get a mA reading between 4 and 20 mA. A reading of 0.00 mA could mean a faulty Little Dipper sensor.