

**OnGuard™**

**P900 CONTROLLER**  
PERFORMANCE-BASED CONTROL



## **Notice**

© 2021 WALCHEM, Iwaki America Incorporated (hereinafter “Walchem”)  
5 Boynton Road, Holliston, MA 01746 USA  
(508) 429-1110  
All Rights Reserved  
Printed in USA

## **Proprietary Material**

The information and descriptions contained herein are the property of WALCHEM. Such information and descriptions may not be copied or reproduced by any means, or disseminated or distributed without the express prior written permission of WALCHEM, 5 Boynton Road, Holliston, MA 01746.

This document is for information purposes only and is subject to change without notice.

## **Statement of Limited Warranty**

WALCHEM warrants equipment of its manufacture, and bearing its identification to be free from defects in workmanship and material for a period of 24 months for electronics and 12 months for mechanical parts and electrodes from date of delivery from the factory or authorized distributor under normal use and service and otherwise when such equipment is used in accordance with instructions furnished by WALCHEM and for the purposes disclosed in writing at the time of purchase, if any. WALCHEM’s liability under this warranty shall be limited to replacement or repair, F.O.B. Holliston, MA U.S.A. of any defective equipment or part which, having been returned to WALCHEM, transportation charges prepaid, has been inspected and determined by WALCHEM to be defective. Replaceable elastomeric parts and glass components are expendable and are not covered by any warranty.

THIS WARRANTY IS IN LIEU OF ANY OTHER WARRANTY, EITHER EXPRESS OR IMPLIED, AS TO DESCRIPTION, QUALITY, MERCHANTABILITY, FITNESS FOR ANY PARTICULAR PURPOSE OR USE, OR ANY OTHER MATTER.

180699 Rev. J December 2021

# Contents

1.0 INTRODUCTION .....	1
2.0 SPECIFICATIONS .....	2
2.1 Measurement Performance .....	2
2.2 Electrical: Input/Output .....	4
2.3 Mechanical .....	6
2.4 Variables and their Limits.....	7
3.0 UNPACKING & INSTALLATION .....	11
3.1 Unpacking the unit.....	11
3.2 Mounting the electronic enclosure .....	11
3.3 Sensor Installation .....	11
3.4 Icon Definitions .....	14
3.5 Electrical installation .....	15
4.0 FUNCTION OVERVIEW .....	33
4.1 Front Panel .....	33
4.2 Touchscreen .....	33
4.3 Icons .....	33
4.4 Startup .....	35
4.5 Shut Down .....	44
5.0 OPERATION using the touchscreen.....	44
5.1 Alarms Menu .....	44
5.2 Inputs Menu .....	44
5.2.1 Contacting Conductivity .....	48
5.2.2 Electrodeless Conductivity .....	48
5.2.3 Temperature .....	49
5.2.4 pH.....	49
5.2.5 ORP.....	50
5.2.6 Disinfection.....	50
5.2.7 Generic Sensor .....	51
5.2.8 Corrosion Input.....	52
5.2.9 Corrosion Imbalance Input .....	53
5.2.10 Transmitter Input and AI Monitor Input .....	54
5.2.11 Fluorometer Input .....	54
5.2.12 Analog Flowmeter Input.....	55
5.2.13 Analog Tank Level Input .....	55
5.2.14 DI State.....	56
5.2.15 Flow Meter, Contactor Type .....	56
5.2.16 Flow Meter, Paddlewheel Type.....	57
5.2.17 Feed Monitor .....	58
5.2.18 DI Counter Input .....	59
5.2.19 Remote Modbus DI State.....	60
5.2.20 Virtual Input – Calculation.....	61
5.2.21 Virtual Input – Redundant.....	62
5.2.22 Virtual Input – Raw Value .....	63

5.2.23	Virtual Input - Disturbance .....	63
5.2.24	Remote Modbus Sensor Virtual Input .....	65
5.3	Outputs Menu .....	65
5.3.1	Relay, Any Control Mode .....	66
5.3.2	Relay, On/Off Control Mode .....	66
5.3.3	Relay, Flow Timer Control Mode .....	67
5.3.4	Relay, Bleed and Feed Control Mode.....	67
5.3.5	Relay, Bleed then Feed Control Mode.....	68
5.3.6	Relay, Percent Timer Control Mode.....	68
5.3.7	Relay, Biocide Timer Control Mode .....	68
5.3.8	Relay, Alarm Output Mode.....	70
5.3.9	Relay, Time Proportional Control Mode.....	70
5.3.10	Relay, Intermittent Sampling Control Mode .....	71
5.3.11	Relay, Manual Mode.....	72
5.3.12	Relay, Pulse Proportional Control Mode.....	72
5.3.13	Relay, PID Control Mode .....	73
5.3.14	Relay, Dual Set Point Mode.....	75
5.3.15	Relay, Timer Control Mode .....	76
5.3.16	Relay, Probe Wash Control Mode .....	77
5.3.17	Relay, Spike Control Mode .....	78
5.3.18	Relay Output, Pulse Mass Balance Mode.....	80
5.3.19	Relay, Target PPM Control Mode.....	81
5.3.20	Relay, PPM by Volume Control Mode .....	82
5.3.21	Relay, Mass Balance Control Mode.....	83
5.3.22	Relay, Counter Timer Control Mode .....	84
5.3.23	Relay Output, On/Off Disturbance Control Mode .....	85
5.3.24	Relay Output, Volumetric Blending Control Mode .....	86
5.3.25	Relay, Dual Switch Control Mode.....	86
5.3.26	Relay, Boolean Logic Control Mode.....	87
5.3.27	Relay or Analog Output, Lag Control Mode .....	88
5.3.28	Relay Output, Flow Meter Ratio Control Mode.....	94
5.3.29	Relay or Analog Output, Disturbance Variable Control Mode.....	95
5.3.30	Analog Output, Proportional Control Mode.....	96
5.3.31	Analog Output, Mass Balance Mode .....	96
5.3.32	Analog Output, PID Control Mode .....	98
5.3.32	Analog Output, Manual Mode.....	100
5.3.33	Analog Output, Retransmit Mode .....	100
5.4	Configuration Menu .....	101
5.4.1	Global Settings .....	101
5.4.2	Security Settings.....	101
5.4.3	Ethernet Settings.....	101
5.4.4	Ethernet Details.....	102
5.4.5	WiFi Settings .....	102
5.4.6	WiFi Details .....	103
5.4.7	Remote Communications (Modbus and BACnet).....	104
5.4.8	Email Report Settings.....	105
5.4.9	Display Settings.....	106
5.4.10	File Utilities .....	106
5.4.11	Controller Details.....	107

5.5 HOA Menu .....	108
5.6 Graph Menu .....	108
6.0 OPERATION using Ethernet.....	109
6.1 Connecting to a LAN.....	109
6.1.1 Using DHCP .....	109
6.1.2 Using a fixed IP Address .....	109
6.2 Connecting Directly to a Computer.....	110
6.3 Navigating the web pages .....	110
6.4 Graphs Webpage.....	110
6.5 Software Upgrade.....	111
6.6 Notepad Menu .....	112
6.7 Remote Sensor Calibration .....	112
7.0 MAINTENANCE.....	112
7.1 Electrode Cleaning.....	112
7.2 Replacing the Fuse Protecting Powered Relays.....	113
8.0 TROUBLESHOOTING.....	113
8.1 Calibration Failure .....	113
8.1.1 Contacting Conductivity Sensors .....	113
8.1.2 Electrodeless Conductivity Sensors.....	114
8.1.3 pH Sensors.....	114
8.1.4 ORP Sensors .....	114
8.1.5 Disinfection Sensors.....	114
8.1.6 Analog Inputs .....	115
8.1.7 Temperature Sensors .....	115
8.1.8 Corrosion Inputs.....	115
8.2 Alarm Messages .....	115
8.3 Procedure for Evaluation of Conductivity Electrode .....	120
8.4 Procedure for Evaluation of the pH/ORP Electrode .....	120
8.5 Diagnostic Lights .....	121
9.0 Spare Parts Identification.....	122
10.0 Service Policy .....	178

# 1.0 INTRODUCTION

---

The Walchem OnGuard™ P900 Series controllers offer a high level of flexibility in controlling water treatment applications.

- There are four slots that accept a variety of Input/Output Modules, which provides unparalleled versatility. Dual sensor input modules are available that are compatible with a variety of sensors (two sensors per module):
  - » Contacting conductivity
  - » Electrodeless conductivity
  - » pH
  - » ORP
  - » Any Walchem disinfection sensor
  - » Generic sensor (Ion Selective Electrodes or any type of sensor with a linear voltage output between -2 VDC and 2 VDC)
- Three analog (4-20 mA) input modules with two, four or six input circuits is also available for use with 2,3 or 4-wire transmitters.
- Two other modules feature two or four isolated analog outputs that may be installed to retransmit sensor input signals to a chart recorder, datalogger, PLC or other device. They may also be connected to valves, actuators or metering pumps for linear proportional control or PID control.
- Another module combines two analog (4-20 mA) inputs and four analog outputs.
- Eight Virtual Inputs are configurable in the software, to either allow for calculations based on two real inputs, or to allow to compare values from two sensors to provide redundancy.
- Eight relay outputs may be set to a variety of control modes:
  - » On/Off set point control
  - » Time Proportional control
  - » Pulse Proportional control (when purchased with Pulse solid state opto outputs)
  - » Mass Balance
  - » PID control (when purchased with Pulse solid state opto outputs)
  - » Lead/Lag control of up to 6 relays
  - » Dual set point
  - » Timer
  - » Bleed or Feed based on a Water Contactor or Paddlewheel flow meter input
  - » Feed and Bleed
  - » Feed and Bleed with Lockout
  - » Feed as a percent of Bleed
  - » Feed as a percent of elapsed time
  - » Daily, Weekly, 2-week or 4-week Biocide timers with pre-bleed and post-add lockout of bleed
  - » Intermittent sampling for boilers with proportional blowdown, controlling on a trapped sample
  - » Always on unless interlocked
  - » Probe Wash timer
  - » Spike to alternate set point on timed basis
  - » Target PPM
  - » PPM Volume
  - » Dual Switch
  - » Boolean Logic
  - » Diagnostic Alarm triggered by:
    - High or Low sensor reading
    - No Flow
    - Relay output timeout
    - Sensor error

Relays are available in several combinations of powered relays, dry contact relays, and pulse solid state opto relays.

Eight Virtual Outputs are configurable in the software, using most of the possible relay or analog output control algorithms, that may be used to interlock or activate actual control outputs.

The standard Ethernet feature provides remote access to the controller’s programming via a PC connected directly, via a local area network, or via Walchem’s Fluent account management server. It also allows emailing of datalog files (in CSV format, compatible with spreadsheets like Excel) and alarms, to up to eight email addresses. The Modbus TCP and BACnet remote communications options allow communication with PC-based applications, HMI/SCADA programs, Building Energy Management systems, Distributed Control Systems (DCS), as well as stand-alone HMI devices.

Two optional WiFi cards are available, one which allows simultaneous Ethernet and WiFi communications, and one that increases security by disabling Ethernet when WiFi is enabled. The WiFi can be set to Infrastructure Mode to provide all the Ethernet functions above, or Ad-Hoc Mode to allow access to the programming wirelessly.

Our USB features provide the ability to upgrade the software in the controller to the latest version. The Config file feature allows you to save all the set points from a controller onto a USB flash disk, and then import them into another controller, making the programming of multiple controllers fast and easy. The data logging feature allows you to save the sensor readings and relay activation events to a USB flash disk.

## 2.0 SPECIFICATIONS

---

### 2.1 Measurement Performance

<b>pH</b>		<b>ORP/ISE</b>	
Range	-2 to 16 pH units	Range	-1500 to 1500 mV
Resolution	0.01 pH units	Resolution	0.1 mV
Accuracy	± 0.01% of reading	Accuracy	± 1 mV
<b>Disinfection Sensors</b>			
Range (mV)	-2000 to 1500 mV	Range (ppm)	0-2 ppm to 0-20,000 ppm
Resolution (mV)	0.1 mV	Resolution (ppm)	Varies with range and slope
Accuracy (mV)	± 1 mV	Accuracy (ppm)	Varies with range and slope
<b>100Ω RTD Temperature</b>			
Range	23 to 500°F (-5 to 260°C)		
Resolution	0.1°F (0.1°C)		
Accuracy	± 1% of Reading or ± 1°C, whichever is greater		
<b>1000Ω RTD Temperature</b>			
Range	23 to 500°F (-5 to 260°C)		
Resolution	0.1°F (0.1°C)		
Accuracy	± 1% of Reading or ± 0.3°C , whichever is greater		
<b>10k or 100k Thermistor Temperature</b>			
Range	23 to 194°F (-5 to 90°C)		
Resolution	0.1°F (0.1°C)		
Accuracy	± 1% of Reading or ± 0.3°C, whichever is greater		
<b>Analog (4-20 mA)</b>			
Range	0 to 22 mA		
Resolution	0.01 mA		

Accuracy	± 0.5% of reading	
Range -4 to 500°F (-20 to 260°C)	Range	0 to 22 mA
Resolution 0.1°F (0.1°C)	Resolution	0.01 mA
Accuracy ± 1% of reading	Accuracy	± 0.5% of reading
<b>Corrosion</b>		
<b>Range</b>	<b>Resolution</b>	
0-2 mpy or mm/year	0.001 mpy or mm/year	
0-20 mpy or mm/year	0.01 mpy or mm/year	
0-200 mpy or mm/year	0.1 mpy or mm/year	
<b>0.01 Cell Contacting Conductivity</b>		
Range	0-300 µS/cm	
Resolution	0.01 µS/cm, 0.0001 mS/cm, 0.001 mS/m, 0.0001 S/m, 0.01 ppm	
Accuracy	± 1% of reading or 0.01 µS/cm, whichever is greater	
<b>0.1 Cell Contacting Conductivity</b>		
Range	0-3,000 µS/cm	
Resolution	0.1 µS/cm, 0.0001 mS/cm, 0.01 mS/m, 0.0001 S/m, 0.1 ppm	
Accuracy	± 1% of Reading or 0.1 µS/cm, whichever is greater	
<b>1.0 Cell Contacting Conductivity</b>		
Range	0-30,000 µS/cm	
Resolution	1 µS/cm, 0.001 mS/cm, 0.1 mS/m, 0.0001 S/m, 1 ppm	
Accuracy	± 1% of Reading or 1 µS/cm, whichever is greater	
<b>10.0 Cell Contacting Conductivity</b>		
Range	0-300,000 µS/cm	
Resolution	10 µS/cm, 0.01 mS/cm, 1 mS/m, 0.001 S/m, 10 ppm	
Accuracy	± 1% of Reading or 10 µS/cm, whichever is greater	
<b>Electrodeless Conductivity</b>		
<b>Range</b>	<b>Resolution</b>	<b>Accuracy</b>
500-12,000 µS/cm	1 µS/cm, 0.01 mS/cm, 0.1 mS/m, 0.001 S/m, 1 ppm	1% of reading
3,000-40,000 µS/cm	1 µS/cm, 0.01 mS/cm, 0.1 mS/m, 0.001 S/m, 1 ppm	1% of reading
10,000-150,000 µS/cm	10 µS/cm, 0.1 mS/cm, 1 mS/m, 0.01 S/m, 10 ppm	1% of reading
50,000-500,000 µS/cm	10 µS/cm, 0.1 mS/cm, 1 mS/m, 0.01 S/m, 10 ppm	1% of reading
200,000-2,000,000 µS/cm	100 µS/cm, 0.1 mS/cm, 1 mS/m, 0.1 S/m, 100 ppm	1% of reading



Temperature °C	Range Multiplier
0	181.3
10	139.9
15	124.2
20	111.1
25	100.0
30	90.6
35	82.5
40	75.5
50	64.3
60	55.6
70	48.9

Temperature °C	Range Multiplier
80	43.5
90	39.2
100	35.7
110	32.8
120	30.4
130	28.5
140	26.9
150	25.5
160	24.4
170	23.6
180	22.9

**Note:** Conductivity ranges on page 2 apply at 25°C. At higher temperatures, the range is reduced per the range multiplier chart.

## 2.2 Electrical: Input/Output

<b>Input Power</b>	100 to 240 VAC, 50 or 60 Hz, 13 A maximum
<b>Inputs</b>	
Sensor Input Signals (0 to 8 depending on model code):	
Contacting Conductivity	0.01, 0.1, 1.0, or 10.0 cell constant OR
Electrodeless Conductivity	OR
Disinfection	OR
Amplified pH, ORP or ISE	Requires a preamplified signal. Walchem WEL or WDS series recommended. ±5VDC power available for external preamps.
Each sensor input card contains a temperature input	
Temperature	100 or 1000 ohm RTD, 10K or 100K Thermistor
Analog (4-20 mA) Sensor Input (0 to 24 depending on model code):	2-wire loop powered or self-powered transmitters supported 3 or 4 –wire transmitters supported Two to Six channels per board, depending on model Channel 1, 130 ohm input resistance Channel 2-6, 280 ohm input resistance All channels fully isolated, input and power Available Power: One independent isolated 24 VDC ± 15% supply per channel 1.5 W maximum for each channel
<b>Digital Input Signals (12 standard):</b>	
State-Type Digital Inputs	Electrical: Optically isolated and providing an electrically isolated 12VDC power with a nominal 2.3mA current when the digital input switch is closed Typical response time: < 2 seconds Devices supported: Any isolated dry contact (i.e. relay, reed switch) Types: DI State

Low Speed Counter-Type Digital Inputs	Electrical: Optically isolated and providing an electrically isolated 12VDC power with a nominal 2.3mA current when the digital input switch is closed 0-20 Hz, 25 msec minimum width Devices supported: Any device with isolated open drain, open collector, transistor or reed switch Types: Contacting Flowmeter, Flow Verify
High Speed Counter-Type Digital Inputs	Electrical: Optically isolated and providing an electrically isolated 12VDC power with a nominal 2.3mA current when the digital input switch is closed, 0-500 Hz, 1.00 msec minimum width. Minimum pulse frequency for the rate to be displayed: 0.17 Hz Devices supported: Any device with isolated open drain, open collector, transistor or reed switch Types: Paddlewheel Flowmeter, DI Counter
<b>Outputs</b>	
Powered mechanical relays (0 to 8 depending on model code):	Pre-powered on circuit board switching line voltage. Two, three or four relays are fused together (depending on model code) as one group, total current for this group must not exceed 6 A (resistive), 1/8 HP (93 W)
Dry contact mechanical relays (0 to 8 depending on model code):	6 A (resistive), 1/8 HP (93 W) Dry contact relays are not fuse protected
Pulse Outputs (0, 2 or 4 depending on model code):	Opto-isolated, Solid State Relay 200mA, 40 VDC Max. VLOWMAX = 0.05V @ 18 mA Accuracy (0-10 Hz): ± 0.5% of Pulse Rate, (10-20 Hz): ± 1.0%, (20-40 Hz): ± 2.0%
4 - 20 mA (0 to 16 depending on model code)	Internally powered, 15 VDC, Fully isolated 600 Ohm max resistive load Resolution 0.0015% of span Accuracy ± 0.5% of reading
<b>Ethernet</b>	10/100 802.3-2005 Auto MDIX support Auto Negotiation
<b>Wi-Fi</b>	Radio Protocol: IEEE 802.11 b/g/n Security Protocols (Ad-Hoc Mode): WPA2-Personal Security Protocols (Infrastructure Mode): WPA/WPA2-Personal, WEP Certifications and Compliance: FCC, IC TELEC, CE/ETSI, RoHS, Wi-Fi Certified
NOTE on Wi-Fi: This equipment has been tested and found to comply with the limits for a Class A digital device, pursuant to part 15 of the FCC Rules. These limits are designed to provide reasonable protection against harmful interference when the equipment is operated in a commercial environment. This equipment generates, uses, and can radiate radio frequency energy and, if not installed and used in accordance with the instruction manual, may cause harmful interference to radio communications. Operation of this equipment in a residential area is likely to cause harmful interference in which case the user will be required to correct the interference at his own expense.	
<b>Agency Approvals:</b>	
Safety	UL 61010-1:2012 3rd Ed + Rev:2016 CSA C22.2 No. 61010-1:2012 3rd Ed. + U1; U2 IEC 61010-1:2010 3rd Ed. EN 61010-1:2010 3rd Ed. BS EN 61010-1:2010 + A1:2019

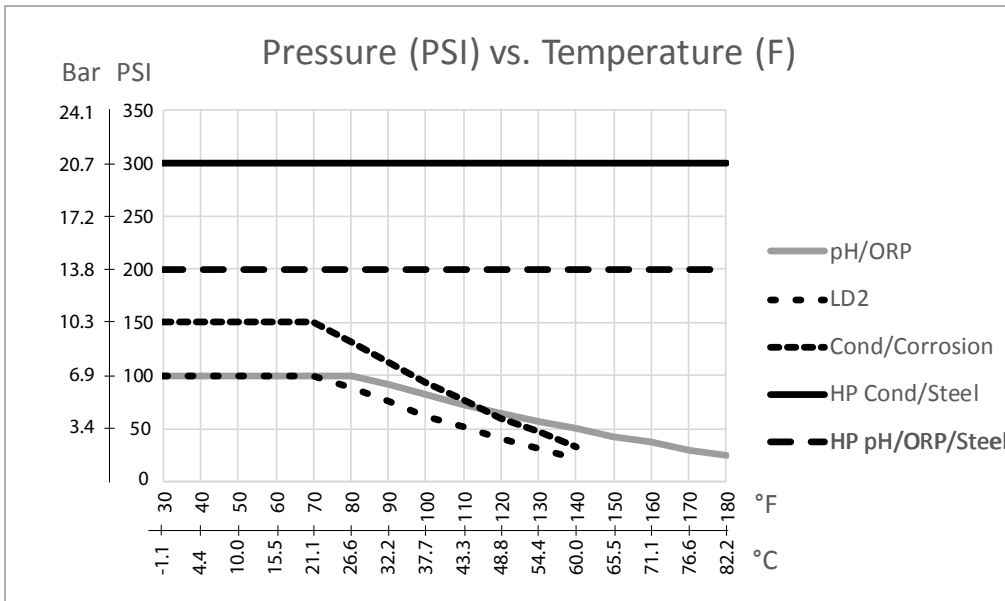
EMC	IEC 61326-1:2012 EN 61326-1:2013 BS EN 61326-1:2013
Note: For EN61000-4-6, EN61000-4-3 the controller met performance criteria B. *Class A equipment: Equipment suitable for use in establishments other than domestic, and those directly connected to a low voltage (100-240 VAC) power supply network which supplies buildings used for domestic purposes.	

## 2.3 Mechanical

Enclosure Material	Polycarbonate
Enclosure Rating	NEMA 4X (IP65)
Dimensions	12.2" W x 13.8" H x 5.4" D (310 mm x 351 mm x 137 mm)
Display	320 x 240 pixel monochrome backlit display with touchscreen
Operating Ambient Temp	-4 to 122 °F (-20 to 50 °C)
Storage Temperature	-4 – 176°F (-20 – 80°C)
Humidity	10 to 90% non-condensing

### Mechanical (Sensors) (\*see graph)

Sensor	Pressure	Temperature	Materials	Process Connections
Electrodeless conductivity	0-150 psi (0-10 bar)*	CPVC: 32-158°F (0 to 70°C)* PEEK: 32-190°F (0 to 88°C)	CPVC, FKM in-line o-ring PEEK, 316 SS in-line adapter	1" NPTM submersion 2" NPTM in-line adapter
pH	0-100 psi (0-7 bar)*	50-158°F (10-70°C)*	CPVC, Glass, FKM o-rings, HDPE, Titanium rod, glass-filled PP tee	1" NPTM submersion 3/4" NPTF in-line tee
ORP	0-100 psi (0-7bar)*	32-158°F (0-70°C)*		
Contacting conductivity (Condensate)	0-200 psi (0-14 bar)	32-248°F (0-120°C)	316SS, PEEK	3/4" NPTM
Contacting conductivity Graphite (Cooling Tower)	0-150 psi (0-10 bar)*	32-158°F (0-70°C)*	Graphite, Glass-filled PP, FKM o-ring	3/4" NPTM
Contacting conductivity SS (Cooling Tower)	0-150 psi (0-10 bar)*	32-158°F (0-70°C)*	316SS, Glass-filled PP, FKM o-ring	3/4" NPTM
Contacting conductivity (Boiler)	0-250 psi (0-17 bar)	32-401°F (0-205°C)	316SS, PEEK	3/4" NPTM
Contacting conductivity (High Pressure Tower)	0-300 psi (0-21 bar)*	32-158°F (0-70°C)*	316SS, PEEK	3/4" NPTM
pH (High Pressure)	0-300 psi (0-21 bar)*	32-275°F (0-135°C)*	Glass, Polymer, PTFE, 316SS, FKM	1/2" NPTM gland
ORP (High Pressure)	0-300 psi (0-21 bar)*	32-275°F (0-135°C)*	Platinum, Polymer, PTFE, 316SS, FKM	1/2" NPTM gland
Free Chlorine/Bromine	0-14.7 psi (0-1 bar)	32-113°F (0-45°C)	PVC, Polycarbonate, silicone rubber, SS, PEEK, FKM, Isoplast	1/4" NPTF Inlet 3/4" NPTF Outlet
Extended pH Range Free Chlorine/Bromine	0-14.7 psi (0-1 bar)	32-113°F (0-45°C)		
Total Chlorine	0-14.7 psi (0-1 bar)	32-113°F (0-45°C)		
Chlorine Dioxide	0-14.7 psi (0-1 bar)	32-131°F (0-55°C)		
Ozone	0-14.7 psi (0-1 bar)	32-131°F (0-55°C)		
Peracetic Acid	0-14.7 psi (0-1 bar)	32-131°F (0-55°C)		
Hydrogen Peroxide	0-14.7 psi (0-1 bar)	32-113°F (0-45°C)		
Corrosion	0-150 psi (0-10 bar)	32-158°F (0-70°C)*	Glass-filled PP, FKM o-ring	3/4" NPTM
Flow switch manifold	0-150 psi (0-10 bar) up to 100°F (38°C)* 0-50 psi (0-3 bar) at 140°F (60°C)	32-140°F (0-60°C)	GFRPP, PVC, FKM, Isoplast	3/4" NPTF
Flow switch manifold (High Pressure)	0-300 psi (0-21 bar)*	32-158°F (0-70°C)*	Carbon steel, Brass, 316SS, FKM	3/4" NPTF



## 2.4 Variables and their Limits

Sensor Input Settings	Low Limit	High Limit
Alarm limits	Low end of sensor range	High end of sensor range
Input alarm dead band	Low end of sensor range	High end of sensor range
Cell constant (conductivity only)	0.01	10
Smoothing Factor	0%	90%
Temp Comp Factor (conductivity linear ATC only)	0%	20.000%
Installation Factor (Electrodeless conductivity only)	0.5	1.5
Cable length	0.1	3,000
PPM conversion factor (only if units = PPM)	0.001	10.000
Default temperature	-20	500
Deadband	Low end of sensor range	High end of sensor range
Calibration Required Alarm	0 days	365 days
Sensor Slope (Generic sensor only)	-1,000,000	1,000,000
Sensor Offset (Generic sensor only)	-1,000,000	1,000,000
Low Range (Generic sensor, Virtual Input)	-1,000,000	1,000,000
High Range (Generic sensor, Virtual Input)	-1,000,000	1,000,000
Constant (Virtual Input only)	10% below Low Range setting	10% above High Range setting
Deviation Alarm (Virtual Input)	10% below Low Range setting	10% above High Range setting
4 mA value (Transmitter, AI Monitor analog input only)	0	100
20 mA value (Transmitter, AI Monitor analog input only)	0	100
Max Sensor Range (Fluorometer analog input only)	0 ppb	100,000 ppb
Dye/Product Ratio (Fluorometer analog input only)	0 ppb/ppm	100 ppb/ppm
Set Flow Total (Flowmeter analog input only)	0	1,000,000,000
Flowmeter Max (Flowmeter analog input only)	0	1,000,000
Input Filter (Flowmeter analog input only)	1 mA	21 mA
Totalizer Alarm (Flowmeter analog input only)	0	2,000,000,000
Min Disturbance (Disturbance Virtual Input only)	Low end of sensor range	High end of sensor range
Max Disturbance (Disturbance Virtual Input only)	Low end of sensor range	High end of sensor range

Value at Min Disturbance (Disturbance Virtual Input only)	0	100
Value at Max Disturbance (Disturbance Virtual Input only)	0	100
Stabilization Time (Corrosion only)	0 hours	999 hours
Electrode Alarm (Corrosion only)	0 days	365 days
Alloy Multiplier (Corrosion only)	0.2	5.0
Tank Capacity	0	1,000,000
Empty At	0 mA	21 mA
Full At	0 mA	21 mA
<b>Digital flow meter input settings</b>	<b>Low Limit</b>	<b>High Limit</b>
Totalizer alarm	0	2,000,000,000
Volume/contact for units of Gallons or Liters	1	100,000
Volume/contact for units of m <sup>3</sup>	0.001	1,000
K Factor for units of Gallons or Liters	0.01	100,000
K Factor for units of m <sup>3</sup>	1	1,000,000
Paddlewheel rate alarm limits	0	High end of sensor range
Paddlewheel rate alarm deadband	0	High end of sensor range
Smoothing Factor	0%	90%
Set Flow Total	0	1,000,000,000
<b>Feed Monitor Input Settings</b>	<b>Low Limit</b>	<b>High Limit</b>
Totalizer Alarm	0 vol. units	1,000,000 vol. units
Set Flow Total	0 vol. units	1,000,000,000 vol. units
Flow Alarm Delay	00:10 Minutes	59:59 Minutes
Flow Alarm Clear	1 Contact	100,000 Contacts
Dead Band	0%	90%
Reprime Time	00:00 Minutes	59:59 Minutes
Volume/Contact	0.001 ml	1,000.000 ml
Smoothing Factor	0%	90%
<b>Counter Input Settings</b>	<b>Low Limit</b>	<b>High Limit</b>
DI Counter Rate Alarms	0	30,000
DI Counter Rate Deadband	0	30,000
Totalizer Alarm	0	2,000,000,000
Set Total	0	2,000,000,000
Units per Pulse	0.001	1,000
Smoothing Factor	0%	90%
<b>Remote Modbus Input Settings</b>	<b>Low Limit</b>	<b>High Limit</b>
Alarm Limits	Low end of defined range	High end of defined range
Deadband	Low end of defined range	High end of defined range
Low Range	-1,000,000	1,000,000
High Range	-1,000,000	1,000,000
Reply Timeout	1 second	15 seconds
Remote Register	0	65535
Update Period	00:01 MM:SS	59:59 MM:SS
Timeout Alarm Delay	00:10 MM:SS	59:59 MM:SS
<b>Relay output settings</b>	<b>Low Limit</b>	<b>High Limit</b>
Output Limit Time	1 second	86,400 seconds (0 = unlimited)
Hand Time Limit	1 second	86,400 seconds (0 = unlimited)
Daily Max Time	00:01 MM:SS	23:59 MM:SS (0 = unlimited)

Min Relay Cycle	0 seconds	300 seconds
Set Point	Low end of sensor range	High end of sensor range
Spike Set Point (Spike mode)	Low end of sensor range	High end of sensor range
Onset Time (Spike mode)	0 seconds	23:59:59 HH:MM:SS
Duty Cycle Period (On/Off, Spike, Dual Setpoint modes)	0:00 minutes	59:59 minutes
Duty Cycle (On/Off, Spike, Dual Setpoint modes)	0%	100%
On Delay Time (Manual, On/Off, Dual Setpoint modes, Dual Switch, Alarm modes, Boolean Logic)	0 seconds	23:59:59 HH:MM:SS
Off Delay Time (Manual, On/Off, Dual Setpoint modes, Dual Switch, Alarm modes, Boolean Logic)	0 seconds	23:59:59 HH:MM:SS
Dead Band	Low end of sensor range	High end of sensor range
Feed duration (Flow Timer, Counter Timer mode)	0 seconds	86,400 seconds
Accumulator Volume (Flow Timer, Target PPM, PPM Volume, Volumetric Blend, Flow Meter Ratio modes)	1	1,000,000
Accumulator Setpoint (Counter Timer mode)	1	1,000,000
Feed Percentage (Bleed then Feed mode)	0%	1000%
Feed Lockout Time Limit (Bleed & Feed, Bleed then Feed modes)	0 seconds	86,400 seconds
Prebleed To Conductivity (Biocide mode)	1 (0 = no prebleed)	High end of sensor range
Prebleed Time (Biocide mode)	0 seconds	86,400 seconds
Bleed Lockout (Biocide mode)	0 seconds	86,400 seconds
Event duration (Biocide, Timer modes)	0	30,000
Proportional band (Time/Pulse Proportional mode, Intermittent Sampling)	Low end of sensor range	High end of sensor range
Sample period (Time Proportional mode)	0 seconds	3600 seconds
Sample Time (Intermittent Sampling mode)	0 seconds	3600 seconds
Hold Time (Probe Wash, Intermittent Sampling modes)	0 seconds	3600 seconds
Maximum Blowdown (Intermittent Sampling mode)	0 seconds	3600 seconds
Wait Time (Intermittent Sampling mode)	0 seconds	86,400 seconds
Max Rate (Pulse Proportional, Pulse PID, Flow Prop modes)	10 pulses/minute	2400 pulses/minute
Minimum Output (Pulse Proportional, Pulse PID modes)	0%	100%
Maximum Output (Pulse Proportional, Pulse PID modes)	0%	100%
Gain (Pulse PID Standard mode)	0.001	1000.000
Integral Time (Pulse PID Standard mode)	0.001 seconds	1000.000 seconds
Derivative Time (Pulse PID Standard mode)us	0 seconds	1000.000 seconds
Proportional Gain (Pulse PID Parallel mode)	0.001	1000.000
Integral Gain (Pulse PID Parallel mode)	0.001 /second	1000.000 /second
Derivative Gain (Pulse PID Parallel mode)	0 seconds	1000.000 seconds
Input Minimum (Pulse PID modes)	Low end of sensor range	High end of sensor range
Input Maximum (Pulse PID modes)	Low end of sensor range	High end of sensor range
Wear Cycle Time (Lag mode)	10 seconds	23:59:59 HH:MM:SS
Delay Time (Lag mode)	0 seconds	23:59:59 HH:MM:SS
Target (Target PPM, PPM Volume modes)	0 ppm	1,000,000 ppm
Pump Capacity (Target PPM, PPM Volume modes)	0 gal/hour or l/hour	10,000 gal/hour or l/hour
Pump Setting (Target PPM, PPM Volume modes)	0%	100%
Specific Gravity (Target PPM, PPM Volume modes)	0 g/ml	9.999 g/ml
Blend Volume (Volumetric Blend mode)	1	1,000,000
Low Cycles Limit (Target PPM, PPM Volume mode)	0 cycles of concentration	100 cycles of concentration

Bleed Volume (Flow Meter Ratio mode)	1	1,000,000
Pump Capacity (Mass Balance mode)	0 gal/hour or l/hour	10,000 gal/hour or l/hour
Pump Setting (Mass Balance mode)	0%	100%
Specific Gravity (Mass Balance mode)	0 g/ml	9.999 g/ml
Target (Mass Balance mode)	0 ppm	1,000,000 ppm
<b>Analog (4-20 mA) Output Settings</b>	<b>Low Limit</b>	<b>High Limit</b>
4 mA Value (Retransmit mode)	Low end of sensor range	High end of sensor range
20 mA Value (Retransmit mode)	Low end of sensor range	High end of sensor range
Hand Output	0%	100%
Set Point (Proportional, PID modes)	Low end of sensor range	High end of sensor range
Proportional Band (Proportional mode)	Low end of sensor range	High end of sensor range
Minimum Output (Proportional, PID, Disturbance modes)	0%	100%
Maximum Output (Proportional, PID, Disturbance modes)	0%	100%
Off Mode Output (Proportional, PID, Mass Balance, Disturbance modes)	0 mA	21 mA
Error Output (not in Manual mode)	0 mA	21 mA
Hand Time Limit (not in Retransmit mode)	1 second	86,400 seconds (0 = unlimited)
Output Time Limit (Proportional, PID, Disturbance modes)	1 second	86,400 seconds (0 = unlimited)
Gain (PID, Standard mode)	0.001	1000.000
Integral Time (PID Standard mode)	0.001 seconds	1000.000 seconds
Derivative Time (PID Standard mode)	0 seconds	1000.000 seconds
Proportional Gain (PID Parallel mode)	0.001	1000.000
Integral Gain (PID Parallel mode)	0.001 /second	1000.000 /second
Derivative Gain (PID Parallel mode)	0 seconds	1000.000 seconds
Input Minimum (PID modes)	Low end of sensor range	High end of sensor range
Input Maximum (PID modes)	Low end of sensor range	High end of sensor range
Pump Capacity (Mass Balance mode)	0 gal/hour or l/hour	10,000 gal/hour or l/hour
Pump Setting (Mass Balance mode)	0%	100%
Specific Gravity (Mass Balance mode)	0 g/ml	9.999 g/ml
Target (Mass Balance mode)	0 ppm	1,000,000 pm
Low Cycles Limit (Mass Balance mode)	0 cycles of concentration	100 cycles of concentration
<b>Configuration settings</b>	<b>Low Limit</b>	<b>High Limit</b>
Local Password	0000	9999
Log in Timeout	10 minutes	1440 minutes
Fluent update period	1 minute	1440 minutes
Fluent reply timeout	10 seconds	60 seconds
Alarm Delay	0:00 minutes	59:59 minutes
SMTP Port	0	65535
TCP Timeout	1 second	240 seconds
Auto Dim Time	0 seconds	23:59:59 HH:MM:SS
Device ID (BACnet)	1	4194302
Data Port (Modbus, BACnet)	1	65535
Ad-Hoc Time Limit	1 min.	1440 min.
<b>Graph settings</b>	<b>Low Limit</b>	<b>High Limit</b>
Low axis limit	Low end of sensor range	High end of sensor range
High axis limit	Low end of sensor range	High end of sensor range

## 3.0 UNPACKING & INSTALLATION

---

### 3.1 Unpacking the unit

Inspect the contents of the carton. Please notify the carrier immediately if there are any signs of damage to the controller or its parts. Contact your distributor if any of the parts are missing. The carton should contain an OnGuard™ P900 series controller and an instruction manual. Any options or accessories will be incorporated as ordered.

### 3.2 Mounting the electronic enclosure

The controller is supplied with mounting holes on the enclosure. It should be wall mounted with the display at eye level, on a vibration-free surface, utilizing all four mounting holes for maximum stability. Do not install the enclosure in a location where it will be exposed to direct sunlight. Use M6 (1/4" diameter) fasteners that are appropriate for the substrate material of the wall. The enclosure is NEMA 4X (IP65) rated. The maximum operating ambient temperature is 122°F (50°C); this should be considered if installation is in a high temperature location. The enclosure requires the following clearances:

Top:	2" (50 mm)
Left:	10" (254 mm)
Right:	4" (102 mm)
Bottom:	7" (178 mm)

### 3.3 Sensor Installation

Refer to the specific instructions supplied with the sensor being used, for detailed installation instructions.

#### General Guidelines

Locate the sensors where an active sample of water is available and where the sensors can easily be removed for cleaning. Position the sensor such that air bubbles will not be trapped within the sensing area. Position the sensor where sediment or oil will not accumulate within the sensing area.

#### In-Line Sensor Mounting

In-line mounted sensors must be situated so that the tee is always full and the sensors are never subjected to a drop in water level resulting in dryness. Refer to Figure 2 for typical installation.

Tap off the discharge side of the recirculation pump to provide a minimum flow of 1 gallon per minute through the flow switch manifold. The sample must flow into the bottom of the manifold in order to close the flow switch, and return to a point of lower pressure in order to ensure flow. Install an isolation valve on both sides of the manifold to stop flow for sensor maintenance.

**IMPORTANT:** To avoid cracking the female pipe threads on the supplied plumbing parts, use no more than 3 wraps of Teflon tape and thread in the pipe FINGER tight plus 1/2 turn! Do not use pipe dope to seal the threads of the flow switch because the clear plastic will crack!

#### Submersion Sensor Mounting

If the sensors are to be submersed in the process, mount them firmly to the tank, and protect the cable with plastic pipe, sealed at the top with a cable gland, to prevent premature failure. Place the sensors in an area of good solution movement.

Sensors should be located such that they respond rapidly to a well-mixed sample of the process water and the treatment chemicals. If they are too close to the chemical injection point, they will see spikes in concentration and cycle on and off too frequently. If they are too far away from the chemical injection point, they will respond too slowly to the concentration changes, and you will overshoot the set point.

The **contacting conductivity sensor** should be placed as close to the controller as possible, to a maximum distance of 250 ft. (76 m). Less than 25 ft. (8 m) is recommended. The cable must be shielded from background electrical noise. Always route low voltage (sensor) signals with at least a 6" (15 cm) separation from AC voltage wiring.

The **electrodeless conductivity sensor** should be placed as close to the controller as possible, to a maximum distance of 120 ft. (37 m). Less than 20 ft. (6 m) is recommended. The cable must be shielded from background

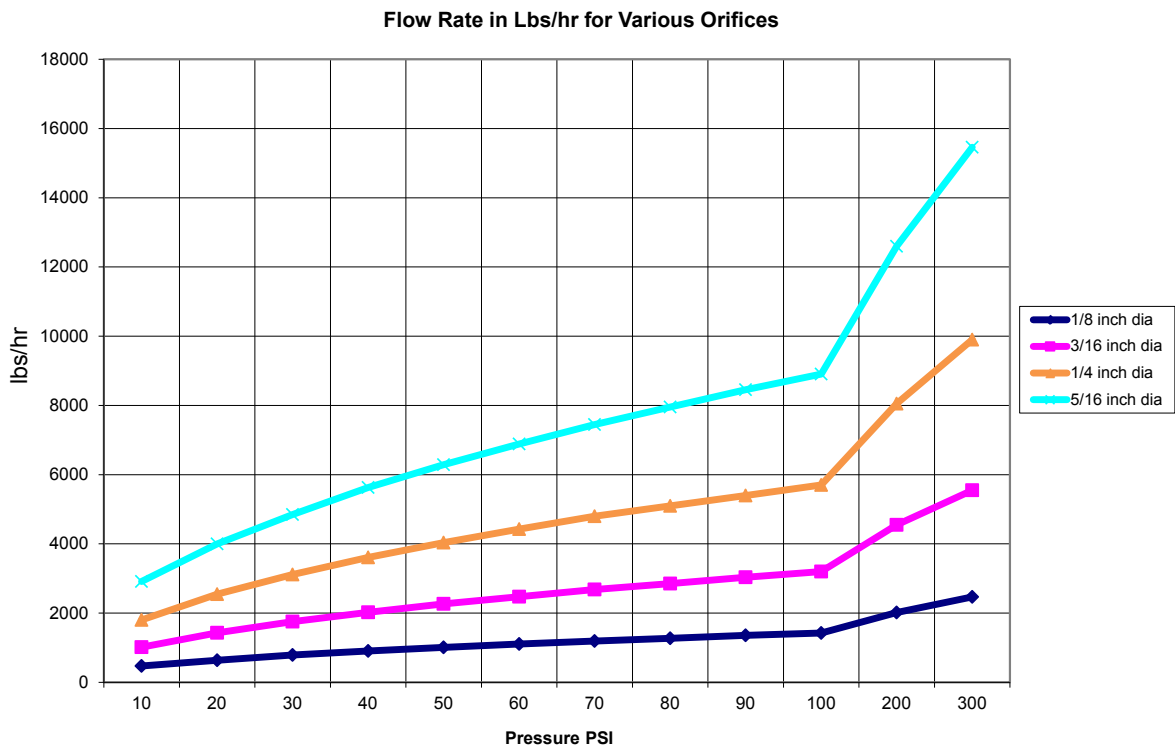


electrical noise. Always route low voltage (sensor) signals with at least a 6” (15 cm) separation from AC voltage wiring. These sensors are affected by the geometry and conductivity of their surroundings, so either maintain 6 inches (15 cm) of sample around the sensor or ensure that any nearby conductive or non-conductive items are consistently positioned. Do not install the sensor in the path of any electrical current that may be flowing in the solution, as this will shift the conductivity reading.

The **amplified pH/ORP/ISE electrode** should be placed as close to the controller as possible, to a maximum distance of 1000 feet (305 m) from the controller. A junction box and shielded cable are available to extend the standard 20 foot (6 m) length. pH and ORP electrodes must be installed such that the measuring surfaces will always remain wet. A U-trap provided in the manifold design should achieve this, even if the sample flow stops. These electrodes also must be installed with the measuring surfaces pointing down; that is 5 degrees above the horizontal, at a minimum. The flow velocity past the sensor must be less than 10 ft./sec. (3 m/sec.)

The **disinfection sensor** should be placed as close to the controller as possible, to a maximum distance of 100 feet (30 m) from the controller. A junction box and shielded cable are available to extend the standard 20 foot (6 m) length. The sensor should be mounted such that the measuring surfaces will always stay wet. If the membrane dries out, it will respond slowly to changing disinfectant values for 24 hours, and if dried out repeatedly, will fail prematurely. The flow cell should be placed on the discharge side of a circulation pump or downhill from a gravity feed. Flow into the cell must come from the bottom side that has the 3/4” x 1/4” NPT reducing bushing installed. The reducing bushing provides the flow velocity required for accurate readings and must not be removed! A “U” trap should be installed so that if the flow stops, the sensor is still immersed in the water. The outlet of the flow cell must be plumbed to open atmosphere unless the system pressure is at or below 1 atmosphere. If the flow through the line cannot be stopped to allow for cleaning and calibration of the sensor, then it should be placed in a by-pass line with isolation valves to allow for sensor removal. Install the sensor vertically, with the measuring surface pointing down, at least 5 degrees above horizontal. Flow rate regulation must be done upstream from the sensor, because any flow restriction downstream can increase the pressure above atmospheric and damage the membrane cap!

The **corrosion sensor** should be placed as close to the controller as possible, to a maximum distance of 100 feet (30 m) from the controller. A junction box and shielded cable (p/n 100084) are available to extend the standard 6 foot (3 m) or 20 foot (6 m) length. The sensor should not be installed unless the o-rings/electrodes that match the metallurgy to be examined are attached to the steel threaded rods. Standard corrosion electrodes are 5 cm<sup>2</sup> surface area. Do not touch the metal electrodes; they should be clean and free of any scratches, oils or contamination to accurately measure the corrosion. The sensor should be mounted horizontally, such that the measuring



surfaces will always stay completely wet. The sensor should ideally be installed in the side branch of a 1" or ¾" tee, with the flow entering the tee through the top branch and flowing away from the base of the sensor, towards the tips of the electrodes. A constant flow rate is required, at a minimum of 1.5 gpm (5.7 lpm) with an ideal flow rate of 5 gpm (19 lpm). If more than one metal is to be used, the most noble metal should be first.

### **Important Boiler Sensor Installation Notes: (refer to typical installation drawing)**

1. Make sure the minimum water level in the boiler is at least 4-6 inches above the skimmer blowdown line. If the skimmer line is closer to the surface, it is likely that steam will be drawn into the line instead of boiler water. The skimmer line must also be installed above the highest tube.
2. Maintain a ¾ inch minimum pipe ID with no flow restrictions from the tap for the boiler skimmer blowdown line to the electrode. If the ID is reduced below ¾ inch, then flashing will occur beyond that point and the conductivity reading will be low and erratic. Minimize the usage of tees, valves, elbows or unions between the boiler and the electrode.
3. A manual shut off valve should be installed so that the electrode can be removed and cleaned. This valve must be a full port valve in order to avoid a flow restriction.
4. Keep the distance between the tap for the boiler skimmer line to the electrode as short as possible, to a maximum of 10 feet.
5. Mount the electrode in the side branch of a cross in a horizontal run of pipe. This will minimize entrapment of steam around the electrode and will allow any solids to pass through.
6. There **MUST** be a flow restriction after the electrode and/or control valve in order to provide back pressure. This flow restriction will be either a flow control valve or an orifice union. The amount of the flow restriction will affect the blowdown rate as well, and should be sized accordingly.
7. Install the motorized ball valve or solenoid valve per the manufacturer's instructions.

For best results, align the hole in the conductivity electrode such that the direction of water flow is through the hole.

### **Guide to Sizing Blowdown Valves and Orifice Plates**

#### **1. Determine the Rate of Steam Production in Pounds per Hour:**

Either read off the boiler name plate (water-tube boilers) or Calculate from horsepower rating (fire-tube boilers):  $HP \times 34.5 = \text{lbs/hr}$ . Example:  $100 \text{ HP} = 3450 \text{ lbs/hr}$ .

#### **2. Determine the Concentration Ratio (BASED ON FEEDWATER)**

A water treatment chemical specialist should determine the desired number of cycles of concentration. This is the ratio of TDS in the boiler water to TDS in the feedwater. Note that feedwater means the water that is fed to the boiler from the deaerator and includes makeup water plus condensate return. Example: 10 cycles of concentration has been recommended

#### **3. Determine the Required Blowdown Rate in Pounds Per Hour**

$\text{Blowdown Rate} = \text{Steam Production} / (\text{Concentration Ratio} - 1)$  Example:  $3450 / (10 - 1) = 383.33 \text{ lbs./hr}$

#### **4. Determine if Continuous or Intermittent Sampling is Required**

Use intermittent sampling when the boiler operation or loading is intermittent, or on boilers where the required blowdown rate is less than 25% of the smallest available flow control valve or less than the flow through the smallest orifice. See the graphs on the next page.

Use continuous sampling when the boiler is operating 24 hours per day and the required blowdown rate is more than 25% of the smallest applicable flow control valve or orifice. See the graphs on the next page.

Use of a flow control valve will give you the best control of the process, since the flow rate can be easily adjusted. The dial on the valve also gives you a visual indication if the flow rate has been changed. If the valve clogs, it can be opened to clear the obstruction, and closed to the previous position.

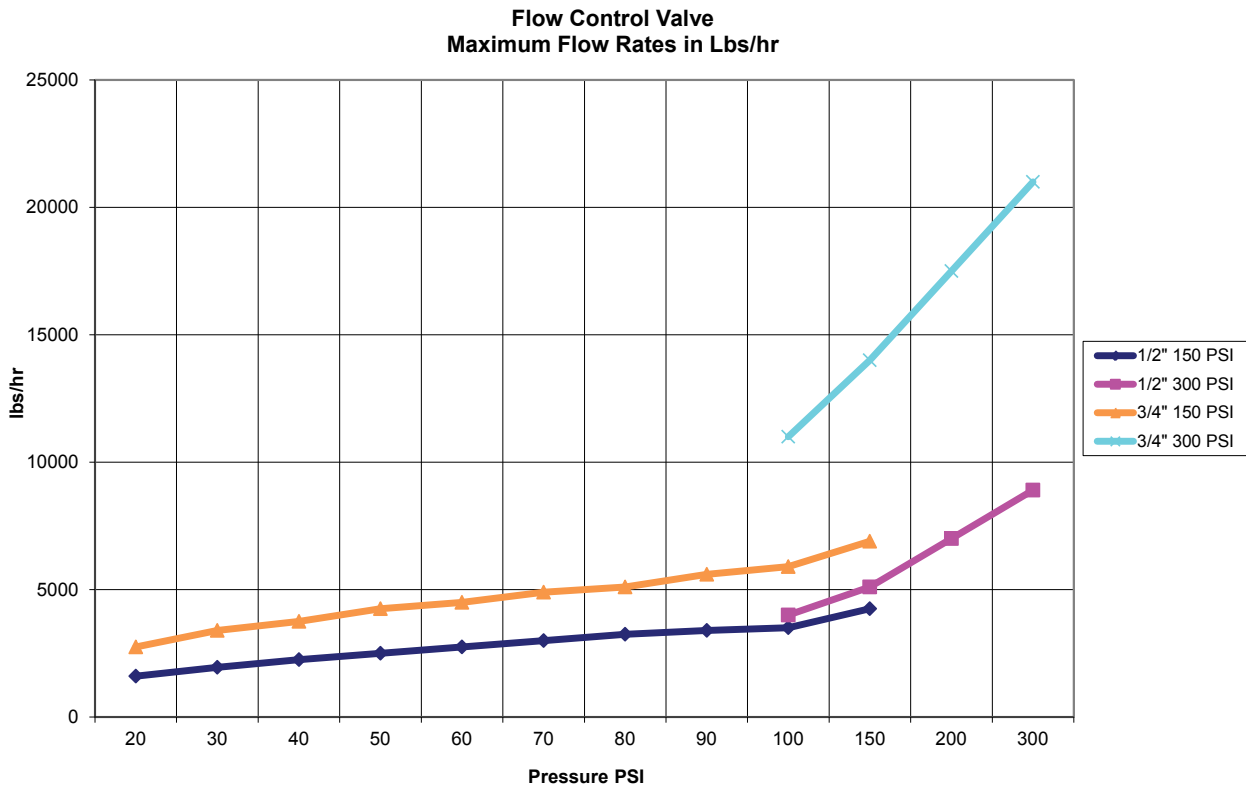
If an orifice plate is used, you must install a valve downstream from the orifice in order to fine tune the flow rate and provide additional back pressure in many applications.

Example: An 80 psi boiler has a Required Blowdown Rate of 383.33 lbs./hr. The maximum flow rate of the

smallest flow control valve is 3250 lbs./hr.  $3250 \times 0.25 = 812.5$  which is too high for continuous sampling. Using an orifice, the flow rate through the smallest diameter plate is 1275 lbs./hr. This is too high for continuous sampling.

**5. Determine the Orifice or Flow Control Valve Size for this Blowdown Rate**

Use the following graphs to select a flow control device:



**3.4 Icon Definitions**

Symbol	Publication	Description
	IEC 417, No.5019	Protective Conductor Terminal
	IEC 417, No. 5007	On (Supply)
O	IEC 417, No. 5008	Off (Supply)
	ISO 3864, No. B.3.6	Caution, risk of electric shock
	ISO 3864, No. B.3.1	Caution

### 3.5 Electrical installation

The various standard wiring options are shown in figure 1, below. Your controller will arrive from the factory prewired or ready for hardwiring. Depending on your configuration of controller options, you may be required to hardwire some or all of the input/output devices. Refer to figures 6 through 18 for circuit board layout and wiring.

Note: when wiring the optional flow meter contactor input, the 4-20 mA outputs or a remote flow switch, it is advisable to use stranded, twisted, shielded pair wire between 22-26 AWG. Shield should be terminated at the controller at the most convenient shield terminal.



## CAUTION



1.	There are live circuits inside the controller even when the power switch on the front panel is in the OFF position! The front panel must never be opened before power to the controller is REMOVED! If your controller is prewired, it is supplied with an 8 foot, 14 AWG power cord with NEMA 5-15P USA style plug. A tool (#2 Phillips driver) is required to open the front panel.
2.	When mounting the controller, make sure there is clear access to the disconnecting device!
3.	The electrical installation of the controller must be done by trained personnel only and conform to all applicable National, State and Local codes!
4.	Proper grounding of this product is required. Any attempt to bypass the grounding will compromise the safety of persons and property.
5.	Operating this product in a manner not specified by Walchem may impair the protection provided by the equipment.

Figure 1 Conduit Wiring

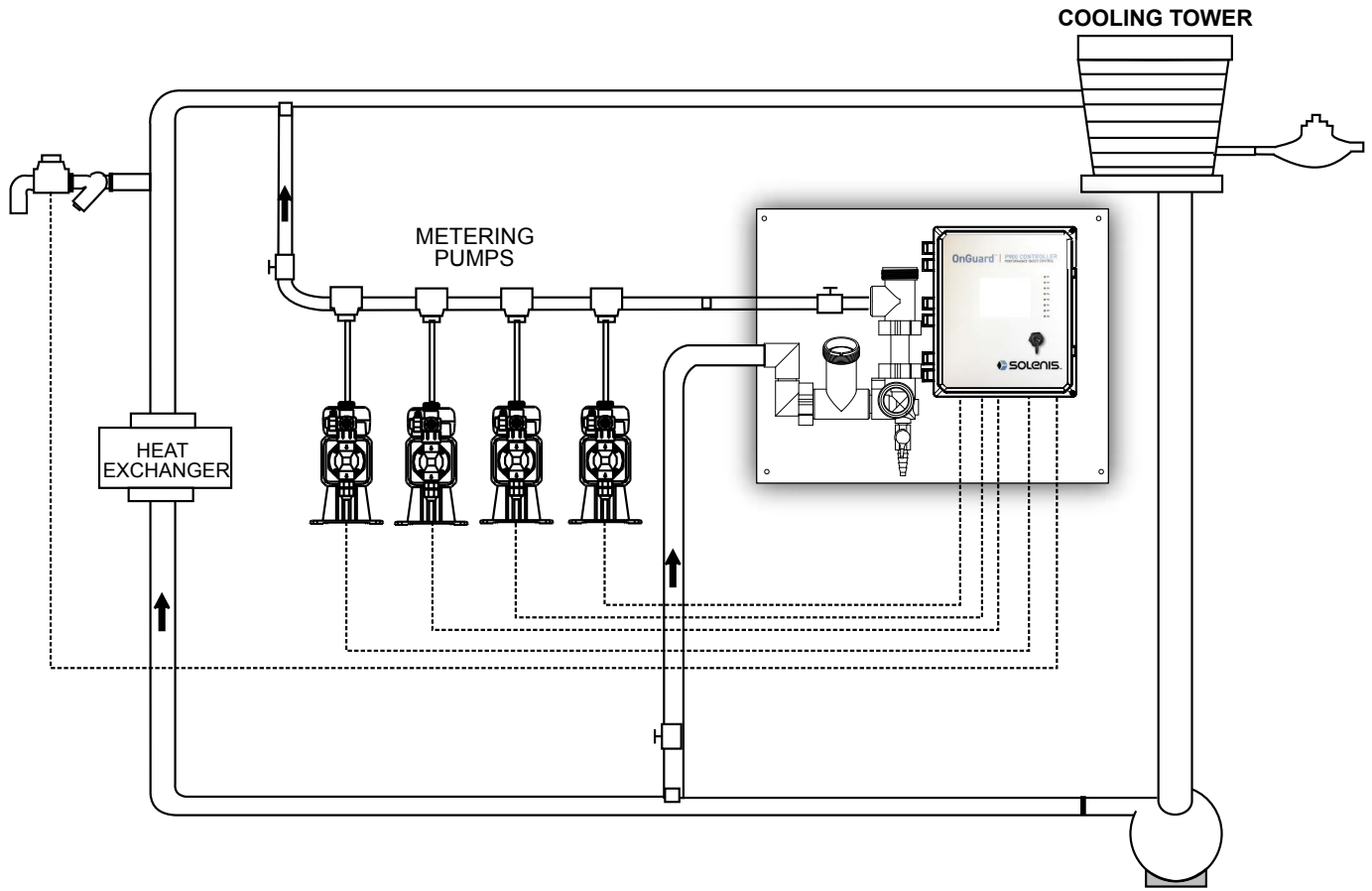
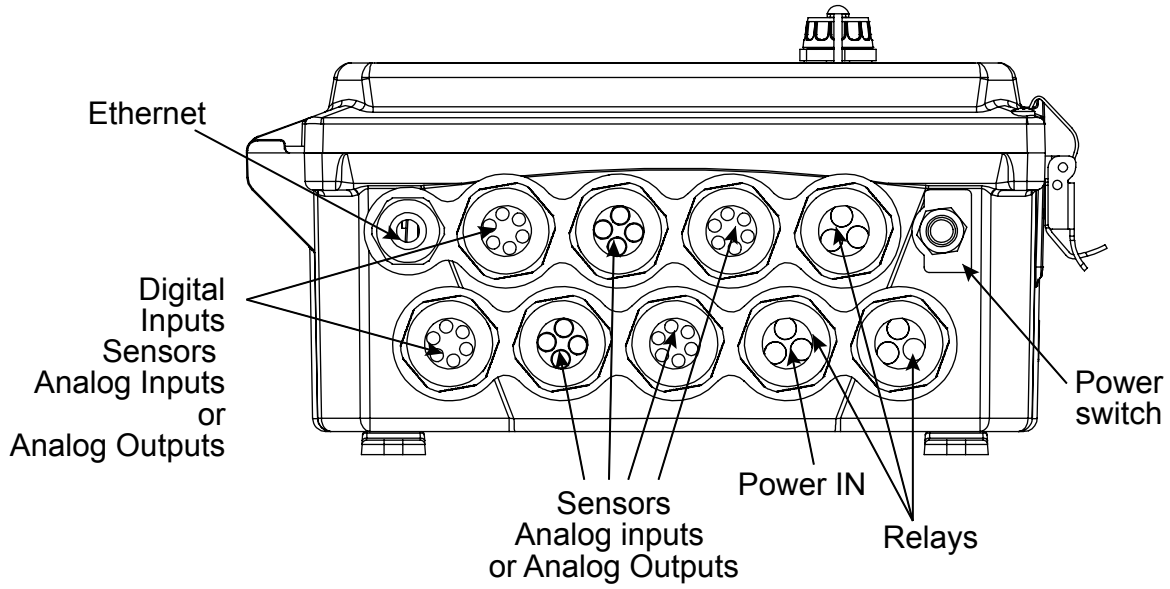
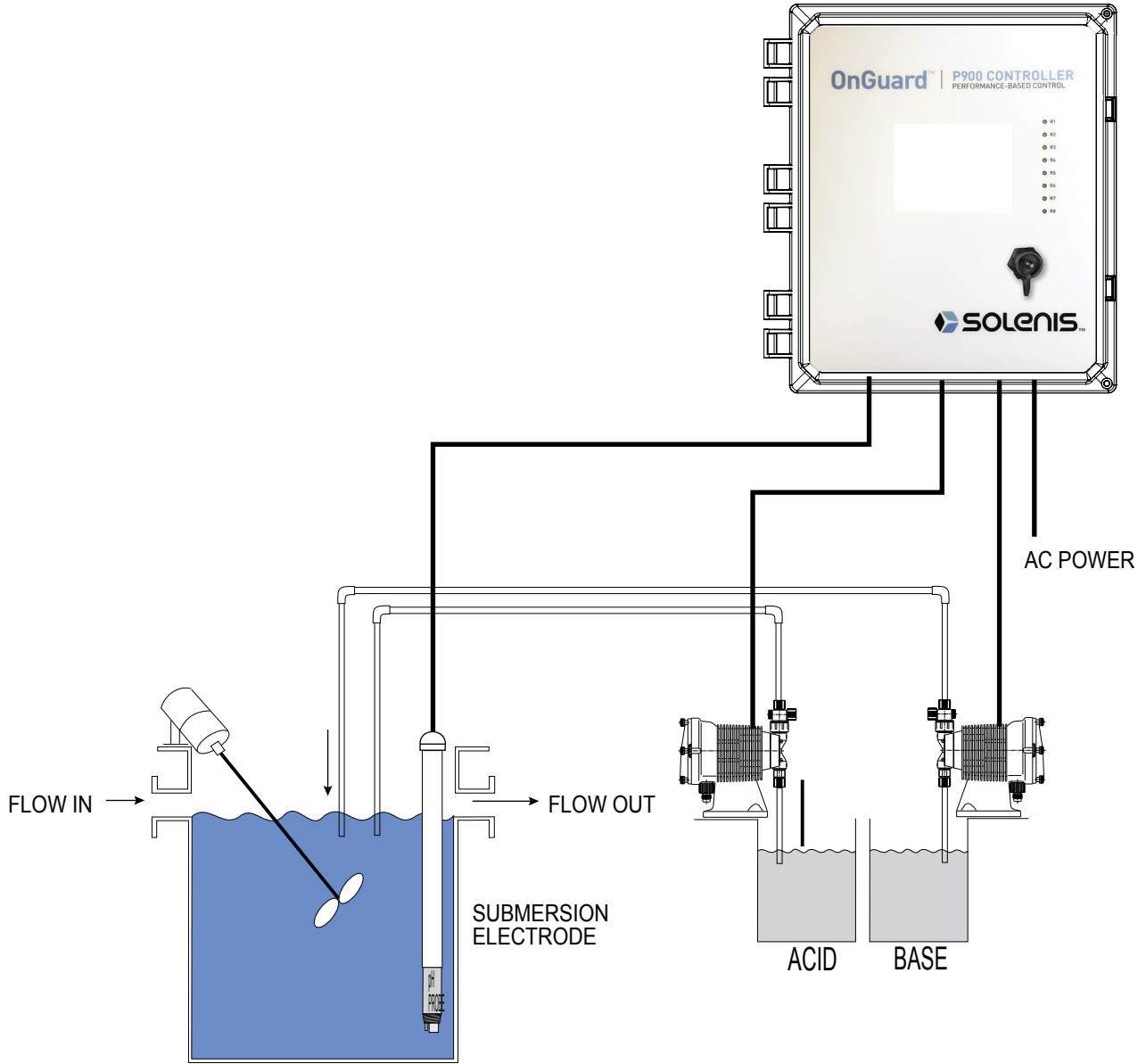
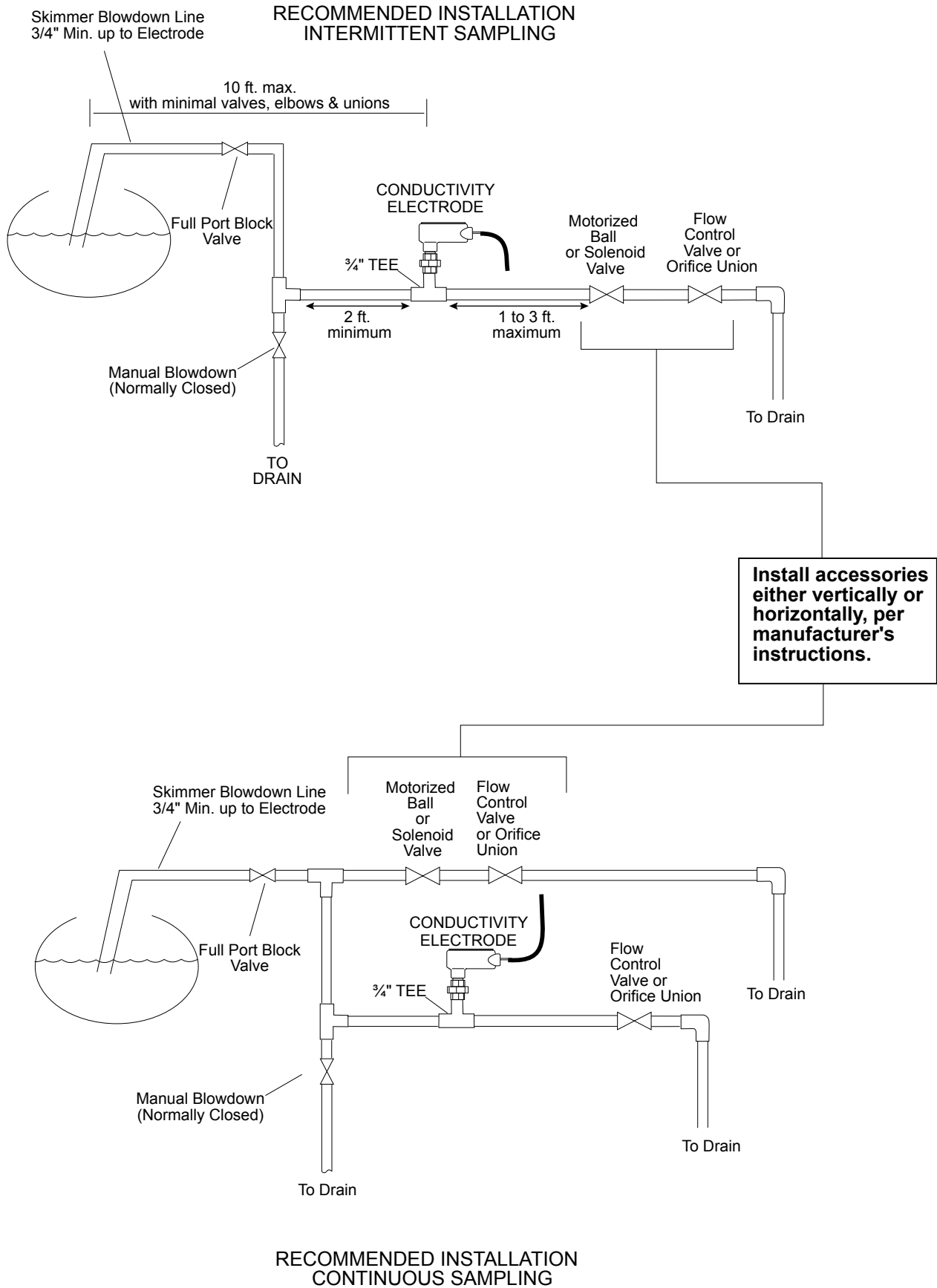


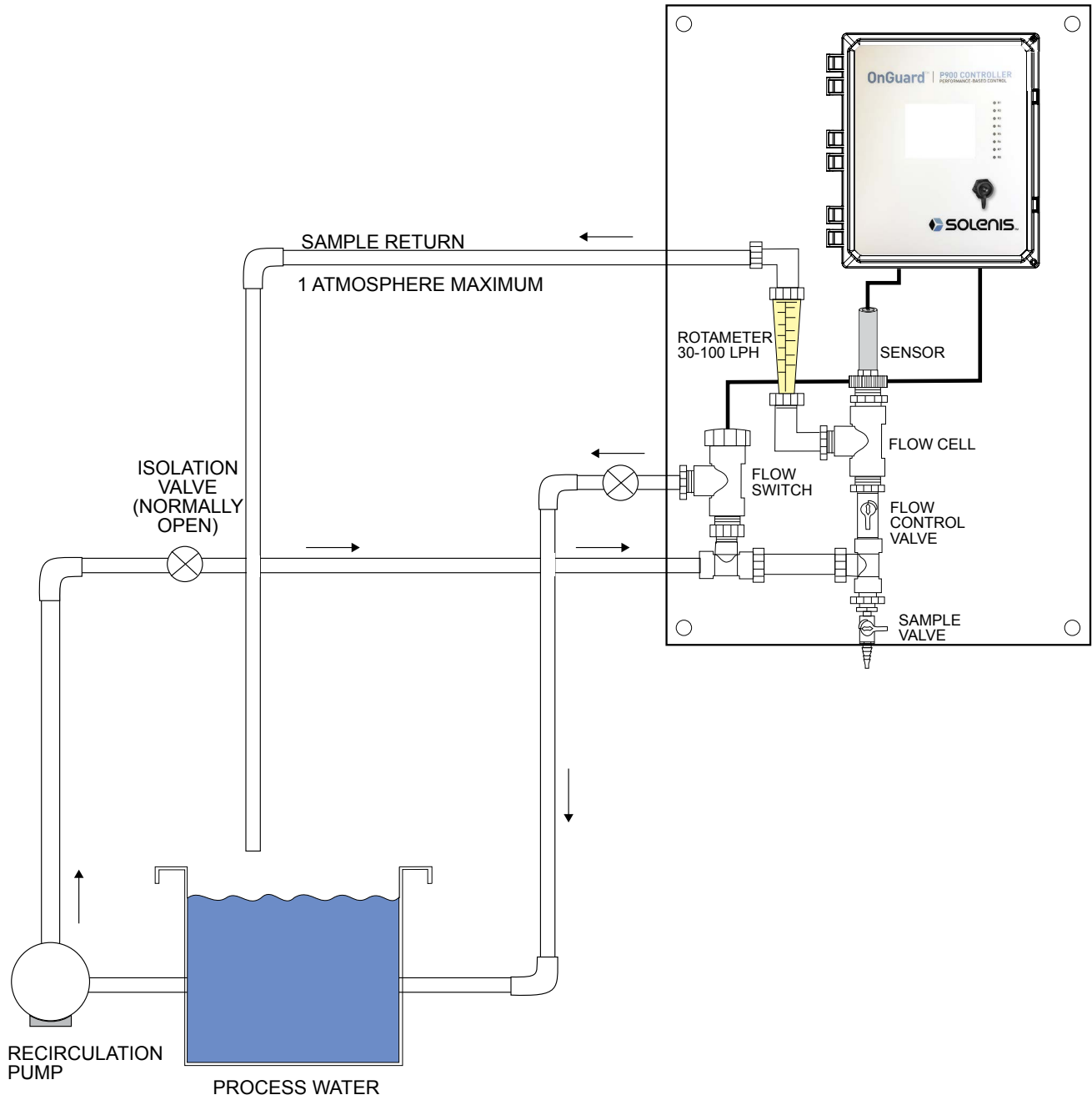
Figure 2 Typical Installation – Cooling Tower



**Figure 3 Typical Installation – Submersion**

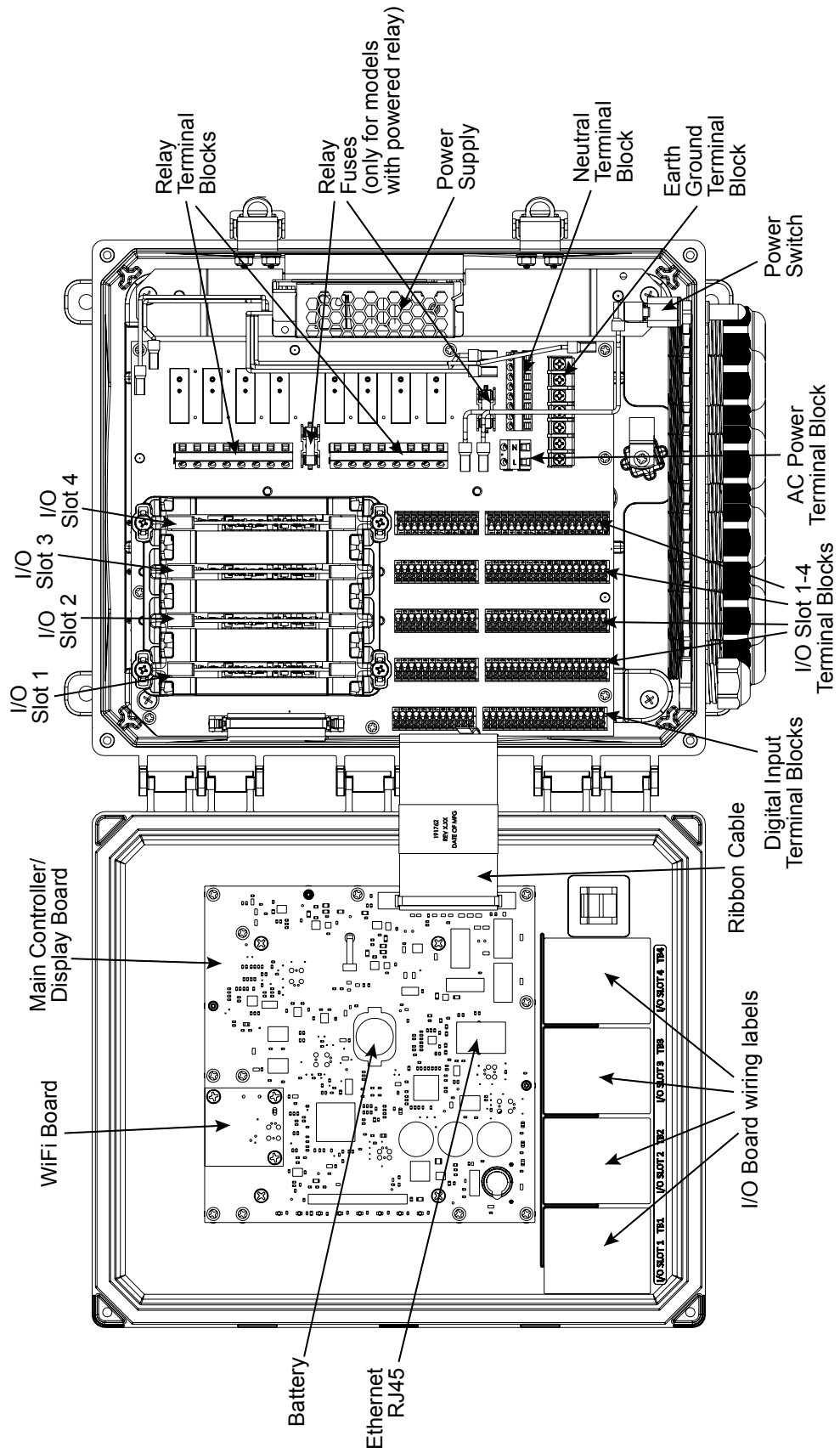


**Figure 4 Typical Installation – Boiler**



**Figure 5 Typical Installation – Disinfection Sensor**





**Figure 6 Parts Identification**

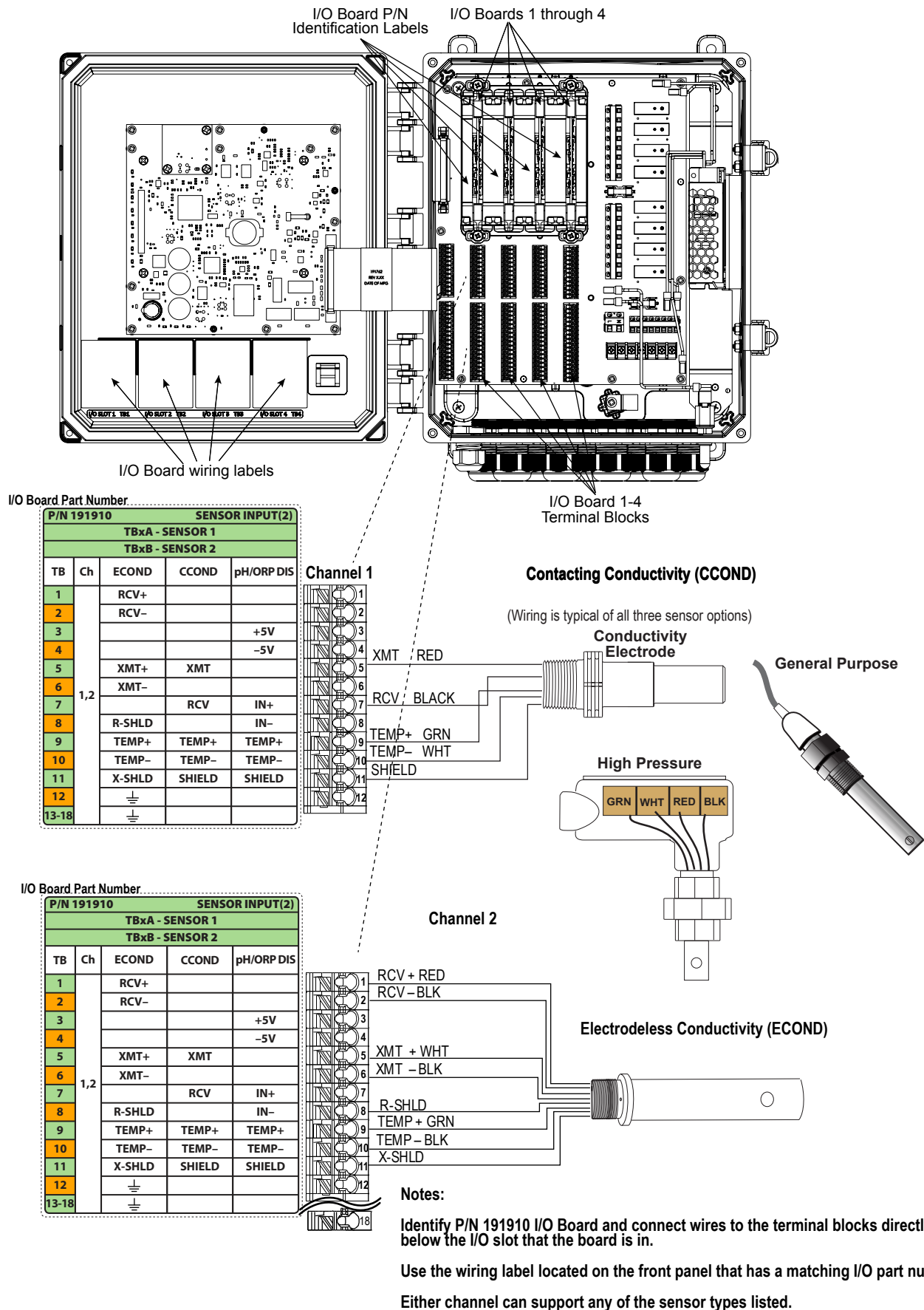
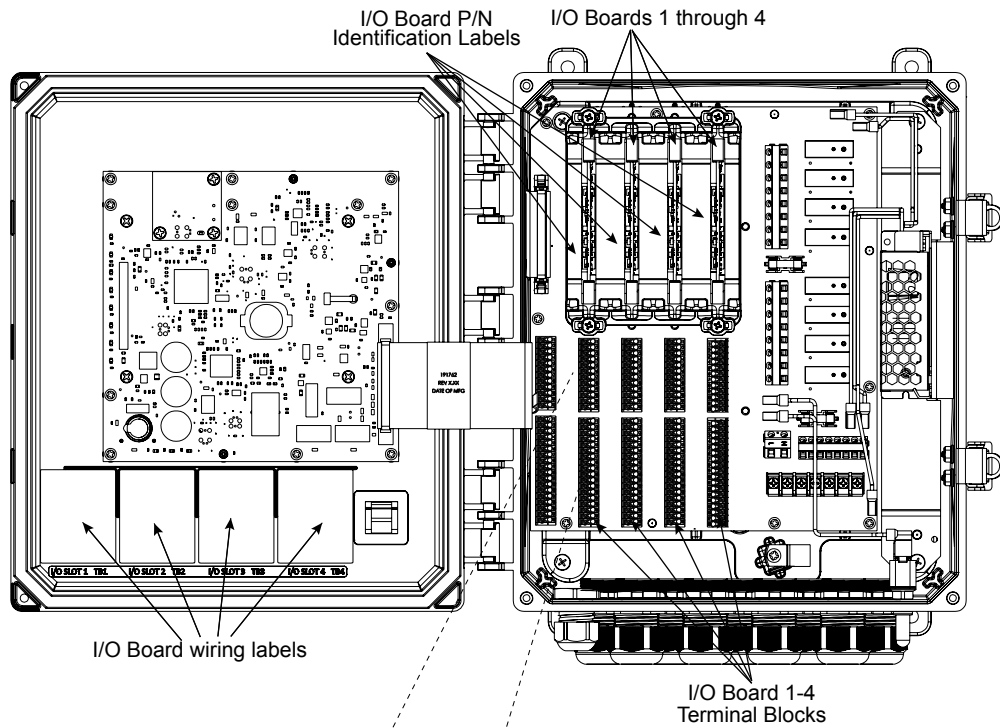
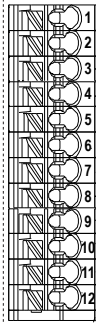


Figure 7 Part Number 191910 Dual Sensor Board wiring - Conductivity



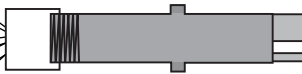
I/O Board Part Number...

P/N 191910		SENSOR INPUT(2)			
		TBxA - SENSOR 1		TBxB - SENSOR 2	
TB	Ch	ECOND	CCOND	pH/ORP DIS	
1	1,2	RCV+			
2		RCV-			
3					+5V
4					-5V
5		XMT+	XMT		
6		XMT-			
7			RCV		IN+
8		R-SHLD			IN-
9		TEMP+	TEMP+	TEMP+	
10		TEMP-	TEMP-	TEMP-	
11		X-SHLD	SHIELD	SHIELD	
12					
13-18					



- 1 +5V BLUE/WHITE
- 2 -5V WHITE/BLUE
- 3
- 4
- 5
- 6
- 7 IN+ ORANGE/WHITE
- 8 IN- WHITE/ORANGE
- 9 TEMP+ GREEN/WHITE
- 10 TEMP- WHITE/GREEN
- 11 SHIELD
- 12

pH/ORP/ISE Sensor with  
Optional Temperature Compensation



**Notes:**

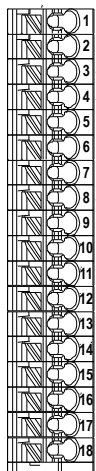
Identify P/N 191910 I/O Board and connect wires to the terminal blocks directly below the I/O slot that the board is in.

Use the wiring label located on the front panel that has a matching I/O part number.

Either channel can support any of the sensor types listed.

I/O Board Part Number...

P/N 191910		SENSOR INPUT(2)			
		TBxA - SENSOR 1		TBxB - SENSOR 2	
TB	Ch	ECOND	CCOND	pH/ORP DIS	
1	1,2	RCV+			
2		RCV-			
3					+5V
4					-5V
5		XMT+	XMT		
6		XMT-			
7			RCV		IN+
8		R-SHLD			IN-
9		TEMP+	TEMP+	TEMP+	
10		TEMP-	TEMP-	TEMP-	
11		X-SHLD	SHIELD	SHIELD	
12					
13-18					

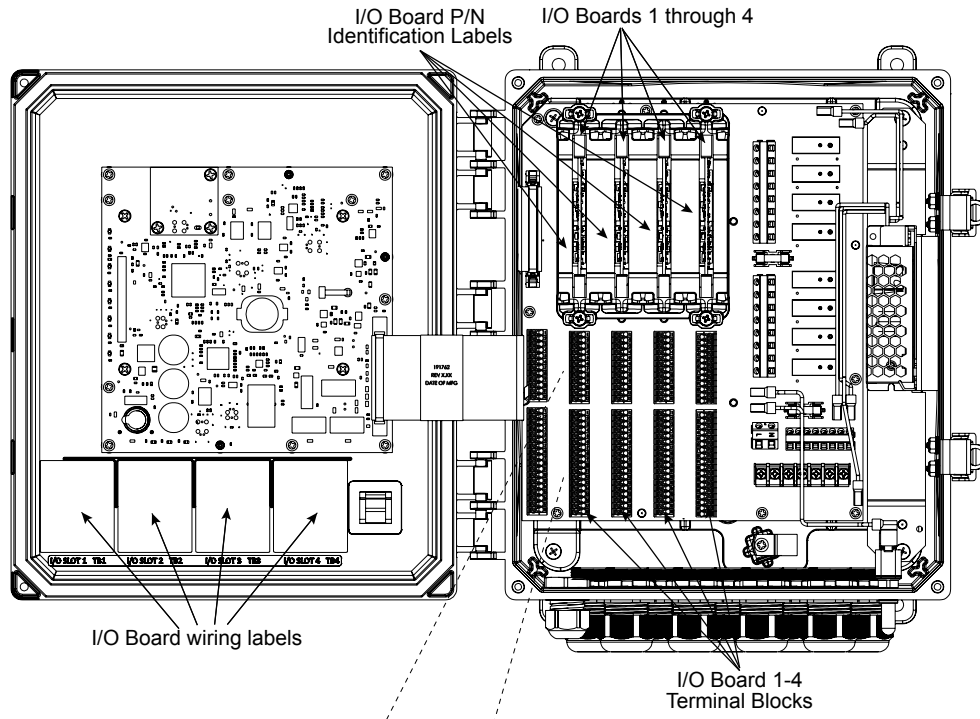


- 1 +5V BLUE/WHITE
- 2 -5V WHITE/BLUE
- 3
- 4
- 5
- 6
- 7 IN+ ORANGE/WHITE
- 8 IN- WHITE/ORANGE
- 9
- 10
- 11 SHIELD
- 12
- 13
- 14
- 15
- 16
- 17
- 18

pH/ORP/ISE Sensor without  
Optional Temperature Compensation

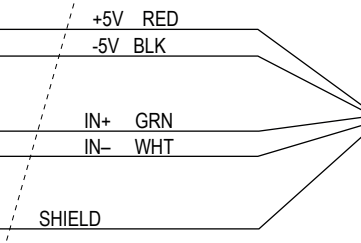
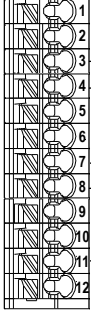


**Figure 8 Part Number 191910 Dual Sensor Board Wiring - pH/ORP/ISE**

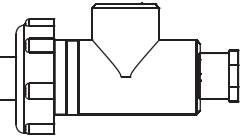


I/O Board Part Number

P/N 191910		SENSOR INPUT(2)			
		TBxA - SENSOR 1			
		TBxB - SENSOR 2			
TB	Ch	ECOND	CCOND	pH/ORP DIS	
1	1,2	RCV+			
2		RCV-			
3				+5V	
4				-5V	
5		XMT+	XMT		
6		XMT-			
7			RCV	IN+	
8		R-SHLD		IN-	
9		TEMP+	TEMP+	TEMP+	
10		TEMP-	TEMP-	TEMP-	
11		X-SHLD	SHIELD	SHIELD	
12			⏏		
13-18		⏏			



Disinfection Sensor



Notes:

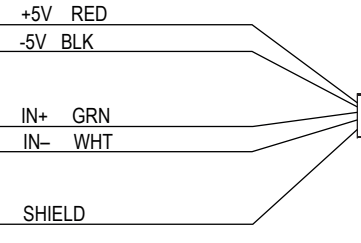
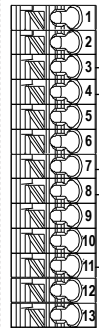
Identify P/N 191910 I/O Board and connect wires to the terminal blocks directly below the I/O slot that the board is in.

Use the wiring label located on the front panel that has a matching I/O part number.

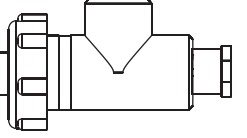
Either channel can support any of the sensor types listed.

I/O Board Part Number

P/N 191910		SENSOR INPUT(2)			
		TBxA - SENSOR 1			
		TBxB - SENSOR 2			
TB	Ch	ECOND	CCOND	pH/ORP DIS	
1	1,2	RCV+			
2		RCV-			
3				+5V	
4				-5V	
5		XMT+	XMT		
6		XMT-			
7			RCV	IN+	
8		R-SHLD		IN-	
9		TEMP+	TEMP+	TEMP+	
10		TEMP-	TEMP-	TEMP-	
11		X-SHLD	SHIELD	SHIELD	
12			⏏		
13-18		⏏			



Disinfection Sensor



Shields

Figure 9 Part Number 191910 Dual Sensor Board Wiring - Disinfection

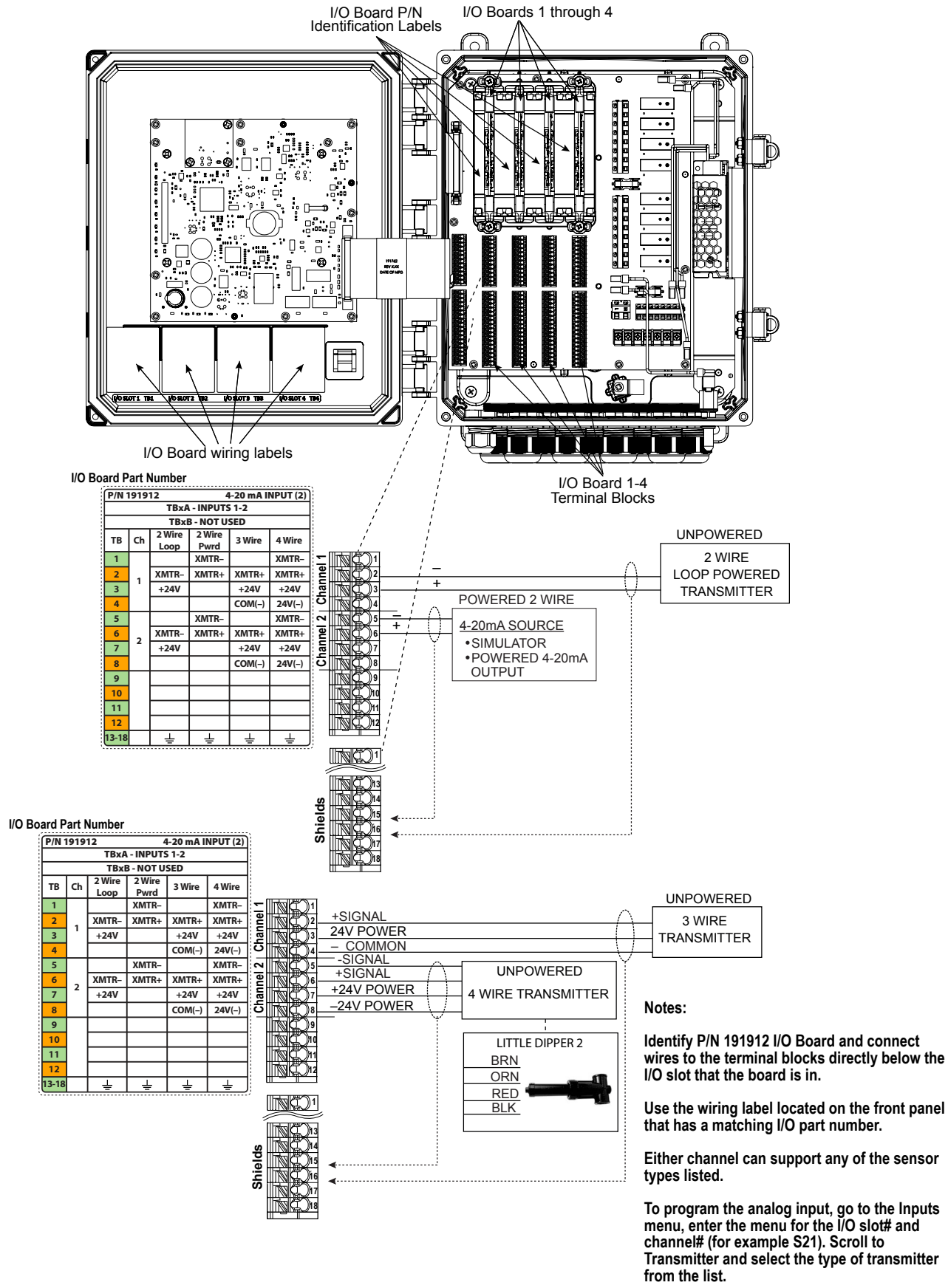
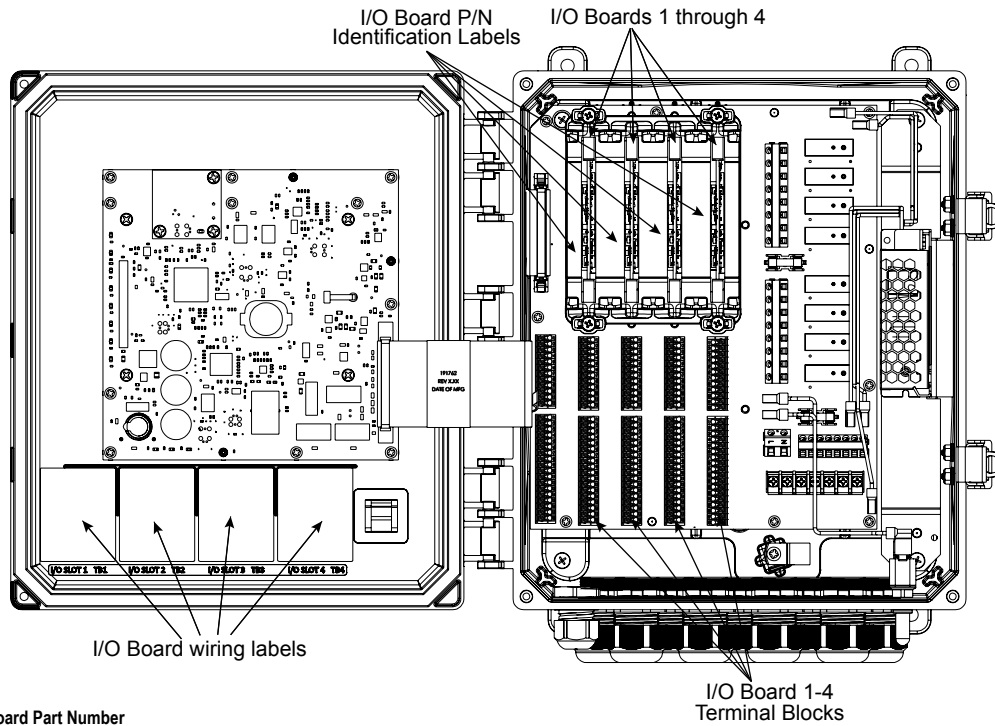
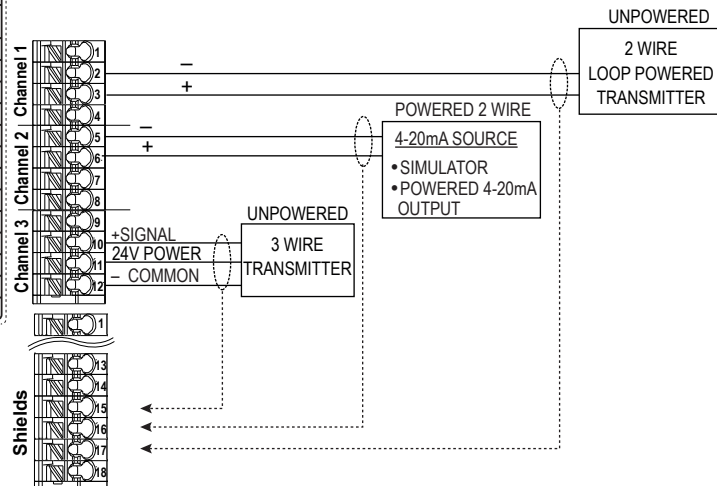


Figure 10 Part Number 191912 Dual Analog (4-20mA) Sensor Input Board Wiring



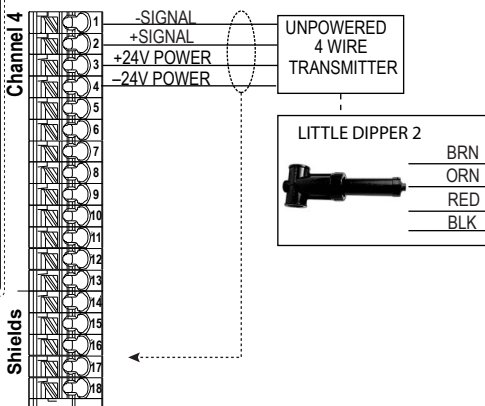
**I/O Board Part Number**

P/N 191913		4-20 mA INPUT (4)			
		TBxA - INPUTS 1-3		TBxB - INPUT 4	
TB	Ch	2 Wire Loop	2 Wire Pwr	3 Wire	4 Wire
1	1,4		XMTR-		XMTR-
2		XMTR-	XMTR+	XMTR+	XMTR+
3		+24V		+24V	+24V
4				COM(-)	24V(-)
5	2		XMTR-		XMTR-
6		XMTR-	XMTR+	XMTR+	XMTR+
7		+24V		+24V	+24V
8				COM(-)	24V(-)
9	3		XMTR-		XMTR-
10		XMTR-	XMTR+	XMTR+	XMTR+
11		+24V		+24V	+24V
12				COM(-)	24V(-)
13-18					



**I/O Board Part Number**

P/N 191913		4-20 mA INPUT (4)			
		TBxA - INPUTS 1-3		TBxB - INPUT 4	
TB	Ch	2 Wire Loop	2 Wire Pwr	3 Wire	4 Wire
1	1,4		XMTR-		XMTR-
2		XMTR-	XMTR+	XMTR+	XMTR+
3		+24V		+24V	+24V
4				COM(-)	24V(-)
5	2		XMTR-		XMTR-
6		XMTR-	XMTR+	XMTR+	XMTR+
7		+24V		+24V	+24V
8				COM(-)	24V(-)
9	3		XMTR-		XMTR-
10		XMTR-	XMTR+	XMTR+	XMTR+
11		+24V		+24V	+24V
12				COM(-)	24V(-)
13-18					



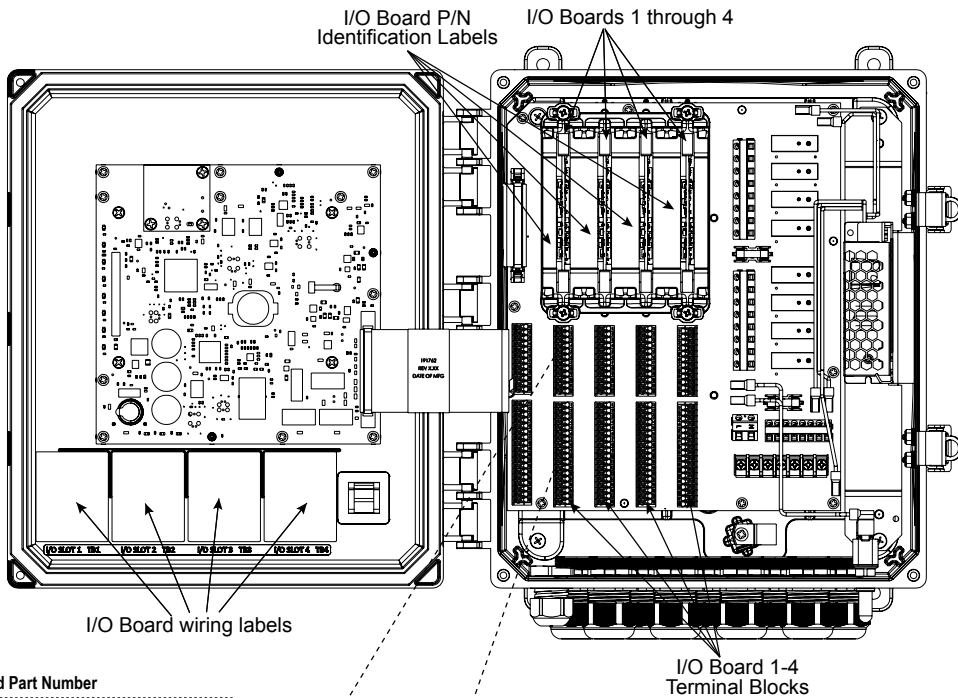
**Notes:**

Identify P/N 191913 I/O Board and connect wires to the terminal blocks directly below the I/O slot that the board is in.

Use the wiring label located on the front panel that has a matching I/O part number.

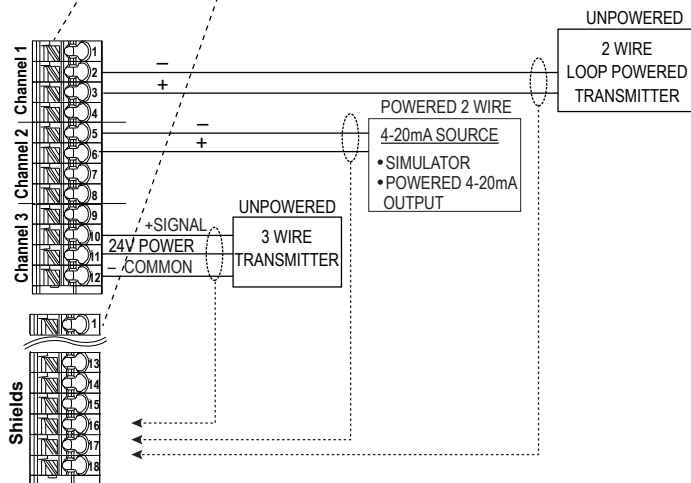
Either channel can support any of the sensor types listed.

To program the analog input, go to the Inputs menu, enter the menu for the I/O slot# and channel# (for example S21). Scroll to Transmitter and select the type of transmitter from the list.



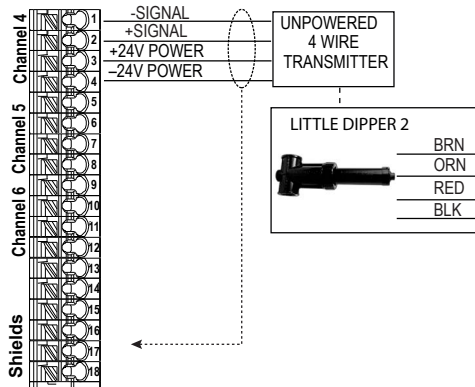
**I/O Board Part Number**

P/N 191914		4-20 mA INPUT (6)			
		TBxA - INPUTS 1-3		TBxB - INPUTS 4-6	
TB	Ch	2 Wire Loop	2 Wire Pwr	3 Wire	4 Wire
1	1,4		XMTR-	XMTR-	XMTR-
2		XMTR-	XMTR+	XMTR+	XMTR+
3		+24V		+24V	+24V
4				COM(-)	24V(-)
5	2,5		XMTR-	XMTR-	XMTR-
6		XMTR-	XMTR+	XMTR+	XMTR+
7		+24V		+24V	+24V
8				COM(-)	24V(-)
9	3,6		XMTR-	XMTR-	XMTR-
10		XMTR-	XMTR+	XMTR+	XMTR+
11		+24V		+24V	+24V
12				COM(-)	24V(-)
13-18					



**I/O Board Part Number**

P/N 191914		4-20 mA INPUT (6)			
		TBxA - INPUTS 1-3		TBxB - INPUTS 4-6	
TB	Ch	2 Wire Loop	2 Wire Pwr	3 Wire	4 Wire
1	1,4		XMTR-	XMTR-	XMTR-
2		XMTR-	XMTR+	XMTR+	XMTR+
3		+24V		+24V	+24V
4				COM(-)	24V(-)
5	2,5		XMTR-	XMTR-	XMTR-
6		XMTR-	XMTR+	XMTR+	XMTR+
7		+24V		+24V	+24V
8				COM(-)	24V(-)
9	3,6		XMTR-	XMTR-	XMTR-
10		XMTR-	XMTR+	XMTR+	XMTR+
11		+24V		+24V	+24V
12				COM(-)	24V(-)
13-18					



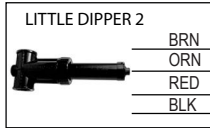
**Notes:**

Identify P/N 191914 I/O Board and connect wires to the terminal blocks directly below the I/O slot that the board is in.

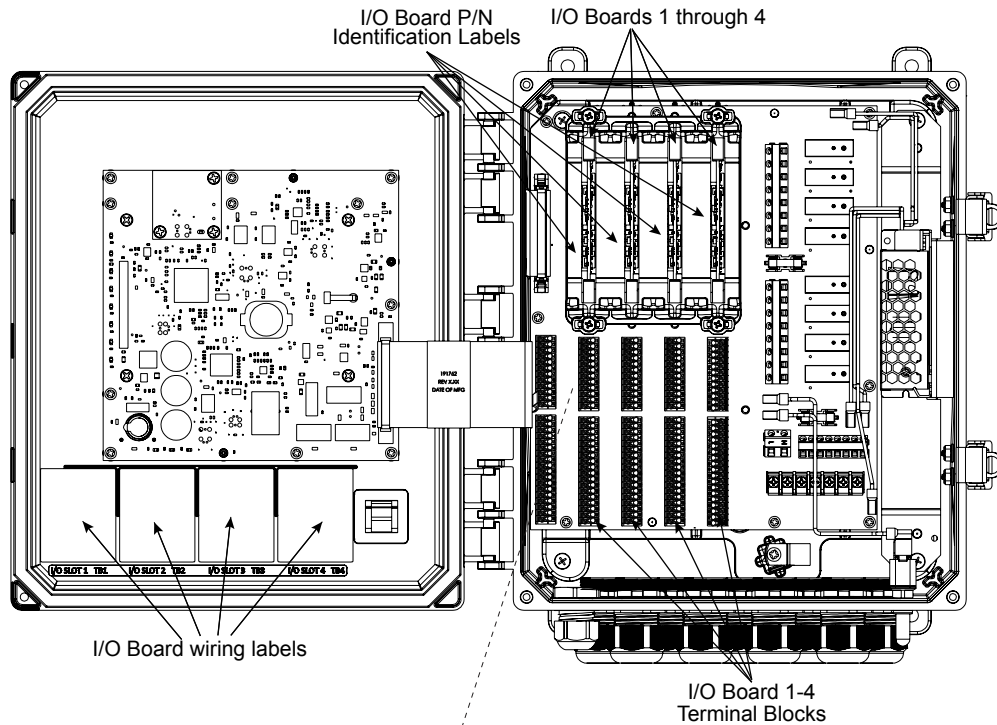
Use the wiring label located on the front panel that has a matching I/O part number.

Either channel can support any of the sensor types listed.

To program the analog input, go to the Inputs menu, enter the menu for the I/O slot# and channel# (for example S21). Scroll to Transmitter and select the type of transmitter from the list.

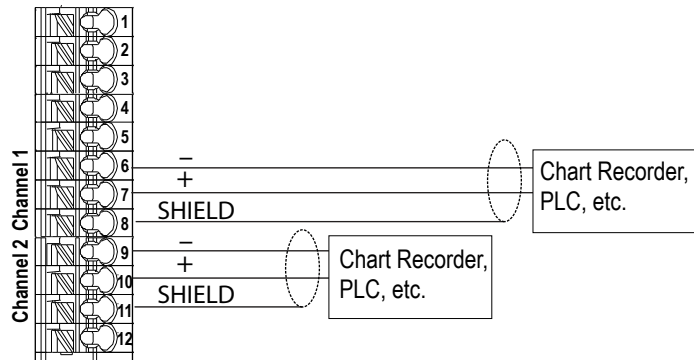


**Figure 12 Part Number 191914 Six Analog (4-20mA) Sensor Input Board Wiring**



**I/O Board Part Number**

P/N 191915		4-20 mA OUTPUT (2)	
TBxA - OUTPUTS 1-2		4-20 mA Output	
TBxB - NOT USED			
TB	Ch		
1			
2			
3			
4			
5			
6	Out 1	OUT-	
7		OUT+	
8		⊥	
9	Out 2	OUT-	
10		OUT+	
11		⊥	
12			
13-18			



**Notes:**

Identify P/N 191915 I/O Board and connect wires to the terminal blocks directly below the I/O slot that the board is in.

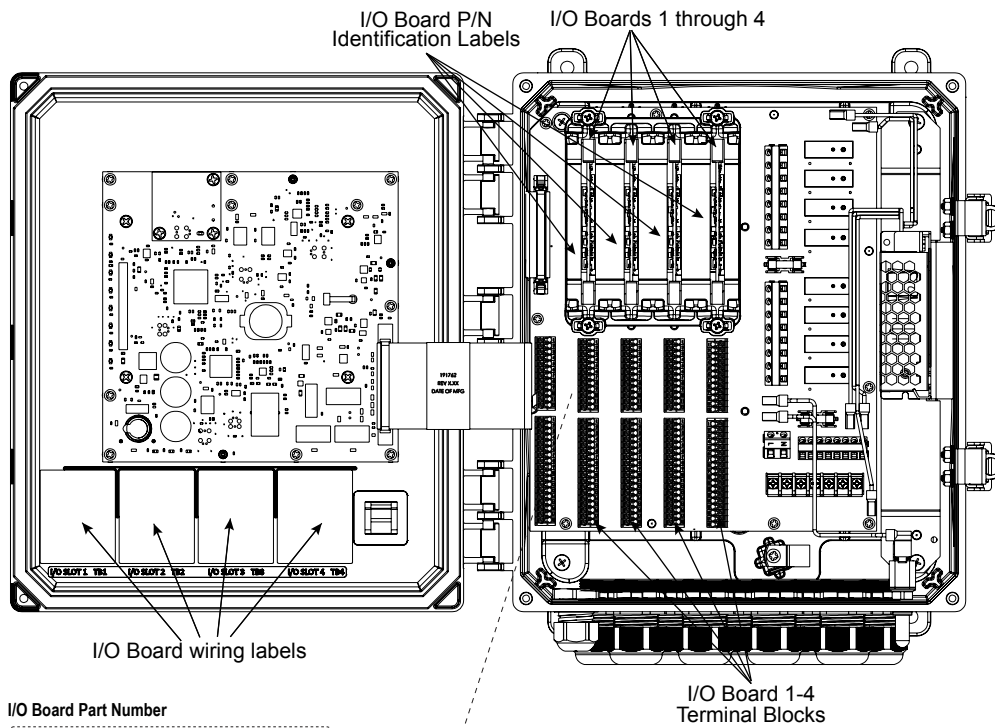
Use the wiring label located on the front panel that has a matching I/O part number.

Either channel can support any of the sensor types listed.

Each analog output is internally powered, 15 VDC, fully isolated.

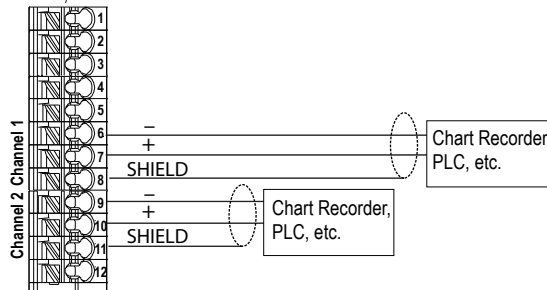
**Figure 13 Part Number 191915 Dual Analog (4-20mA) Output Wiring**





I/O Board Part Number

P/N 191916		4-20 mA OUTPUT (4)	
TBxA - OUTPUTS 1-2			
TBxB - OUTPUTS 3-4			
TB	Ch	4-20 mA Output	
1			
2			
3			
4			
5			
6		OUT-	
7	Out	OUT+	
8	1,3	⊥	
9		OUT-	
10	Out	OUT+	
11	2,4	⊥	
12			
13-18		⊥	



**Notes:**

Identify P/N 191916 I/O Board and connect wires to the terminal blocks directly below the I/O slot that the board is in.

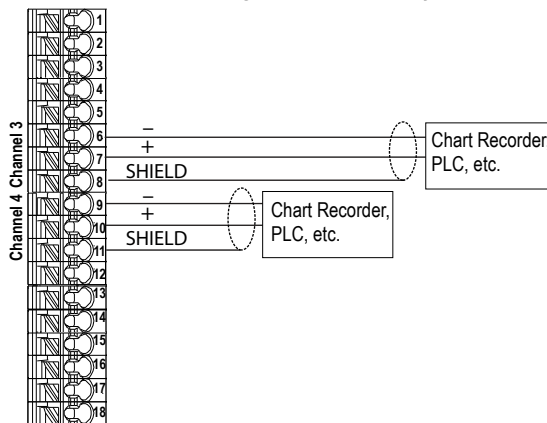
Use the wiring label located on the front panel that has a matching I/O part number.

Either channel can support any of the sensor types listed.

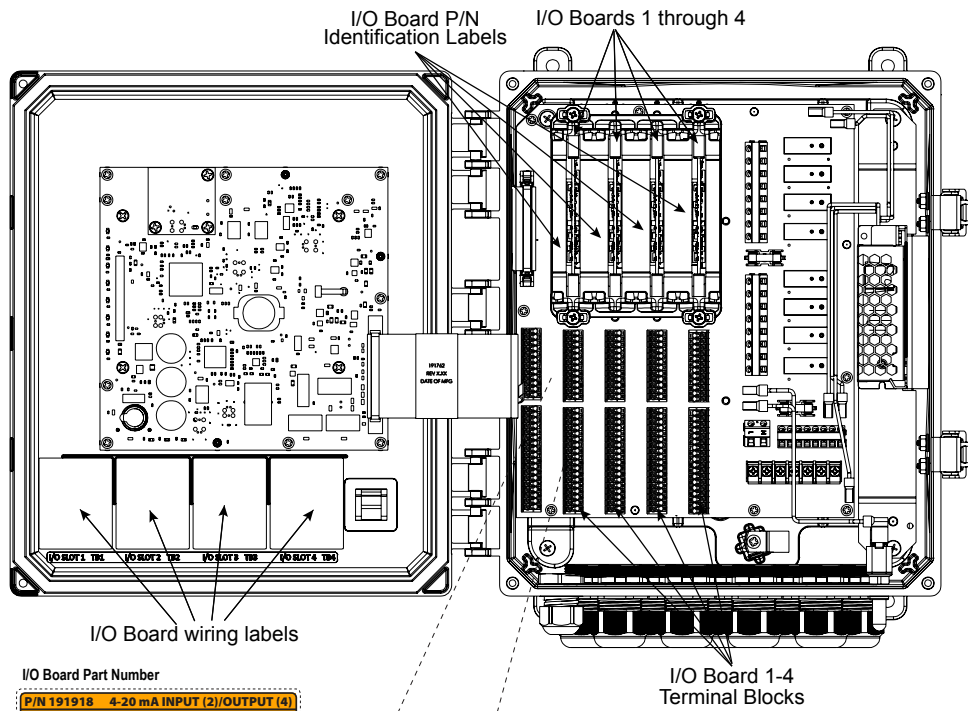
Each analog output is internally powered, 15 VDC, fully isolated.

I/O Board Part Number

P/N 191916		4-20 mA OUTPUT (4)	
TBxA - OUTPUTS 1-2			
TBxB - OUTPUTS 3-4			
TB	Ch	4-20 mA Output	
1			
2			
3			
4			
5			
6		OUT-	
7	Out	OUT+	
8	1,3	⊥	
9		OUT-	
10	Out	OUT+	
11	2,4	⊥	
12			
13-18		⊥	

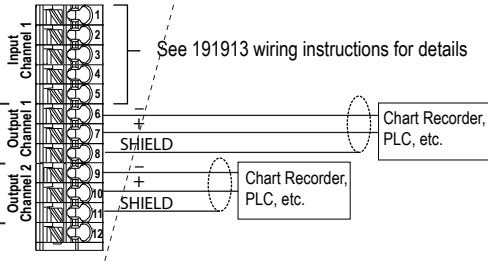


**Figure 14 Part Number 191916 Four Analog (4-20mA) Output Wiring**



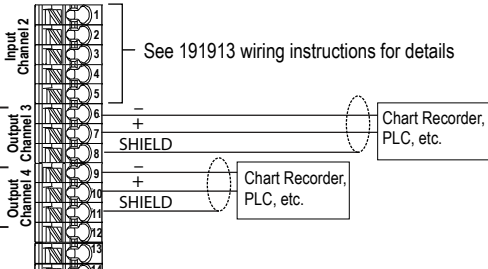
I/O Board Part Number

P/N 191918 4-20 mA INPUT (2)/OUTPUT (4)						
TBxA - INPUT 1, OUTPUTS 1-2						
TBxB - INPUT 2, OUTPUTS 3-4						
TB	Ch	2 Wire Loop	2 Wire Pwr	3 Wire	4 Wire	4-20 mA Output
1						
2						
3	In					
4	1,2	+24V				
5						
6						
7	Out					OUT-
8	1,3					OUT+
9						
10	Out					OUT-
11	2,4					OUT+
12						
13-18						



I/O Board Part Number

P/N 191918 4-20 mA INPUT (2)/OUTPUT (4)						
TBxA - INPUT 1, OUTPUTS 1-2						
TBxB - INPUT 2, OUTPUTS 3-4						
TB	Ch	2 Wire Loop	2 Wire Pwr	3 Wire	4 Wire	4-20 mA Output
1						
2						
3	In					
4	1,2	+24V				
5						
6						
7	Out					OUT-
8	1,3					OUT+
9						
10	Out					OUT-
11	2,4					OUT+
12						
13-18						



**Notes:**

Identify P/N 191918 I/O Board and connect wires to the terminal blocks directly below the I/O slot that the board is in.

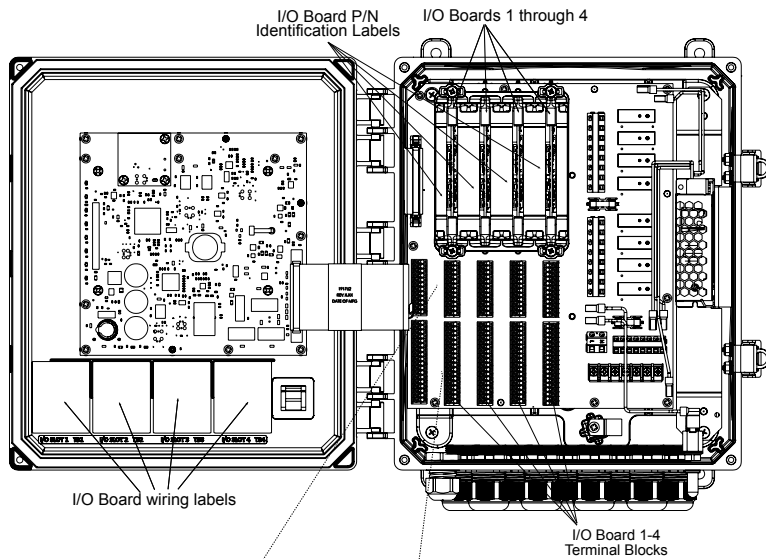
Use the wiring label located on the front panel that has a matching I/O part number.

Either channel can support any of the sensor types listed.

Each analog output is internally powered, 15 VDC, fully isolated.

To program the analog input, go to the Inputs menu, enter the menu for the I/O slot# and channel# (for example S21). Scroll to Transmitter and select the type of transmitter from the list.

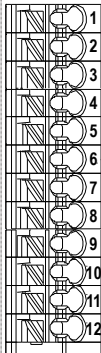
**Figure 15 Part Number 191918 Dual Analog (4-20mA) Input + Four Analog (4-20mA) Output Wiring**



I/O Board Part Number

P/N 191920		CORROSION INPUT(2)
		TBxA - SENSOR 1
		TBxB - SENSOR 2
TB	Ch	CORROSION
1	1,2	
2		
3		
4		
5		
6		XMT (Red)
7		RCV (Green)
8		MON RCV (Black)
9		MON XMT (White)
10		
11		
12		
13-18		SHIELD

Channel 1



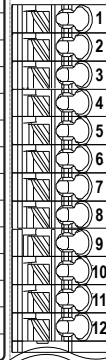
XMT RED  
RCV GRN  
MON RCV BLK  
MON XMT WHT

SHIELD

I/O Board Part Number

P/N 191920		CORROSION INPUT(2)
		TBxA - SENSOR 1
		TBxB - SENSOR 2
TB	Ch	CORROSION
1	1,2	
2		
3		
4		
5		
6		XMT (Red)
7		RCV (Green)
8		MON RCV (Black)
9		MON XMT (White)
10		
11		
12		
13-18		SHIELD

Channel 2

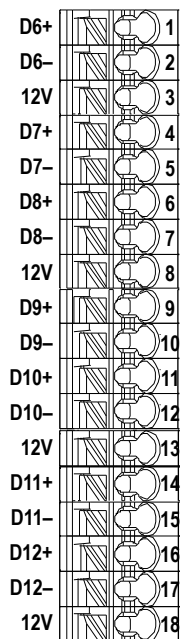
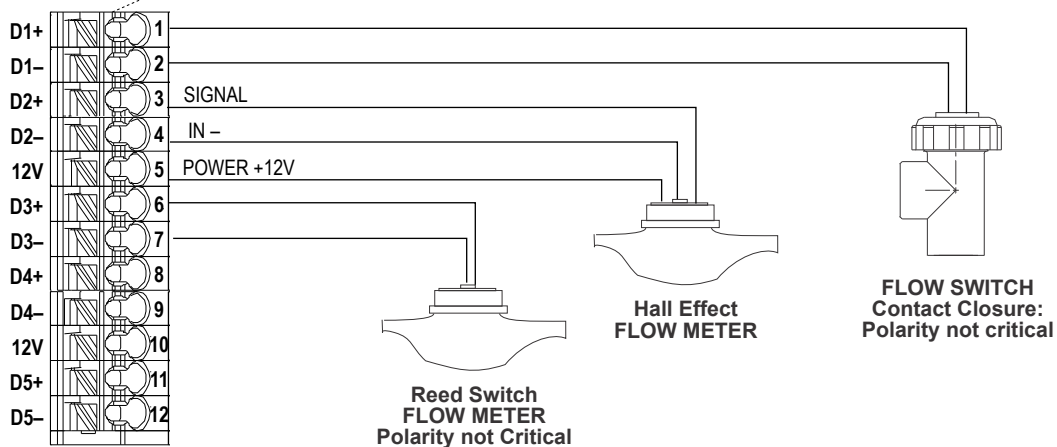
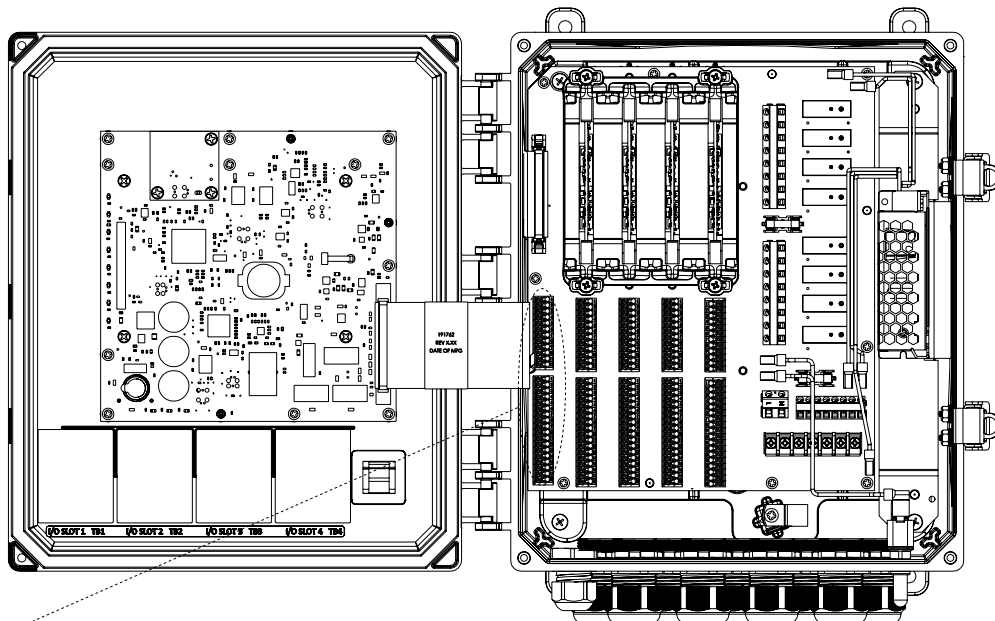


XMT RED  
RCV GRN  
MON RCV BLK  
MON XMT WHT

SHIELD

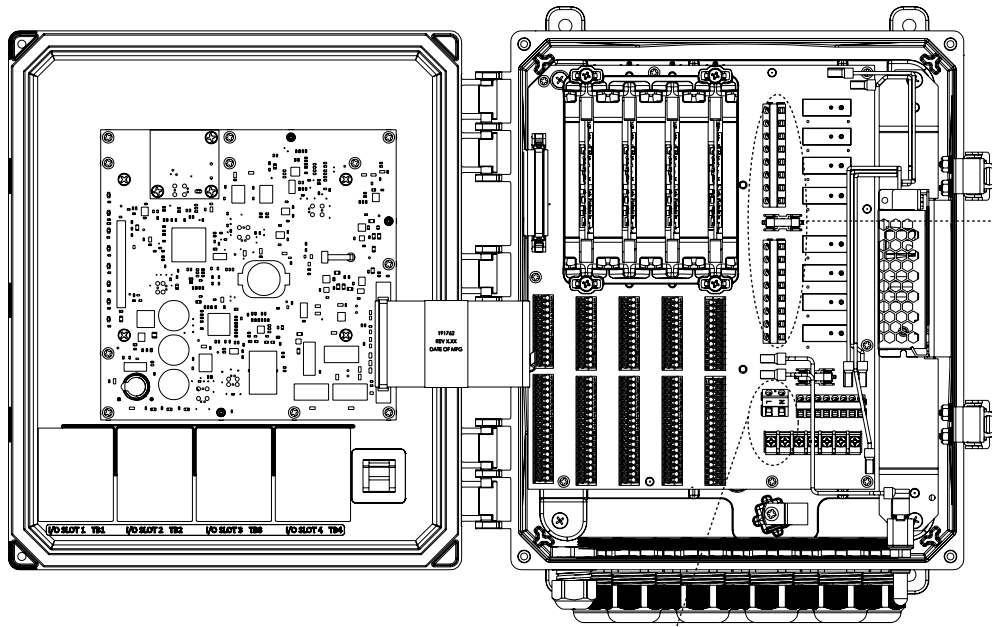
**Notes:**  
Identify P/N 191920 I/O Board and connect wires to the terminal blocks directly below the I/O slot that the board is in.  
Use the wiring label located on the front panel that has a matching I/O part number.  
Either channel can support any of the sensor types listed.

**Figure 16 Part Number 191920 Dual Corrosion Sensor Input Board Wiring**

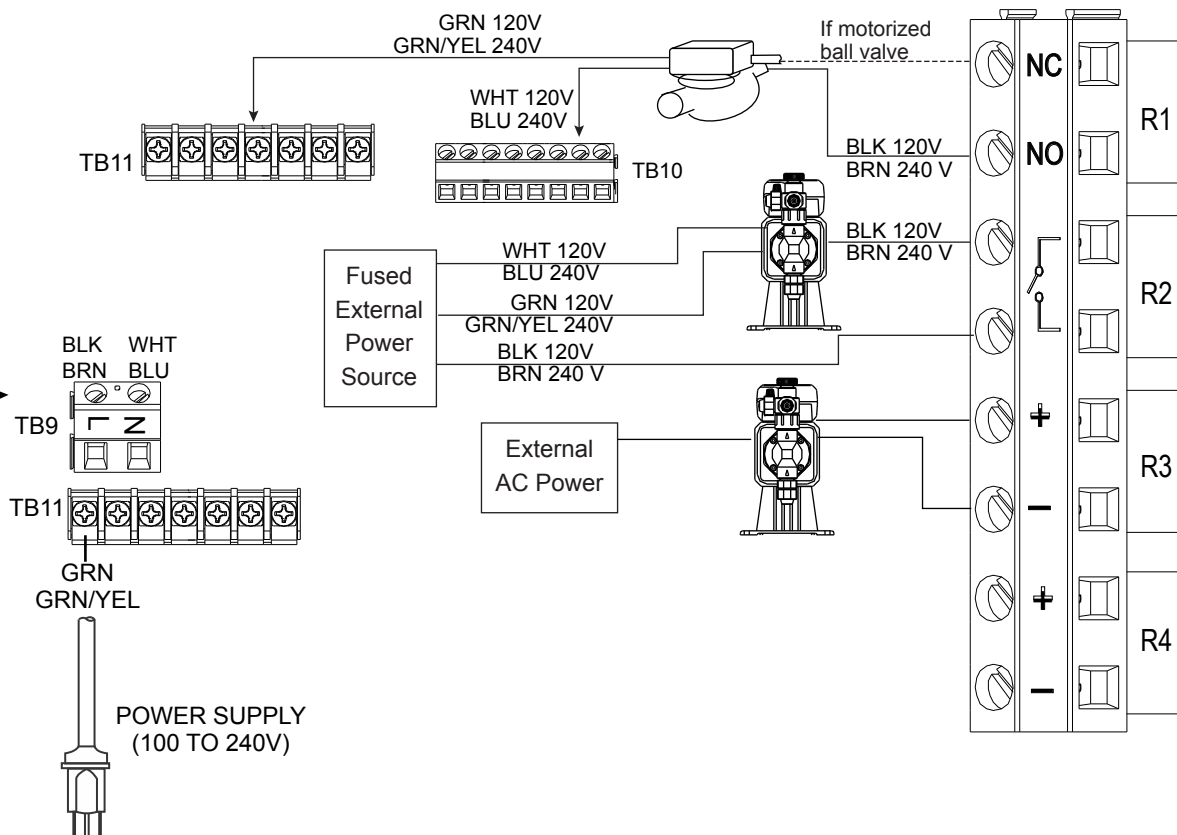


TBDI

Figure 17 Digital Input Wiring



Relay Model Code	R1	R2	R3	R4	R5	R6	R7	R8
900	Powered	Powered	Powered	Powered	Powered	Powered	Powered	Powered
910	Powered	Powered	Powered	Powered	Powered	Powered	Powered	Dry
920	Dry	Dry	Dry	Dry	Dry	Dry	Pulse	Pulse
930	Powered	Powered	Dry	Dry	Powered	Powered	Dry	Dry
940	Dry	Dry	Pulse	Pulse	Dry	Dry	Pulse	Pulse
950	Powered	Powered	Pulse	Pulse	Powered	Powered	Pulse	Pulse
960	Powered	Powered	Powered	Powered	Powered	Powered	Pulse	Pulse
970	Dry	Dry	Dry	Dry	Dry	Dry	Dry	Dry



**Figure 18 AC Power & Relay Output Wiring**

## 4.0 FUNCTION OVERVIEW

---

### 4.1 Front Panel



Figure 19 Front Panel

### 4.2 Touchscreen

A Home screen is displayed while the controller is on. This display shows a user-defined list of input readings or status of outputs. Touching any of the items on the Home Screen will bring up the item's Details Screen, where you can access calibration and setting menus. If more than four items have been selected to be displayed on the Home screen, the display will toggle between the first group of up to four and the next group. A “pause button” icon, when touched, stops the automatic toggling. Touching the down arrow icon allows for manual toggling. Touching the “play button” icon enables automatic toggling again. Touching the Menu icon brings up the Main Menu screen.

### 4.3 Icons

The following icons appear on the Home screen.



The Main Menu icon brings you to the list of menu options listed below.

The following icons appear on the Main Menu screen. Touch the icon to get to the menu selections.



Alarm Menu



Inputs Menu



Outputs Menu



Configuration Menu



HOA Menu



Graph Menu



Home Page

Other icons may appear in the menu screens.



Calibration icon appears in sensor input menus and brings up the calibration menu



Cancel icon aborts a calibration or setting change



The Page Down icon scrolls down to a new page in a list of options.



The Page Up icon scrolls up to a new page in a list of options.



The Back/Return icon returns the display to the previous screen



The Make Character Higher icon is used when making an alphanumeric entry



The Make Character Lower icon is used when making an alphanumeric entry



The Move Cursor icon is used to scroll left to right within an alphanumeric entry



The Confirm icon accepts a choice, finishes entering data, or advances to the next calibration step



Settings Menu



The Character Delete icon deletes part of an alphanumeric entry



The Shift icon switches between upper and lower case alpha entry screens



The Next Screen icon moves to the next step in a calibration sequence. In a Graph it shifts the graph forward in time.



The Previous Screen icon moves back a step in a calibration sequence. In a Graph it shifts the graph backwards in time.

## ***Overview of the use of icons***

### **Changing Numeric Values**

To change a number, use the Character Delete icon to the digit to be changed. If the new number will be negative, start with touching the minus sign, then use the numeric touchpad and decimal point to type the number (some entries must be integers and the decimal will be ignored and the setting rounded to the nearest integer). Once the value of the number is correct touch the Confirm icon to store the new value into memory, or touch the Cancel icon to leave the number at its previous value and go back.

### **Changing Names**

To change the name used to identify an input or output, use the Move Cursor icon to the character to be changed and change it using either the Make Character Higher or Lower icons. Upper case and lower case letter, numbers, a blank space, period, plus and minus symbols are available. Move the cursor to the right and modify each character. Once the word is correct, use the Enter icon to store the new value into memory, or use the Cancel icon to leave the word at its previous value and go back.

### **Choosing from a List**

Selecting the type of sensor, the units of measure of an input, or the control mode used for an output, the selection is picked from a list of available options. Touch the Page Up or Down icons if necessary to find the desired option, and then touch the option to highlight it. Touch the Confirm icon to store the new option into memory, or touch the Cancel icon to leave the selection at its previous value and go back.

### **Hand-Off-Auto Relay Mode**

Touch the desired relay mode. In Hand mode the relay is forced on for a specified amount of time and when that time is up the relay returns to its previous mode, in Off mode the relay is always off until taken out of Off mode, and in Auto mode the relay is responding to control set points. Touch the Return icon to go back to the relay settings.


### **Interlock and Activate with Channels Menus**

To select which digital inputs or relays will interlock this relay (Interlock Channels), or which digital inputs or relays will force this relay on (Activate with Channels), touch the input or relay number(s). The background of the selected item will turn dark. When finished selecting as many as needed, touch the Confirm icon to accept the changes or the Cancel icon to leave the selections at the previous settings and go back.

## **4.4 Startup**

### ***Initial Startup***

After having mounted the enclosure and wired the unit, the controller is ready to be started. Plug in the controller and turn on the power switch to supply power to the unit. The display will briefly show the model number and then revert to the normal summary (Home) display. Refer to section 5 below for more details on each of the settings.

To return to the summary display, touch the Main Menu icon  and then touch the Home icon.

### ***Config Menu (see section 5.4)***

#### **Choose language**

Touch the Configuration Settings icon. Touch Global Settings. Touch the Scroll Down icon until the English word “Language” is displayed and then touch it. Touch the Scroll Down icon until your language is displayed and touch it. Touch the Confirm icon to change all menus to your language.

#### **Set date (if necessary)**

Touch the Scroll Up or Down icon until Date is displayed, and then touch it. Touch the Move Cursor icon to highlight the Day, and then use the numeric touchpad to change the date. Touch the Confirm icon to accept the change.

#### **Set time (if necessary)**

Touch the Scroll Up or Down icon until Time is displayed and then touch it. Touch the Move Cursor icon to highlight the digit to change, then use the numeric touchpad to change the time. Touch the Confirm icon to accept the change.



### **Set global units of measure**

Touch the Scroll Up or Down icon until Global Units is displayed and then touch it. Touch the desired units. Touch the Confirm icon to accept the change.

### **Set temperature units of measure**

Touch the Scroll Up or Down icon until Temp Units is displayed and then touch it. Touch the desired units. Touch the Confirm icon to accept the change.

Touch the Main Menu icon. Touch the Inputs icon.

## ***Inputs (see section 5.2)***

### **Program the settings for each input**

The S11 sensor input will be displayed. Touch it to get to the Details screen. Touch the Settings icon. If the name of the sensor does not describe the type of sensor connected, touch the Scroll Down icon until Type is displayed. Touch the Type field. Touch the Scroll Down icon until the correct type of sensor is displayed, then touch it to highlight it. Touch the Confirm icon to accept the change. This will bring you back to the Settings screen. Finish the rest of the S1 settings. For disinfections sensors, choose the exact sensor in the Sensor menu. For contacting conductivity sensors, enter the cell constant. Select the units of measure. Enter the alarm set points and alarm deadband. Set the default temperature that will be used for automatic temperature compensation if the temperature signal becomes invalid.

When finished with S11, touch the Return icon until the list of inputs is displayed. Touch the Scroll Down icon and repeat the process for each input.

The S12 temperature input Element should be set correctly once the S11 sensor type has been set. If not, select the correct temperature element and set the alarm set points and alarm deadband. Generic, ORP and disinfection sensors do not have temperature signals and are preset to Unassigned.

To calibrate the temperature, return to the S12 Details screen, touch the Calibrate icon, and touch the Enter icon to perform a calibration. If either input card is a Dual Analog Input card (4-20mA signal), then select the type of sensor that will be connected. Select Fluorometer if a Little Dipper 2 will be connected. Select AI Monitor if the device can be calibrated on its own and the OnGuard™ P900 series calibration will only be in units of mA. Select Transmitter if the device connected cannot be calibrated on its own and the OnGuard™ P900 series will need to be used to calibrate in engineering units of measure.

If a flow switch or liquid level switch is connected, D1 through D12 (whichever one has the device connected to it) should be set to DI State type (if no switch is connected, select No Sensor). Set the state that will possibly interlock control outputs (refer to the Outputs settings to program which outputs, if any, will be interlocked by the switch). Set the state, if any, that will result in an alarm.

If a contacting head or paddlewheel flow meter is connected, D1 through D12 (whichever one has the device connected to it) should be set to that type (if no flow meter is connected, select No Sensor). Set the units of measure, volume/contact or K factor, etc.

### **Calibrate the sensor**

To calibrate the sensor, return to the list of inputs, touch the sensor to calibrate, touch the Calibrate icon, and select one of the calibration routines. For disinfection and Generic sensors, start with the Zero Calibration. For electrodeless conductivity, start with the Air Calibration. Refer to section 5.2.

Touch the Main Menu icon. Touch the Outputs icon.

# MAIN MENU/HOME SCREEN OVERVIEW

Inputs	
Sensor (S11)	3038 $\mu$ S/cm
Temp (S12)	77.1°F
Generic AI (S21)	30.5%
Generic AI (S22)	37.9%

- List of possible Inputs:  
 Contacting Conductivity  
 Electrodeless Conductivity  
 Temperature  
 pH  
 ORP  
 Disinfection  
 Generic  
 Transmitter/AI Monitor  
 Tank Level  
 Fluorometer  
 Flowmeter, Analog Type  
 DI State  
 Flow Meter, Contactor type  
 Flow Meter, Paddlewheel type  
 Feed Monitor  
 Counter  
 Remote Modbus DI State  
 DI Counter  
 Calculation Virtual Input  
 Redundant Sensor Virtual Input  
 Raw Value Virtual Input  
 Disturbance Virtual Input  
 Remote Modbus Virtual Input  
 Corrosion Rate  
 Corrosion Imbalance

Outputs	
On/Off (R1)	Off
Flow Timer (R2)	Off
Flow Timer (R3)	Off
Manual (R4)	Off

- List of possible Outputs:  
 On/Off control mode  
 On/Off Disturbance control mode  
 Flow Timer control mode  
 Bleed & Feed control mode  
 Bleed Then Feed control mode  
 Percent Timer control mode  
 Biocide Timer control mode  
 Alarm Output mode  
 Time Proportional control mode  
 Pulse Mass Balance  
 Pulse Proportional control mode  
 Pulse Proportional Disturbance control mode  
 Intermittent Sampling mode  
 Manual control mode  
 PID control mode  
 Dual Setpoint mode  
 Timer control mode  
 Probe Wash control mode  
 Spike control mode  
 Lag Output control mode  
 Mass Balance  
 PPM Volume  
 Flow Meter Ratio control mode  
 Volumetric Blend control mode  
 Counter Timer  
 Boolean Logic  
 Dual Switch mode  
 Counter Timer  
 Analog Output, Retransmit mode  
 Analog Output, Proportional control mode  
 Analog Output, PID control mode  
 Analog Output, Manual mode  
 Analog Output, Mass Balance  
 Analog Output, Disturbance Mode

Alarms	
List of all Active Alarms	

## HOME SCREEN (example)

Flowswitch (D1) No Flow	
CCond (S11)	3041 $\mu$ S/cm
Temp (S12)	77.0°F
Flowswitch (D1)	No Flow

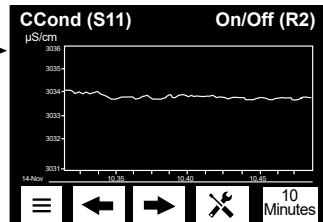
## MAIN MENU

Main Menu 09:19:01 14-Mar-2017			
Inputs	Config	HOA	Graph
Outputs	Alarm	To HOME SCREEN	

Config	
Global Settings	
Security Settings	
Ethernet Settings	
Ethernet Details	

- Additional Config Settings:  
 WiFi Settings  
 WiFi Details  
 Remote Communications (Modbus)/BACnet  
 Email Report Settings  
 Display Settings  
 File Utilities  
 Controller Details

> HOA			
R1	R2	R3	R4
R5	R6	R7	R8
Hand	Off	Auto	.

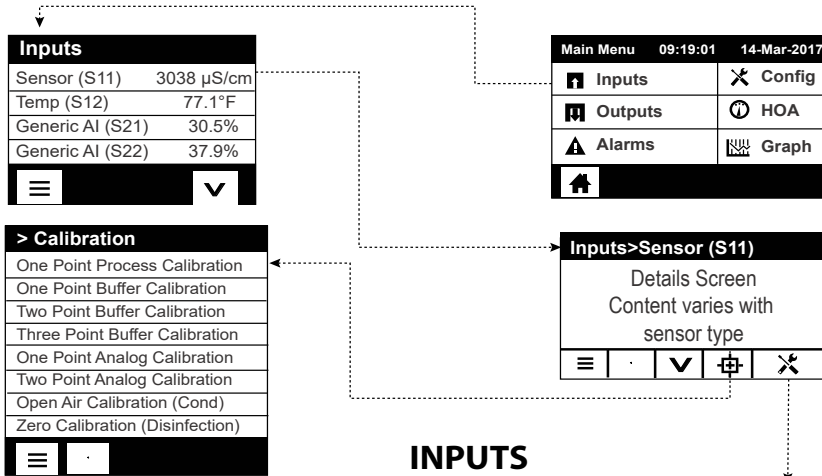


Graph Settings	
Sensor	
DI Relay	
Low Axis Limit	
High Axis Limit	

- Additional Graph Settings:  
 Time Range

Time Range	
10 Minutes	
30 Minutes	
1 Hour	
2½ Hours	

- More possible settings:  
 8 Hours  
 12 Hours  
 1 Day  
 ½ Week  
 1 Week  
 2 Weeks  
 4 Weeks



## INPUTS

**Contacting Cond S11-43**

Alarms  
Deadband  
Reset Calibration Values  
Cal Required Alarm

Additional Settings for Contacting Conductivity:

Alarm & Datalog Suppression  
Smoothing Factor  
Default Temp  
Temp Compensation  
Cell Constant

Cable Length  
Gauge  
Units  
Name  
Type

**Electrodeless Cond S11-43**

Alarms  
Deadband  
Reset Calibration Values  
Cal Required Alarm

Additional Settings for Electrodeless Conductivity:

Alarm & Datalog Suppression  
Smoothing Factor  
Default Temp  
Installation Factor  
Range  
Temp Compensation

Temp Comp Factor  
Cell Constant  
Cable Length  
Gauge  
Units  
Name  
Type

**Temperature S11-43**

Alarms  
Deadband  
Reset Calibration Values  
Cal Required Alarm

Additional Settings for Temperature Sensor:

Alarm & Datalog Suppression  
Smoothing Factor  
Name  
Element

**pH S11-43**

Alarms  
Deadband  
Reset Calibration Values  
Cal Required Alarm

Additional Settings for pH Sensor:

Alarm & Datalog Suppression  
Smoothing Factor  
Buffers (pH only)  
Default Temp

Cable Length  
Gauge  
Electrode  
Name  
Type

**ORP S11-43**

Alarms  
Deadband  
Reset Calibration Values  
Cal Required Alarm

Additional Settings for ORP Sensor:

Alarm & Datalog Suppression  
Smoothing Factor  
Cable Length  
Gauge

Name  
Type

**Disinfection S11-43**

Alarms  
Deadband  
Reset Calibration Values  
Cal Required Alarm

Additional Settings for Disinfection Sensor:

Alarm & Datalog Suppression  
Smoothing Factor  
Cable Length  
Gauge  
Name

Sensor  
Type

**Generic S11-43**

Alarms  
Deadband  
Reset Calibration Values  
Cal Required Alarm

Additional Settings for Generic Sensor:

Alarm & Datalog Suppression  
Smoothing Factor  
Sensor Slope  
Sensor Offset  
Low / High Range  
Cable Length

Gauge  
Units  
Electrode (Linear or Ion Selective)  
Name  
Type

**Transmitter / AI Monitor S11-S46**

Alarms  
Deadband  
Reset Calibration Values  
Cal Required Alarm

Additional Settings for Transmitter and AI Monitor:

Alarm & Datalog Suppression  
Smoothing Factor  
Transmitter  
4 mA Value

20 mA Value  
Units  
Name  
Type

**Tank Level S11-S46**

Alarms  
Deadband  
Reset Calibration Values  
Alarm & Datalog Suppression

Additional Settings for Tank Level:

Units  
Tank Capacity  
Empty At  
Full At

Smoothing Factor  
Transmitter  
Name  
Type

**Fluorometer S11-S46**

Alarms  
Deadband  
Reset Calibration Values  
Cal Required Alarm

Additional Settings for Fluorometer:

Alarm & Datalog Suppression  
Smoothing Factor  
Transmitter

Max Sensor Range  
Dye / Product Ratio  
Name  
Type

**Flowmeter S11-S46**

Alarms  
Deadband  
Reset Flow Total  
Set Flow Total

Additional Settings for Flowmeter:

Scheduled Reset  
Reset Calibration Values  
Reset Flow Total  
Alarm & Datalog Suppression  
Smoothing Factor  
Transmitter

Flow Units  
Rates Units  
Flowmeter Max  
Input Filter  
Name  
Type

**Corrosion S11-S41**

Alarms  
Deadband  
Replace Corrosion Electrode  
Stabilization Time

Additional Settings for Corrosion:

Electrode Alarm  
Alarm & Datalog Suppression  
Reset Calibration Values  
Cal Required Alarm  
Smoothing Factor

Cycle Time  
Range  
Units  
Name  
Type

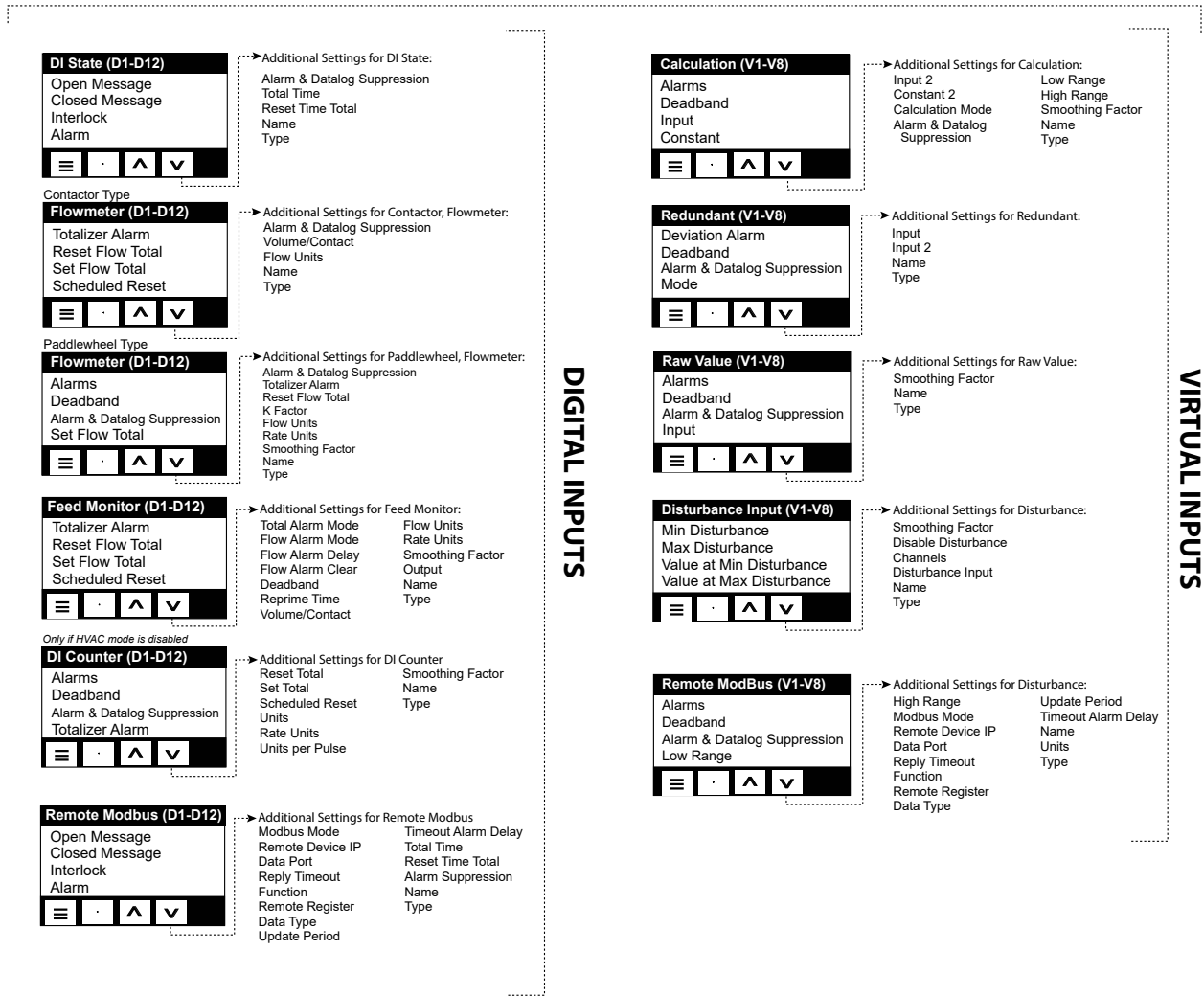
**Imbalance S12-S44**

Alarms  
Deadband  
Alarm & Datalog Suppression  
Reset Calibration Values

Additional Settings for Imbalance:

Cal Required Alarm  
Name  
Type

# INPUTS



# RELAY OUTPUTS (R1-R8) and VIRTUAL OUTPUTS (C1-C8)

(CONTINUED ON NEXT PAGE)

**Outputs**

On/Off (R1)	Off
Inhibitor (R2)	Off
Flow Timer (R3)	Off
Manual (R4)	Off

Main Menu 09:19:01 14-Mar-2017

Inputs	Config
Outputs	HOA
Alarms	Graph

**Outputs>On/Off (R1)**

Details Screen  
Content varies with output type

**On/Off (R1-R8)**

HOA Setting  
Set Point  
Deadband  
Duty Cycle Period

Additional Settings for On/OFF Mode:

Duty Cycle	Minimum Relay Cycle
On Delay Time	Hand Time Limit
Off Delay Time	Reset Time Total
Daily Max Time	Input
Output Time Limit	Direction
Reset Output Timeout	Name
Interlock Channels	Mode
Activate with Channels	

**Flow Timer (R1-R8)**

HOA Setting  
Feed Duration  
Accumulated Volume  
Reset Timer

Additional Settings for Flow Timer Mode:

Daily Max Time	Hand Time Limit
Output Time Limit	Reset Time Total
Reset Output Timeout	Flow Input
Interlock Channels	Flow Input 2
Activate with Channels	Name
Minimum Relay Cycle	Mode

*Only if HVAC mode is enabled*

**Bleed & Feed (R1-R8)**

HOA Setting  
Feed Time Limit  
Daily Max Time  
Reset Output Timeout

Additional Settings for Bleed & Feed Mode:

Interlock Channels	Bleed
Activate with Channels	Name
Minimum Relay Cycle	Mode
Hand Time Limit	
Reset Time Total	

*Only if HVAC mode is enabled*

**Bleed then Feed (R1-R8)**

HOA Setting  
Feed Percentage  
Feed Time Limit  
Reset Timer

Additional Settings for Bleed then Feed Mode:

Daily Max Time	Hand Time Limit
Output Time Limit	Reset Time Total
Reset Output Timeout	Bleed
Interlock Channels	Name
Activate with Channels	Mode
Minimum Relay Cycle	

**Percent Timer (R1-R8)**

HOA Setting  
Sample Period  
Feed Percentage  
Output Time Limit

Additional Settings for Percent Timer Mode:

Reset Output Timeout	Name
Interlock Channels	Mode
Activate with Channels	
Minimum Relay Cycle	
Hand Time Limit	
Reset Time Total	

*Only if HVAC mode is enabled*

**Biocide Timer (R1-R8)**

HOA Setting  
Event 1 (through 10)  
Repetition  
Week  
Day  
Start Time  
Duration

Additional Settings for Biocide Timer Mode:

Bleed	Activate with Channels
Prebleed Time	Minimum Relay Cycle
Prebleed To	Hand Time Limit
Repetition	Reset Time Total
Week	Name
Day	Mode
Start Time	
Duration	
Interlock Channels	

**Alarm (R1-R8)**

HOA Setting  
Alarm Mode  
On Delay Time  
Off Delay Time

Additional Settings for Alarm Mode:

Select Alarms	Hand Time Limit
Output	Reset Time Total
Interlock Channels	Name
Activate with Channels	Mode
Channels	
Minimum Relay Cycle	

**Time Prop (R1-R8)**

HOA Setting  
Set Point  
Proportional Band  
Sample Period

Additional Settings for Time Prop Mode:

Daily Max Time	Reset Time Total
Output Time Limit	Input
Reset Output Timeout	Direction
Interlock Channels	Name
Activate with Channels	Mode
Minimum Relay Cycle	
Hand Time Limit	

*Only if HVAC mode is enabled*

**Int. Sampling (R1-R8)**

HOA Setting  
Set Point  
Proportional Band  
Deadband

Additional Settings for Intermittent Sampling Mode:

Sample Time	Min Relay Cycle
Hold Time	Hand Time Limit
Maximum Blowdown	Reset Time Total
Wait Time	Cond Input
Output Time Limit	Trap Sample
Reset Output Timeout	Name
Interlock Channels	Mode
Activate with Channels	

**Manual (R1-R16)**

HOA Setting  
On Delay Time  
Off Delay Time  
Output Time Limit

Additional Settings for Manual Mode:

Reset Output Timeout	Name
Interlock Channels	Mode
Minimum Relay Cycle	
Hand Time Limit	
Reset Time Total	

*Only if Pulse Relay Type*

**Pulse Prop (R1-R8)**

HOA Setting  
Set Point  
Proportional Band  
Minimum/Maximum Output

Additional Settings for Pulse Prop Mode:

Maximum Rate	Input
Interlock Channels	Direction
Activate with Channels	Name
Minimum Relay Cycle	Mode
Hand Time Limit	
Reset Time Total	

*Only if Pulse Relay Type*  
*Only if HVAC mode is disabled*

**PID Control (R1-R8)**

HOA Setting  
Set Point  
Gain  
Proportional Gain

Additional Settings for PID Control Mode:

Integral Time	Input Maximum
Integral Gain	Gain Form
Derivative Time	Output Time Limit
Derivative Gain	Reset Output Timeout
Reset PID Integral	Interlock Channels
Minimum Output	Activate with Channels
Maximum Output	Minimum Relay Cycle
Maximum Rate	Hand Time Limit
Input	Reset Time Total
Direction	Name
Input Minimum	Mode

**Dual Setpoint (R1-R8)**

HOA Setting  
Set Point  
Set Point 2  
Deadband

Additional Settings for Dual Setpoint Mode:

Duty Cycle Period	Minimum Relay Cycle
Duty Cycle	Hand Time Limit
On Delay Time	Reset Time Total
Off Delay Time	Input
Output Time Limit	Direction
Reset Output Timeout	Name
Interlock Channels	Mode
Activate with Channels	

*Only if HVAC mode is disabled*

**Timer Control (R1-R8)**

HOA Setting  
Event 1 (through 10)  
Repetition  
Hourly

Additional Settings for Timer Control Mode:

Week	Interlock Channels
Day	Activate with Channels
Events Per Day	Minimum Relay Cycle
Start Time	Hand Time Limit
Duration	Reset Time Total
Add Last Missed	Name
Output Time Limit	Mode
Reset Output Timeout	

**Probe Wash (R1-R8)**

HOA Setting  
Event 1 (through 10)  
Repetition  
Hourly

Additional Settings for Probe Wash Mode:

Week	Hold Time
Day	Interlock Channels
Events Per Day	Activate with Channels
Start Time	Minimum Relay Cycle
Duration	Hand Time Limit
Input	Reset Time Total
Input 2	Name
Sensor Mode	Mode

**Spike Control (R1-R8)**

HOA Setting  
Set point  
Spike Setpoint  
Deadband

Additional Settings for Spike Control Mode:

Onset Time	Reset Output Timeout
Duty Cycle Period	Interlock Channels
Duty Cycle	Activate With Channels
Event 1 (through 6)	Min Relay Cycle
Repetition	Hand Time Limit
Week	Reset Time Total
Day	Input
Start Time	Direction
Duration	Name
Daily Max Time	Mode
Output Time Limit	

*Not available for virtual outputs*

**Lag Control (R1-R8)**

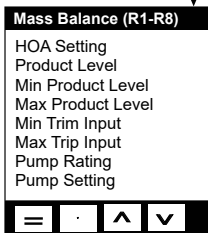
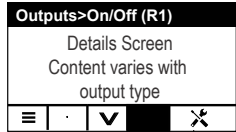
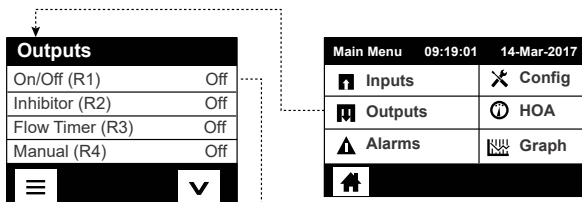
HOA Setting  
Lead  
Wear Leveling\*  
Wear Cycle Time\*

Additional Settings for Lag Control Mode:

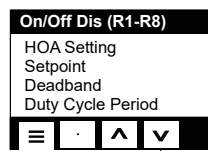
Activation Mode*	Activate with Channels
Set Point	Min Relay Cycle
Set Point 2	Hand Time Limit
Deadband	Reset Time Total
Delay Time*	Name
Output Time Limit	Mode
Reset Output Timeout	
Interlock Channels	

\* See section 5.3.18

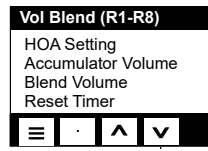
## RELAY OUTPUTS (R1-R8) and VIRTUAL OUTPUTS (C1-C8) Continued



- Additional Settings for Mass Balance Control Mode:
- Specific Gravity
  - Accumulator SetPoint
  - Reset Timer
  - Output Time Limit
  - Reset Output Timeout
  - Interlock Channels
  - Activate with Channels
  - Min Relay Cycle
  - Hand Time Limit
  - Reset Time Total
  - Flow Input
  - Flow Input 2
  - Cycles Input
  - Low Cycles Limit
  - Performance Input
  - Name
  - Mode

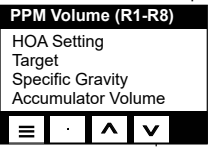


- Additional Settings for On/Off Dis:
- Duty Cycle
  - On Delay Time
  - Off Delay Time
  - Output Time Limit
  - Reset Output Timeout
  - Interlock Channels
  - Activate with Channels
  - Minimum Relay Cycle
  - Hand Time Limit
  - Reset Time Total
  - Input
  - Direction
  - Disturbance Input
  - Name
  - Mode

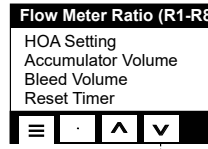


- Additional Settings for Vol Blend:
- Output Time Limit
  - Reset Output Timeout
  - Interlock Channels
  - Activate with Channels
  - Minimum Relay Cycle
  - Hand Time Limit
  - Reset Time Total
  - Flow Input
  - Disturbance Input
  - Name
  - Mode

Not available for virtual outputs

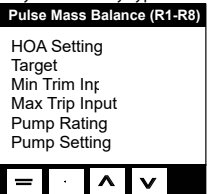


- Additional Settings for PPM Volume Control Mode:
- Reset Timer
  - Output Time Limit
  - Reset Output Timeout
  - Interlock Channels
  - Activate with Channels
  - Minimum Relay Cycle
  - Hand Time Limit
  - Reset Time Total
  - Flow Input
  - Flow Input 2
  - Cycles Input
  - Low Cycles Limit
  - Name
  - Mode

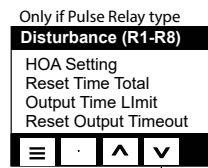


- Additional Settings for Flow Meter Ratio:
- Output Time Limit
  - Reset Output Timeout
  - Interlock Channels
  - Activate with Channels
  - Minimum Relay Cycle
  - Hand Time Limit
  - Reset Time Total
  - Makeup Meter
  - Makeup Meter 2
  - Bleed Meter
  - Bleed Meter 2
  - Disturbance Input
  - Name
  - Mode

Only if Pulse Relay Type

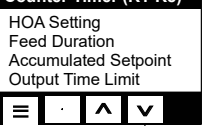


- Additional Settings for Pulse Mass Balance Control Mode:
- Specific Gravity
  - Maximum Rate
  - Output Time Limit
  - Reset Output Timeout
  - Interlock Channels
  - Activate with Channels
  - Hand Time Limit
  - Reset Time Total
  - Flow Input
  - Performance Input
  - Cycles Input
  - Low Cycles Limit
  - Name
  - Mode

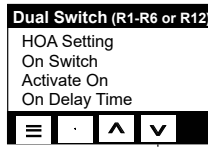


- Additional Settings for Disturbance:
- Min Output
  - Max Output
  - Interlock Channels
  - Activate with Channels
  - Hand Output
  - Hand Time Limit
  - Max Rate
  - Primary Output
  - Disturbance Input
  - Trigger Input
  - Activated
  - Trigger Mode
  - Name
  - Mode

Counter Timer (R1-R8)



- Additional Settings for Flow Timer Mode:
- Reset Output Timeout
  - Interlock Channels
  - Activate with Channels
  - Minimum Relay Cycle
  - Hand Time Limit
  - Reset Time Total
  - Input
  - Name
  - Mode



- Additional Settings for Dual Switch Mode:
- Off Switch
  - Activate Off
  - Off Delay Time
  - Hand Time Limit
  - Daily Max Time
  - Output Time Limit
  - Reset Output Timeout
  - Interlock Channels
  - Activate with Channels
  - Min Relay Cycle
  - Reset Time Total
  - Name
  - Mode

# ANALOG OUTPUTS (A11-A44) and VIRTUAL OUTPUTS (C1-C8)

**Retransmit (A11-A44)**

HOA Setting  
4 mA Value  
20 mA Value  
Hand Output

☰ · ▲ ▼

Additional settings for Retransmit Mode:  
Error Output  
Reset Time Total  
Input  
Name  
Mode

**Manual Control (A11-A44)**

HOA Setting  
Interlock Channels  
Activate with Channels  
Minimum Relay Cycle

☰ · ▲ ▼

Additional Settings for Manual Control Mode:  
Hand Time Limit  
Reset Time Total  
Name  
Mode

**Prop Control (A11-A44)**

HOA Setting  
Set Point  
Proportional Band  
Min Output

☰ · ▲ ▼

Additional Settings for Proportional Control Mode:  
Max Output  
Output Time Limit  
Reset Output Timeout  
Interlock Channels  
Activate with Channels  
Hand Output  
Hand Time Limit  
Reset Time Total  
Off Mode Output  
Error Output

Input  
Direction  
Name  
Mode

**Mass Balance (A11-A44)**

HOA Setting  
Target  
Pump Rating  
Pump Setting

☰ · ▲ ▼

Additional Settings for Mass Balance Control Mode:  
Specific Gravity  
Output Time Limit  
Reset Output Timeout  
Interlock Channels  
Activate with Channels  
Hand Output  
Hand Time Limit  
Off Mode Output

Error Output  
Reset Time Total  
Flow Input  
Performance Input  
Cycles Input  
Low Cycles Limit  
Name  
Mode

*Only if HVAC mode is disabled*

**PID Control (A11-A44)**

HOA Setting  
Set Point  
Gain  
Proportional Gain

☰ · ▲ ▼

Additional Settings for PID Control Mode:  
Integral Time  
Integral Gain  
Derivative Time  
Derivative Gain  
Reset PID Integral  
Min Output  
Max Output  
Max Rate  
Output Time Limit  
Reset Output Timeout  
Interlock Channels  
Activate with Channels

Hand Output  
Hand Time Limit  
Off Mode Output  
Error Output  
Reset Time Total  
Input  
Direction  
Input Minimum  
Input Maximum  
Gain Form  
Name  
Mode

*Not available for virtual outputs*

**Lag Output (A11-A44)**

HOA Setting  
Lead  
Reset Time Total  
Output Time Limit

☰ · ▲ ▼

Additional settings for Lag Output Mode:  
Reset Output Timeout  
Wear Leveling  
Wear Cycle Time  
Name  
Mode

**Disturbance (A11-A44)**

HOA Setting  
Reset Time Total  
Output Time Limit  
Reset Output Timeout

☰ · ▲ ▼

Additional Settings for Disturbance:  
Min Output  
Max Output  
Interlock Channels  
Activate with Channels  
Hand Output  
Hand Time Limit  
Off Mode Output  
Error Output  
Primary Output

Disturbance Input  
Trigger Input  
Activated  
Trigger Mode  
Name  
Mode

# CONFIG MENU

## HOME SCREEN (example)

▲ Flowswitch (D1) No Flow	
CCond (S11)	3041 µS/cm
Temp (S12)	77.0°F
Flowswitch (D1)	No Flow

Main Menu 09:19:01 14-Mar-2017	
🏠 Inputs	✕ Config
🔊 Outputs	🕒 HOA
⚠ Alarms	📊 Graph
🏠	

Config	
Global Settings	
Security Settings	
Ethernet Settings	
Ethernet Details	
☰	▼

Additional Config Settings:  
 WiFi Settings  
 WiFi Details  
 Remote Communications (Modbus/BacNet)  
 Email Report Settings  
 Display Settings  
 File Utilities  
 Controller Details

Global Settings	
Date	
Time	
Name	
Location	
☰	▼

Additional Global Settings:  
 Global Units  
 Temperature Units  
 Alarm Delay  
 HVAC Modes  
 Language

Security Settings	
Controller Log Out	
Security	
Local Password	
☰	▼

Ethernet Settings	
DHCP Setting	
Controller IP Address	
Network Netmask	
Network Gateway	
☰	▼

Additional Ethernet Settings:  
 DNS Server  
 Web Page Color Scheme  
 Fluent Alarm Delay  
 TCP Timeout  
 Fluent Status  
 LiveConnect Status  
 Update Period  
 Reply Timeout

Ethernet Details	
Alarms	
DHCP Status	
Controller IP Address	
Network Netmask	
☰	▼

Additional Ethernet Details:  
 Network Gateway  
 DNS Server  
 MAC Address  
 Last Fluent Data  
 Last Fluent Config

WiFi Settings	
WiFi Mode	
SSID	
Key	
Gateway Connection	
☰	▼

Additional WiFi Settings:  
 DHCP Setting  
 Controller IP Address  
 Network Netmask  
 Network Gateway  
 DNS Server  
 Ad-Hoc SSID  
 Ad-Hoc Security  
 Ad-Hoc Key  
 SSID Broadcast  
 TCP Timeout  
 Temporary Ad-Hoc  
 Begin/End Temporary  
 Ad-Hoc Mode  
 Ad-Hoc Time Limit

WiFi Details	
Alarms	
Last Fluent Data	
Last Fluent Config	
Live Connect Status	
☰	▼

Additional WiFi Details:  
 WiFi Status  
 Signal Strength  
 RSSI  
 WiFi Channel  
 DHCP Status  
 Controller IP Address  
 Network Netmask  
 Network Gateway  
 Security Protocol  
 DNS Server  
 BSSID/MAC Address  
 FCC ID  
 IC ID

Remote Communications	
Comm Status	
Data Format	
Data Port	
Verbose Logging	
☰	▼

Additional Remote Communications:  
 Device ID  
 Network

Display Settings	
Home 1	
Home 2	
Home 3	
Home 4	
☰	▼

Additional Display Settings:  
 Home 5  
 Home 6  
 Home 7  
 Home 8  
 Adjust Display  
 Key Beep

File Utilities	
File Transfer Status	
Data Log Export	
Periodic Log Export	
Export Event Log	
☰	▼

Additional File Utilities:  
 Export System Log  
 Export User Config File  
 Import User Config File  
 Restore Default Config  
 Software Upgrade

Controller Details	
Controller	
Product Name	
Serial Number	
Controller Board	
☰	▼

Additional Controller Details:  
 Software Version  
 Power Board  
 Sensor Board #1  
 Software Version  
 Sensor Board #2  
 Software Version  
 Sensor Board #3  
 Software Version  
 Sensor Board #4  
 Software Version  
 Last Data Log  
 Digital Inputs  
 Software Version  
 Network  
 Software Version  
 Battery Power  
 Processor Temp  
 Controller Temp 1  
 Controller Temp 2  
 Relay Board Temp  
 Network Temp  
 Processor Temp  
 I/O Card 1 Temp  
 I/O Card 2 Temp  
 I/O Card 3 Temp  
 I/O Card 4 Temp  
 Network Temp  
 DI Temp  
 +12 Volt Supply  
 +5 Volt Supply  
 +3.3 Volt Supply  
 LCD Bias Voltage  
 LCD Supply

Email Report Settings	
Report #1 through #4	
Email Addresses	
Email Server	
SMTP Server	
☰	▼

Report #1-4 Settings:  
 Report Type  
 Email Recipients  
 Repetition (Datalog/Summary Reports/Graph)  
 Reports Per Day (Datalog/Summary Reports/Graph)  
 Day (Datalog/Summary Reports/Graph)  
 Day of Month (Datalog/Summary Reports/Graph)  
 Report Time (Datalog/Summary Reports/Graph)  
 Log Frequency (Datalog Report)  
 Alarm Mode (Alarms Report)  
 Select Alarms (Alarms Report)  
 Alarm Delay (Alarms Report)  
 Attach Summary (Alarms Report)

Additional Email Report Settings:  
 SMTP Port  
 From Address  
 ASMTX Username  
 ASMTX Password  
 Test Report Recipients  
 Send Email Test Report



## **Outputs (see section 5.3)**

### **Program the settings for each output**

The R1 relay output will be displayed. Touch the relay field to get to the Details screen. Touch the Settings icon. If the name of the relay does not describe the control mode desired, touch the Scroll Down icon until Mode field is displayed. Touch the Mode field. Touch the Scroll Down icon until the correct control mode is displayed, then touch the Confirm icon to accept the change. This will bring you back to the Settings screen. Finish the rest of the R1 settings.

If you want the output to be interlocked by a flow switch or by another output being active, enter the Interlock Channels menu and select the input or output channel that will interlock this output.

The default is for the output to be in Off mode, where the output does not react to the settings. Once all settings for that output are complete, enter the HOA Setting menu and change it to Auto.

Repeat for each output.

## **Normal Startup**

Startup is a simple process once your set points are in memory. Simply check your supply of chemicals, turn on the controller, calibrate it if necessary and it will start controlling.

## **4.5 Shut Down**

To shut the controller down, simply turn off the power. Programming remains in memory. It is important that the pH/ORP electrode remains wet. If the shutdown is expected for any longer than a day, and it is possible for the electrode to dry out, remove the electrode from the tee and store it in pH 4 buffer or cooling tower water. Take care to avoid freezing temperatures when storing the pH/ORP electrodes to avoid breakage of the glass.


## **5.0 OPERATION using the touchscreen**

---

These units control continuously while power is applied. Programming is accomplished either via the touchscreen or the optional Ethernet connection. See section 6.0 for Ethernet instructions.

To view the readings of each sensor, or whatever user-defined list of parameters that has been set, touch the Home icon if not already there. The menus for each of these parameters may be accessed directly by touching the parameter.

Keep in mind that even while browsing through menus, the unit is still controlling.

Touch the Main Menu icon  from the home page to access all settings. The menu structure is grouped by alarms, inputs and outputs. Under the Configuration menu will be general settings such as the clock, the language, etc. that do not have an input or output associated with it. Each input has its own menu for calibration and unit selection as needed. Each output has its own setup menu including set points, timer values and operating modes as needed.

### **5.1 Alarms Menu**



Touch the Alarms icon to view a list of active alarms. If there are more than six active alarms, the Page Down icon will be shown; touch this icon to bring up the next page of alarms.

Touch the Main Menu icon to go back to the previous screen.

### **5.2 Inputs Menu**



Touch the Inputs icon to view a list of all sensor and digital inputs. The Page Down icon pages down the list of inputs, the Page Up icon pages up the list of inputs, the Main Menu icon brings back the previous screen.

Touch the input to access that input's details, calibration (if applicable) and settings.

## **Sensor Input Details**

The details for any type of sensor input include the current value read, alarms, the raw (uncalibrated) signal, the sensor type, and the calibration gain and offset. If the sensor has automatic temperature compensation, then the sensor's temperature value and alarms, the temperature resistance value read, and the type of temperature element required are also displayed under a separate sensor input menu.

## **Calibration**

Touch the Calibration icon to calibrate the sensor. Select the calibration to perform: One Point Process, One Point Buffer or Two Point Buffer Calibration. Not all calibration options are available for all types of sensor.

### ***One Point Process Calibration***

#### **New Value**

Enter the actual value of the process as determined by another meter or laboratory analysis and touch Confirm.

#### **Cal Successful or Failed**

If successful, touch Confirm to put the new calibration in memory.

If failed, you may retry the calibration or cancel. Refer to Section 8 to troubleshoot a calibration failure.

### ***One Point Buffer Calibration, Disinfection/Generic Sensor Zero Cal, Conductivity Air Cal***

#### **Cal Disables Control**

Touch Confirm to continue or Cancel to abort

**Buffer Temperature** (only appears if no temperature sensor is detected for sensor types that use automatic temperature compensation)

Enter the temperature of the buffer and touch Confirm.

**Buffer Value** (only appears for One Point Calibration except when automatic buffer recognition is used))

Enter the value of the buffer being used

#### **Rinse Sensor**

Remove the sensor from the process, rinse it off, and place it in the buffer solution (or oxidizer-free water for Zero Cal, or air for the conductivity open air cal). Touch Confirm when ready.

#### **Stabilization**

When the temperature (if applicable) and signal from the sensor is stable, the controller will automatically move to the next step. If they don't stabilize you may manually go to the next step by pressing Confirm.

#### **Cal Successful or Failed**

If successful, touch Confirm to put the new calibration in memory.

If failed, you may retry the calibration or cancel. Refer to Section 8 to troubleshoot a calibration failure.

#### **Resume Control**

Replace the sensor in the process and touch Confirm when ready to resume control.

### ***Two Point Buffer Calibration***

#### **Cal Disables Control**

Touch Confirm to continue or Cancel to abort

**Buffer Temperature** (only appears if no temperature sensor is detected for sensor types that use automatic temperature compensation)

Enter the temperature of the buffer and touch Confirm.

**First Buffer Value (does not appear if automatic buffer recognition is used)**

Enter the value of the buffer being used

#### **Rinse Sensor**

Remove the sensor from the process, rinse it off, and place it in the buffer solution. Touch Confirm when ready.

#### **Stabilization**

When the temperature (if applicable) and signal from the sensor is stable, the controller will automatically move to the next step. If they don't stabilize you may manually go to the next step by touching Confirm.

**Second Buffer Temperature** (only appears if no temperature sensor is detected for sensor types that use automatic temperature compensation)

Enter the temperature of the buffer and press Confirm.

**Second Buffer Value (does not appear if automatic buffer recognition is used )**

Enter the value of the buffer being used

#### **Rinse Electrode**

Remove the sensor from the process, rinse it off, and place it in the buffer solution. Touch Confirm when ready.

#### **Stabilization**

When the temperature (if applicable) and signal from the sensor is stable, the controller will automatically move to the next step. If they don't stabilize you may manually go to the next step by touching Confirm.

#### **Cal Successful or Failed**

If successful, touch Confirm to put the new calibration in memory. The calibration adjusts the offset and the gain (slope) and displays the new values. If failed, you may retry the calibration or cancel. Refer to Section 8 to troubleshoot a calibration failure.

#### **Resume Control**

Replace the sensor in the process and touch Confirm when ready to resume control.

### ***Three Point Buffer Calibration (pH sensors only)***

#### **Cal Disables Control**

Touch Confirm to continue or Cancel to abort

**Buffer Temperature** (only appears if no temperature sensor is detected)

Enter the temperature of the buffer and touch Confirm.

**First Buffer Value** (does not appear if automatic buffer recognition is used)

Enter the value of the buffer being used

#### **Rinse Sensor**

Remove the sensor from the process, rinse it off, and place it in the buffer solution. Touch Confirm when ready.

#### **Stabilization**

When the temperature (if applicable) and signal from the sensor is stable, the controller will automatically move to the next step. If they don't stabilize you may manually go to the next step by touching Confirm.

**Second Buffer Temperature** (only appears if no temperature sensor is detected)

Enter the temperature of the buffer and touch Confirm.

**Second Buffer Value** (does not appear if automatic buffer recognition is used)

Enter the value of the buffer being used

#### **Rinse Electrode**

Remove the sensor from the process, rinse it off, and place it in the buffer solution. Touch Confirm when ready.

#### **Stabilization**

When the temperature (if applicable) and signal from the sensor is stable, the controller will automatically move to the next step. If they don't stabilize you may manually go to the next step by touching Confirm.

**Third Buffer Temperature** (only appears if no temperature sensor is detected)

Enter the temperature of the buffer and touch Confirm.

**Third Buffer Value** (does not appear if automatic buffer recognition is used)

Enter the value of the buffer being used

### **Rinse Electrode**

Remove the sensor from the process, rinse it off, and place it in the buffer solution. Touch Confirm when ready.

### **Stabilization**

When the temperature (if applicable) and signal from the sensor is stable, the controller will automatically move to the next step.

### **Cal Successful or Failed**

If successful, touch Confirm to put the new calibration in memory. The calibration adjusts the offset, gain (slope) and calibration midpoint and displays the new values. If failed, you may retry the calibration or cancel. Refer to Section 7 to troubleshoot a calibration failure.

### **Resume Control**

Replace the sensor in the process and touch Confirm when ready to resume control.

## ***One Point Analog Calibration***

**OK to disable control?** Touch Confirm to continue or Cancel to abort.

### **Input Value**

Enter the mA value that the transmitter will be sending. Touch Confirm to continue or Cancel to abort.

### **Please set input signal to specified value**

Make sure that the transmitter is sending the desired mA signal. Touch Confirm to continue or Cancel to abort.  
Automatic circuit calibration in progress

### **Cal Successful or Failed**

If successful, touch Confirm to save calibration results. The calculated offset will be displayed.  
If failed, you may retry the calibration or cancel. You may also restore calibration to the factory defaults. The calibration will fail if the measured mA is more than 2 mA away from the Input Value entered.

### **Please restore input signal to process value**

Put the transmitter back into normal measurement mode if necessary and touch Confirm when ready to resume control.

## ***Two Point Analog Calibration***

**OK to disable control?** Touch Confirm to continue or Cancel to abort.

### **Input Value**

Enter the mA value that the transmitter will be sending. Touch Confirm to continue or Cancel to abort.

### **Please set input signal to specified value**

Make sure that the transmitter is sending the desired mA signal. Touch Confirm to continue or Cancel to abort.  
Automatic circuit calibration in progress

### **Second Input Value**

Enter the mA value that the transmitter will be sending. Touch Confirm to continue or Cancel to abort.

### **Please set input signal to specified value**

Make sure that the transmitter is sending the desired mA signal. Touch Confirm to continue or Cancel to abort.  
Automatic circuit calibration in progress

### **Cal Successful or Failed**

If successful, touch Confirm to save calibration results. The calculated offset and gain will be displayed.  
If failed, you may retry the calibration or cancel. You may also restore calibration to the factory defaults. The calibration will fail if the offset is more than 2 mA or the gain is not between 0.5 and 2.0.

### **Please restore input signal to process value**

Put the transmitter back into normal measurement mode if necessary and touch Confirm when ready to resume control.

## 5.2.1 Contacting Conductivity

### Settings

Touch the Settings icon to view or change the settings related to the sensor.

<b>Alarms</b>	Low-Low, Low, High and High-High Alarms limits may be set.
<b>Deadband</b>	This is the Alarm Deadband. For example, if the High Alarm is 3000, and the deadband is 10, the alarm will activate at 3001 and deactivate at 2990.
<b>Reset Calibration Values</b>	Enter this menu to reset the sensor calibration back to factory defaults.
<b>Cal Required Alarm</b>	To get an alarm message as a reminder to calibrate the sensor on a regular schedule, enter the number of days between calibrations. Set it to 0 if no reminders are necessary.
<b>Alarm &amp; Datalog Suppression</b>	If any of the relays or digital inputs are selected, any alarms related to this input will be suppressed if the selected relay or digital input is active. At the same time, all datalogs and graphs containing the input will show no data for the duration of the activation.
<b>Smoothing Factor</b>	Increase the smoothing factor percentage to dampen the response to changes. For example, with a 10% smoothing factor, the next reading shown will consist of an average of 10% of the previous value and 90% of the current value.
<b>Default Temp</b>	If the temperature signal is lost at any time, then the controller will use the Default Temp setting for temperature compensation.
<b>Cable Length</b>	The controller automatically compensates for errors in the reading caused by varying the length of the cable.
<b>Gauge</b>	The cable length compensation depends upon the gauge of wire used to extend the cable
<b>Cell Constant</b>	Enter the cell constant of the sensor that is connected to the input.
<b>Temp Compensation</b>	Select between the standard NaCl temperature compensation method or a linear %/degree C method.
<b>Temp Comp Factor</b>	This menu only appears if Linear Temp Comp is selected. Change the %/degree C to match the chemistry being measured. Standard water is 2%.
<b>Units</b>	Select the units of measure for the conductivity.
<b>Name</b>	The name used to identify the sensor may be changed.
<b>Type</b>	Select the type of sensor to be connected.

## 5.2.2 Electrodeless Conductivity

### Settings

Touch the Settings icon to view or change the settings related to the sensor.

<b>Alarms</b>	Low-Low, Low, High and High-High Alarms limits may be set.
<b>Deadband</b>	This is the Alarm Deadband. For example, if the High Alarm is 3000, and the deadband is 10, the alarm will activate at 3000 and deactivate at 2990.
<b>Reset Calibration Values</b>	Enter this menu to reset the sensor calibration back to factory defaults.
<b>Cal Required Alarm</b>	To get an alarm message as a reminder to calibrate the sensor on a regular schedule, enter the number of days between calibrations. Set it to 0 if no reminders are necessary.
<b>Alarm &amp; Datalog Suppression</b>	If any of the relays or digital inputs are selected, any alarms related to this input will be suppressed if the selected relay or digital input is active. At the same time, all datalogs and graphs containing the input will show no data for the duration of the activation.
<b>Smoothing Factor</b>	Increase the smoothing factor percentage to dampen the response to changes. For example, with a 10% smoothing factor, the next reading shown will consist of an average of 10% of the previous value and 90% of the current value.
<b>Default Temp</b>	If the temperature signal is lost at any time, then the controller will use the Default Temp setting for temperature compensation.

<b>Installation Factor</b>	Do not change unless instructed by the factory.
<b>Cable Length</b>	The controller automatically compensates for errors in the reading caused by varying the length of the cable.
<b>Gauge</b>	The cable length compensation depends upon the gauge of wire used to extend the cable
<b>Cell Constant</b>	Do not change unless instructed by the factory. The Walchem sensor is 6.286. Sensors made by others are not supported.
<b>Range</b>	Select the range of conductivity that best matches the conditions the sensor will see.
<b>Temp Compensation</b>	Select between the standard NaCl temperature compensation method or a linear %/degree C method.
<b>Temp Comp Factor</b>	This menu only appears if Linear Temp Comp is selected. Change the %/degree C to match the chemistry being measured. Standard water is 2%.
<b>Units</b>	Select the units of measure for the conductivity.
<b>Name</b>	The name used to identify the sensor may be changed.
<b>Type</b>	Select the type of sensor to be connected.

### 5.2.3 Temperature

#### Settings

Touch the Settings icon to view or change the settings related to the sensor.

<b>Alarms</b>	Low-Low, Low, High and High-High Alarms limits may be set.
<b>Deadband</b>	This is the Alarm Deadband. For example, if the High Alarm is 100, and the deadband is 1, the alarm will activate at 100 and deactivate at 99.
<b>Reset Calibration Values</b>	Enter this menu to reset the sensor calibration back to factory defaults.
<b>Cal Required Alarm</b>	To get an alarm message as a reminder to calibrate the sensor on a regular schedule, enter the number of days between calibrations. Set it to 0 if no reminders are necessary.
<b>Alarm &amp; Datalog Suppression</b>	If any of the relays or digital inputs are selected, any alarms related to this input will be suppressed if the selected relay or digital input is active. At the same time, all datalogs and graphs containing the input will show no data for the duration of the activation.
<b>Smoothing Factor</b>	Increase the smoothing factor percentage to dampen the response to changes. For example, with a 10% smoothing factor, the next reading shown will consist of an average of 10% of the previous value and 90% of the current value.
<b>Name</b>	The name used to identify the sensor may be changed.
<b>Element</b>	Select the specific type of temperature sensor to be connected.

### 5.2.4 pH

#### Settings

Touch the Settings icon to view or change the settings related to the sensor.

<b>Alarms</b>	Low-Low, Low, High and High-High Alarms limits may be set.
<b>Deadband</b>	This is the Alarm Deadband. For example, if the High Alarm is 9.50, and the deadband is 0.05, the alarm will activate at 9.51 and deactivate at 9.45.
<b>Alarm &amp; Datalog Suppression</b>	If any of the relays or digital inputs are selected, any alarms related to this input will be suppressed if the selected relay or digital input is active. At the same time, all datalogs and graphs containing the input will show no data for the duration of the activation.
<b>Smoothing Factor</b>	Increase the smoothing factor percentage to dampen the response to changes. For example, with a 10% smoothing factor, the next reading shown will consist of an average of 10% of the previous value and 90% of the current value.

<b>Reset Calibration Values</b>	Enter this menu to reset the sensor calibration back to factory defaults.
<b>Cal Required Alarm</b>	To get an alarm message as a reminder to calibrate the sensor on a regular schedule, enter the number of days between calibrations. Set it to 0 if no reminders are necessary.
<b>Buffers</b>	Select if calibration buffers will be manually entered, or if they will be automatically detected, and if so, which set of buffers will be used. The choices are Manual Entry, JIS/NIST Standard, DIN Technical, or Traceable 4/7/10.
<b>Default Temp</b>	If the temperature signal is lost at any time, then the controller will use the Default Temp setting for temperature compensation.
<b>Cable Length</b>	The controller automatically compensates for errors in the reading caused by varying the length of the cable.
<b>Gauge</b>	The cable length compensation depends upon the gauge of wire used to extend the cable
<b>Electrode</b>	Select Glass for a standard pH electrode, or Antimony. Antimony pH electrodes have a default slope of 49 mV/pH and an offset of -320 mV at pH 7.
<b>Name</b>	The name used to identify the sensor may be changed.
<b>Type</b>	Select the type of sensor to be connected.

## 5.2.5 ORP

### Settings

Touch the Settings icon to view or change the settings related to the sensor.

<b>Alarms</b>	Low-Low, Low, High and High-High Alarms limits may be set.
<b>Deadband</b>	This is the Alarm Deadband. For example, if the High Alarm is 800, and the deadband is 10, the alarm will activate at 801 and deactivate at 790.
<b>Reset Calibration Values</b>	Enter this menu to reset the sensor calibration back to factory defaults.
<b>Cal Required Alarm</b>	To get an alarm message as a reminder to calibrate the sensor on a regular schedule, enter the number of days between calibrations. Set it to 0 if no reminders are necessary.
<b>Alarm &amp; Datalog Suppression</b>	If any of the relays or digital inputs are selected, any alarms related to this input will be suppressed if the selected relay or digital input is active. At the same time, all datalogs and graphs containing the input will show no data for the duration of the activation.
<b>Smoothing Factor</b>	Increase the smoothing factor percentage to dampen the response to changes. For example, with a 10% smoothing factor, the next reading shown will consist of an average of 10% of the previous value and 90% of the current value.
<b>Cable Length</b>	The controller automatically compensates for errors in the reading caused by varying the length of the cable.
<b>Gauge</b>	The cable length compensation depends upon the gauge of wire used to extend the cable
<b>Name</b>	The name used to identify the sensor may be changed.
<b>Type</b>	Select the type of sensor to be connected.

## 5.2.6 Disinfection

### Settings

Touch the Settings icon to view or change the settings related to the sensor.

<b>Alarms</b>	Low-Low, Low, High and High-High Alarms limits may be set.
<b>Deadband</b>	This is the Alarm Deadband. For example, if the High Alarm is 7.00, and the deadband is 0.1, the alarm will activate at 7.01 and deactivate at 6.90.
<b>Reset Calibration Values</b>	Enter this menu to reset the sensor calibration back to factory defaults.
<b>Cal Required Alarm</b>	To get an alarm message as a reminder to calibrate the sensor on a regular schedule, enter the number of days between calibrations. Set it to 0 if no reminders are necessary.

<b>Alarm &amp; Datalog Suppression</b>	If any of the relays or digital inputs are selected, any alarms related to this input will be suppressed if the selected relay or digital input is active. At the same time, all datalogs and graphs containing the input will show no data for the duration of the activation.
<b>Smoothing Factor</b>	Increase the smoothing factor percentage to dampen the response to changes. For example, with a 10% smoothing factor, the next reading shown will consist of an average of 10% of the previous value and 90% of the current value.
<b>Cable Length</b>	The controller automatically compensates for errors in the reading caused by varying the length of the cable.
<b>Gauge</b>	The cable length compensation depends upon the gauge of wire used to extend the cable
<b>Name</b>	The name used to identify the sensor may be changed.
<b>Sensor</b>	Select the specific type and range of disinfection sensor to be connected.
<b>Type</b>	Select the type of sensor to be connected.

## 5.2.7 Generic Sensor

### Settings

Touch the Settings icon to view or change the settings related to the sensor.

<b>Alarms</b>	Low-Low, Low, High and High-High Alarms limits may be set.
<b>Deadband</b>	This is the Alarm Deadband. For example, if the High Alarm is 7.00, and the deadband is 0.1, the alarm will activate at 7.01 and deactivate at 6.90.
<b>Reset Calibration Values</b>	Enter this menu to reset the sensor calibration back to factory defaults.
<b>Cal Required Alarm</b>	To get an alarm message as a reminder to calibrate the sensor on a regular schedule, enter the number of days between calibrations. Set it to 0 if no reminders are necessary.
<b>Alarm &amp; Datalog Suppression</b>	If any of the relays or digital inputs are selected, any alarms related to this input will be suppressed if the selected relay or digital input is active. At the same time, all datalogs and graphs containing the input will show no data for the duration of the activation.
<b>Sensor Slope</b>	Enter the slope of sensor in mV/Units (if Electrode selection is Linear) or mV/Decade (if Electrode selection is Ion Selective).
<b>Sensor Offset</b>	Only appears if the Electrode selection is Linear. Enter the offset of the sensor in mV if 0 mV is not equal to 0 units. <b>For Ion Selective Electrodes, the Sensor Offset is not calculated until the first calibration is performed, and the sensor will read Zero until a calibration has been successfully completed!</b>
<b>Low Range</b>	Enter the low end of the range of the sensor
<b>High Range</b>	Enter the high end of the range of the sensor
<b>Smoothing Factor</b>	Increase the smoothing factor percentage to dampen the response to changes. For example, with a 10% smoothing factor, the next reading shown will consist of an average of 10% of the previous value and 90% of the current value.
<b>Cable Length</b>	The controller automatically compensates for errors in the reading caused by varying the length of the cable.
<b>Gauge</b>	The cable length compensation depends upon the gauge of wire used to extend the cable
<b>Units</b>	Type in the units of measure for the input, for example, ppm.
<b>Electrode</b>	Select the type of electrode to be connected. Select Linear if the sensor slope is a linear voltage per Units. Select Ion Selective if the electrode voltage output is logarithmic, defined as “mV/decade”.
<b>Name</b>	The name used to identify the sensor may be changed.
<b>Type</b>	Select the type of sensor to be connected.



## 5.2.8 Corrosion Input

ONLY AVAILABLE IF A CORROSION INPUT BOARD IS INSTALLED

### Input Details

The details for this type of input include the current corrosion rate, alarms, status, current stage in the measurement cycle, the elapsed time in the current cycle, the raw (uncalibrated) corrosion rate, the number of days in service of the electrodes, the calibration offset, the date of last calibration, and the type of input.

### Settings

Touch the Settings icon to view or change the settings related to the sensor.

<b>Alarms</b>	Low-Low, Low, High and High-High Alarms limits may be set.
<b>Deadband</b>	This is the Alarm Deadband. For example, if the High Alarm is 10, and the deadband is 0.1, the alarm will activate at 10.01 and deactivate at 9.9.
<b>Replace Corrosion Electrode</b>	Used to reset the timers for both the “Electrode Alarm” and the “Stabilization Time”.
<b>Stabilization time</b>	Provides a control lock-out during the initial period of high readings when the electrode is changed. Set to 0 hours to disable.
<b>Electrode Alarm</b>	Set a reminder, in days, for when to replace the electrode tips.
<b>Reset Calibration Values</b>	Enter this menu to reset the sensor calibration back to factory defaults.
<b>Cal Required Alarm</b>	To get an alarm message as a reminder to calibrate the sensor on a regular schedule, enter the number of days between calibrations. Set it to 0 if no reminders are necessary.
<b>Alarm &amp; Datalog Suppression</b>	If any of the relays or digital inputs are selected, any alarms related to this input will be suppressed if the selected relay or digital input is active. At the same time, all datalogs and graphs containing the input will show no data for the duration of the activation.
<b>Smoothing Factor</b>	Increase the smoothing factor percentage to dampen the response to changes. For example, with a 10% smoothing factor, the next reading shown will consist of an average of 10% of the previous value and 90% of the current value.
<b>Alloy Multiplier</b>	Enter the multiplier that matches the metallurgy of the electrodes connected to the sensor. Refer to the chart below.
<b>Cycle Time</b>	Select the length of the cycle time to be used. The longer cycle times provide more accurate readings but decrease the speed of response.
<b>Range</b>	Select the expected range of the corrosion rate.
<b>Units</b>	Select the units of measure for the corrosion.
<b>Name</b>	The name used to identify the sensor may be changed.
<b>Type</b>	Select the type of sensor to be connected.

### Alloy Multipliers

These values are based on using standard corrosion electrodes with 5 cm<sup>2</sup> surface area.

Material	Multiplier	UNS Code
Carbon Steel	1.00	K03005
Copper 110 ETP	2.00	C11000
Admiralty Brass	1.67	C44300
Aluminum 1100	0.94	A91100
Aluminum 2024	0.88	A92024
Phosphorized Admiralty Brass	1.68	C44500
Aluminum Silicon Bronze	1.48	C64200

Aluminum Brass	1.62	C68700
Copper/Nickel 90/10	1.80	C70610
Copper/Nickel 70/30	1.50	C71500
AISI 4130 Alloy Steel	1.00	G41300
Lead	2.57	L50045
Monel 400 Nickel	1.13	N04400
Monel K500 Nickel	1.04	N05500
Hastelloy C22	0.85	N06022
Inconel 600 Nickel	0.95	N06600
Incoloy Alloy 20	0.98	N08020
Incoloy Alloy 800	0.89	N08800
Incoloy Alloy 825	0.88	N08825
Hastelloy C276	0.86	N10276
Titanium Grade 2	0.75	R50400
304 Stainless Steel	0.89	S30400
316 Stainless Steel	0.90	S31600
2205 Duplex Stainless Steel	0.89	S31803
2507 Super Duplex Stainless Steel	0.88	S32750
Zinc	1.29	Z17001

## 5.2.9 Corrosion Imbalance Input

ONLY AVAILABLE IF A CORROSION INPUT BOARD IS INSTALLED

### Input Details

The details for this type of input include the current corrosion imbalance value, alarms, status, current stage in the measurement cycle, the elapsed time in the current cycle, the ratio of the current imbalance value to the current corrosion rate, the calibration offset, the date of last calibration, and the type of input.

### Settings

Touch the Settings icon to view or change the settings related to the sensor.

<b>Alarms</b>	Low-Low, Low, High and High-High Alarms limits may be set.
<b>Deadband</b>	This is the Alarm Deadband. For example, if the High Alarm is 10, and the deadband is 0.1, the alarm will activate at 10.01 and deactivate at 9.9.
<b>Reset Calibration Values</b>	Enter this menu to reset the sensor calibration back to factory defaults.
<b>Cal Required Alarm</b>	To get an alarm message as a reminder to calibrate the sensor on a regular schedule, enter the number of days between calibrations. Set it to 0 if no reminders are necessary.
<b>Alarm &amp; Datalog Suppression</b>	If any of the relays or digital inputs are selected, any alarms related to this input will be suppressed if the selected relay or digital input is active. At the same time, all datalogs and graphs containing the input will show no data for the duration of the activation.
<b>Name</b>	The name used to identify the sensor may be changed.
<b>Type</b>	Select the type of sensor to be connected.

## 5.2.10 Transmitter Input and AI Monitor Input

Select AI monitor if the device connected can be calibrated on its own and the OnGuard™ P900 series calibration will only be in units of mA. Select Transmitter if the device connected cannot be calibrated on its own and the OnGuard™ P900 series will be used to calibrate in engineering units of measure.

### Settings

Touch the Settings icon to view or change the settings related to the sensor.

<b>Alarms</b>	Low-Low, Low, High and High-High Alarms limits may be set.
<b>Deadband</b>	This is the Alarm Deadband. For example, if the High Alarm is 7.00, and the deadband is 0.1, the alarm will activate at 7.01 and deactivate at 6.90.
<b>Transmitter</b>	Select the type of transmitter connected (2-wire loop powered, 2-wire self-powered, 3-wire, or 4-wire).
<b>Reset Calibration Values</b>	Enter this menu to reset the sensor calibration back to factory defaults.
<b>Cal Required Alarm</b>	To get an alarm message as a reminder to calibrate the sensor on a regular schedule, enter the number of days between calibrations. Set it to 0 if no reminders are necessary.
<b>Alarm &amp; Datalog Suppression</b>	If any of the relays or digital inputs are selected, any alarms related to this input will be suppressed if the selected relay or digital input is active. At the same time, all datalogs and graphs containing the input will show no data for the duration of the activation.
<b>Smoothing Factor</b>	Increase the smoothing factor percentage to dampen the response to changes. For example, with a 10% smoothing factor, the next reading shown will consist of an average of 10% of the previous value and 90% of the current value.
<b>4 mA Value</b>	Enter the value that corresponds to a 4 mA output signal from the transmitter.
<b>20 mA Value</b>	Enter the value that corresponds to a 20 mA output signal from the transmitter.
<b>Units</b>	Select the units of measure for the transmitter.
<b>Name</b>	The name used to identify the transmitter may be changed.
<b>Type</b>	Select the type of sensor to be connected. The choice of AI Monitor and Transmitter is only available if a 4-20mA type sensor card is installed.

## 5.2.11 Fluorometer Input

### Settings

Touch the Settings icon to view or change the settings related to the sensor.

<b>Alarms</b>	Low-Low, Low, High and High-High Alarms limits may be set.
<b>Deadband</b>	This is the Alarm Deadband. For example, if the High Alarm is 7.00, and the deadband is 0.1, the alarm will activate at 7.01 and deactivate at 6.90.
<b>Transmitter</b>	Select the type of transmitter connected (2-wire loop powered, 2-wire self-powered, 3-wire, or 4-wire).
<b>Reset Calibration Values</b>	Enter this menu to reset the sensor calibration back to factory defaults.
<b>Cal Required Alarm</b>	To get an alarm message as a reminder to calibrate the sensor on a regular schedule, enter the number of days between calibrations. Set it to 0 if no reminders are necessary.
<b>Alarm &amp; Datalog Suppression</b>	If any of the relays or digital inputs are selected, any alarms related to this input will be suppressed if the selected relay or digital input is active. At the same time, all datalogs and graphs containing the input will show no data for the duration of the activation.
<b>Smoothing Factor</b>	Increase the smoothing factor percentage to dampen the response to changes. For example, with a 10% smoothing factor, the next reading shown will consist of an average of 10% of the previous value and 90% of the current value.
<b>Max Sensor Range</b>	Enter the value of the ppb of dye at which the sensor transmits 20 mA.

<b>Dye/Product Ratio</b>	Enter the value for the ratio of ppb of dye to ppm of inhibitor that is in the inhibitor product being fed.
<b>Name</b>	The name used to identify the transmitter may be changed.
<b>Type</b>	Select the type of sensor to be connected. The choice of Analog Input is only available if that type of sensor card is installed.

## 5.2.12 Analog Flowmeter Input

Settings 

Touch the Settings icon to view or change the settings related to the sensor.

<b>Alarms</b>	Low-Low, Low, High and High-High Alarms limits may be set.
<b>Deadband</b>	This is the Alarm Deadband. For example, if the High Alarm is 7.00, and the deadband is 0.1, the alarm will activate at 7.01 and deactivate at 6.90.
<b>Totalizer Alarm</b>	Enter the high limit on the total volume of water accumulated above which an alarm will be activated.
<b>Reset Flow Total</b>	Enter this menu to reset the accumulated flow total to 0. Touch Confirm to accept, Cancel to leave the total at the previous value and go back.
<b>Set Flow Total</b>	This menu is used to set the total volume stored in the controller to match the register on the flow meter. Enter the desired value.
<b>Scheduled Reset</b>	Choose to automatically reset the flow total, and if so, Daily, Monthly or Annually.
<b>Reset Calibration Values</b>	Enter this menu to reset the sensor calibration back to factory defaults.
<b>Cal Required Alarm</b>	To get an alarm message as a reminder to calibrate the sensor on a regular schedule, enter the number of days between calibrations. Set it to 0 if no reminders are necessary.
<b>Alarm &amp; Datalog Suppression</b>	If any of the relays or digital inputs are selected, any alarms related to this input will be suppressed if the selected relay or digital input is active. At the same time, all datalogs and graphs containing the input will show no data for the duration of the activation.
<b>Smoothing Factor</b>	Increase the smoothing factor percentage to dampen the response to changes. For example, with a 10% smoothing factor, the next reading shown will consist of an average of 10% of the previous value and 90% of the current value.
<b>Transmitter</b>	Select the type of transmitter connected (2-wire loop powered, 2-wire self-powered, 3-wire, or 4-wire).
<b>Flow Units</b>	Select the units of measure for the water volume, between gallons, liters, cubic meters and million of gallons (MG).
<b>Rate Units</b>	Select the units of measure for the flow rate time base.
<b>Flowmeter Max</b>	Enter the flow rate at which the meter outputs a 20 mA signal.
<b>Input Filter</b>	Enter the mA below which the flow rate will be considered 0. Typically any meter output below 4.02 mA is actually 0 flow.
<b>Name</b>	The name used to identify the sensor may be changed.
<b>Type</b>	Select the type of sensor to be connected.

## 5.2.13 Analog Tank Level Input

Settings 

Touch the Settings icon to view or change the settings related to the sensor.

<b>Alarms</b>	Low-Low, Low, High and High-High Alarms limits may be set.
<b>Deadband</b>	This is the Alarm Deadband. For example, if the High Alarm is 7.00, and the deadband is 0.1, the alarm will activate at 7.01 and deactivate at 6.90.
<b>Reset Calibration Values</b>	Enter this menu to reset the sensor calibration back to factory defaults.

<b>Alarm &amp; Datalog Suppression</b>	If any of the relays or digital inputs are selected, any alarms related to this input will be suppressed if the selected relay or digital input is active. At the same time, all datalogs and graphs containing the input will show no data for the duration of the activation.
<b>Units</b>	Enter the units of measure for the transmitter.
<b>Tank Capacity</b>	Enter the capacity of the tank when full in the units of measure entered above.
<b>Empty At</b>	Enter the mA output of the level sensor when the tank is empty.
<b>Full At</b>	Enter the mA output of the level sensor when the tank is full.
<b>Smoothing Factor</b>	Increase the smoothing factor percentage to dampen the re-sponse to changes. For example, with a 10% smoothing factor, the next reading shown will consist of an average of 10% of the previous value and 90% of the current value.
<b>Transmitter</b>	Select the type of transmitter connected (2-wire loop powered, 2-wire self-powered, 3-wire, or 4-wire).
<b>Name</b>	The name used to identify the transmitter may be changed.
<b>Type</b>	Select the type of sensor to be connected.

## 5.2.14 DI State

### Input Details

The details for this type of input include the current state with a custom message for open versus closed, alarms, the status of the interlock, and the current type of input setting.

### Settings

Touch the Settings icon to view or change the settings related to the sensor.

<b>Open Message</b>	The words used to describe the switch state may be customized.
<b>Closed Message</b>	The words used to describe the switch state may be customized.
<b>Interlock</b>	Choose whether the input should be in the interlocked state when the switch is either open or closed.
<b>Alarm</b>	Choose if an alarm should be generated when the switch is open, or closed, or if no alarm should ever be generated.
<b>Alarm &amp; Datalog Suppression</b>	If any of the relays or digital inputs are selected, any alarms related to this input will be suppressed if the selected relay or digital input is active. At the same time, all datalogs and graphs containing the input will show no data for the duration of the activation.
<b>Total Time</b>	Choose to totalize the amount of time that the switch has been open or closed. This will be displayed on the input details screen.
<b>Reset Total Time</b>	Enter this menu to reset the accumulated time to zero. Touch Confirm to accept, Cancel to leave the total at the previous value and go back.
<b>Name</b>	The name used to identify the switch may be changed.
<b>Type</b>	Select the type of sensor to be connected to the digital input channel.

## 5.2.15 Flow Meter, Contactor Type

### Input Details

The details for this type of input include the total volume accumulated through the flow meter, alarms, and the current type of input setting.

### Settings

Touch the Settings icon to view or change the settings related to the sensor.

<b>Alarms</b>	Low and High Alarm limits may be set.
---------------	---------------------------------------

<b>Deadband</b>	This is the Alarm Deadband. For example, if the High Alarm is 100, and the deadband is 1, the alarm will activate at 100 and deactivate at 99
<b>Totalizer Alarm</b>	Enter the high limit on the total volume of water accumulated above which an alarm will be activated.
<b>Alarm &amp; Datalog Suppression</b>	If any of the relays or digital inputs are selected, any alarms related to this input will be suppressed if the selected relay or digital input is active. At the same time, all datalogs and graphs containing the input will show no data for the duration of the activation.
<b>Reset Flow Total</b>	Enter this menu to reset the accumulated flow total to 0. Touch Confirm to accept, Cancel to leave the total at the previous value and go back.
<b>Set Flow Total</b>	This menu is used to set the total volume stored in the controller to match the register on the flow meter. Enter the desired value.
<b>Scheduled Reset</b>	Choose to automatically reset the flow total, and if so, Daily, Monthly or Annually.
<b>Volume/Contact</b>	Enter the volume of water that needs to go through the flow meter in order to generate a contact closure.
<b>Flow Units</b>	Select the units of measure for the water volume.
<b>Name</b>	The name used to identify the sensor may be changed.
<b>Type</b>	Select the type of sensor to be connected to the digital input channel.

## 5.2.16 Flow Meter, Paddlewheel Type

### Input Details

The details for this type of input include the current flow rate, total volume accumulated through the flow meter, alarms, and the current type of input setting.

### Settings

Touch the Settings icon to view or change the settings related to the sensor.

<b>Alarms</b>	Low and High Alarm limits may be set.
<b>Alarm &amp; Datalog Suppression</b>	If any of the relays or digital inputs are selected, any alarms related to this input will be suppressed if the selected relay or digital input is active. At the same time, all datalogs and graphs containing the input will show no data for the duration of the activation.
<b>Deadband</b>	This is the Alarm Deadband. For example, if the High Alarm is 100, and the deadband is 1, the alarm will activate at 100 and deactivate at 99.
<b>Totalizer Alarm</b>	Enter the high limit on the total volume of water accumulated above which an alarm will be activated.
<b>Reset Flow Total</b>	Enter this menu to reset the accumulated flow total to 0. Touch Confirm to accept, Cancel to leave the total at the previous value and go back.
<b>Set Flow Total</b>	This menu is used to set the total volume stored in the controller to match the register on the flow meter. Enter the desired value.
<b>Scheduled Reset</b>	Choose to automatically reset the flow total, and if so, Daily, Monthly or Annually.
<b>K Factor</b>	Enter the pulses generated by the paddlewheel per unit volume of water.
<b>Flow Units</b>	Select the units of measure for the water volume.
<b>Rate Units</b>	Select the units of measure for the flow rate time base.
<b>Smoothing Factor</b>	Increase the smoothing factor percentage to dampen the response to changes. For example, with a 10% smoothing factor, the next reading shown will consist of an average of 10% of the previous value and 90% of the current value.
<b>Name</b>	The name used to identify the sensor may be changed.
<b>Type</b>	Select the type of sensor to be connected to the digital input channel.

## 5.2.17 Feed Monitor

The Feed Monitor Digital Input type performs the following functions:

- Monitors a pulse signal from a pump (Iwaki PosiFlow, Tacmina Flow Checker, LMI Digital Pulse, etc)
- Totalizes the chemical feed and calculates the current flow rate
- Activates a Total Alarm if the feed exceeds a specified limit
- Activates a Flow verify alarm if the control output is ON and the feed monitor does not record any pulses within a specified period of time.

Each Feed Monitor input can be linked to any type of output channel (powered relay, dry contact relay, solid state relay, or analog 4-20 mA) to validate chemical feed from any type of pump.

### Total Alarm

The OnGuard™ P900 series monitors the total feed and activates a Total Alarm if the value exceeds the Totalizer Alarm set point. When used in conjunction with Scheduled Reset selections (Daily, Monthly, or Annually), this alarm can be used to alert users to situations where excess chemical product is used and/or to discontinue chemical feed if the amount exceeds the set point during the specified time period.

While a Total Alarm is active, the linked pump will be controlled based on the Total Alarm Mode setting:

<b>Interlock</b>	The output will be OFF while the alarm is active.
<b>Maintain</b>	The alarm condition has no effect on output control.

### Flow Verify Alarm

The OnGuard™ P900 series monitors the status or current percent output of the channel linked to the feed monitor to determine if a Flow Verify alarm should be activated.

The *Flow Alarm Delay* setting (MM:SS) contains the time to trigger the alarm if the output is activated and no pulses are registered. To avoid nuisance alarms at very low flow rates, if the linked output is a solid state relay (set with a pulse proportional or PID control mode) or an analog 4-20 mA output, the alarm will only be activated if no input pulses are monitored while the output is set to greater than a specified Dead Band (%).

The *Flow Alarm Clear* setting is the number of pulses that must be registered to verify that pump operation is restored and clear the Flow Verify alarm. During Flow Verify alarm conditions, the count of pulses registered will be reset to zero if no single pulses occur during the Flow Alarm Delay time period. In this manner, random single pulses spread over a long time period will not accumulate and result in a Flow Verify alarm being cleared before product feed is actually restored.

If desired, a user can configure the feed monitor to attempt to reprime the pump when a Flow Verify alarm first is activated.

The *Reprime Time* (MM:SS) specifies the amount of time that the output should be energized after the initiation of a Flow Verify alarm. If the linked output is a solid state relay (set to a pulse proportional or PID control mode) or an analog 4-20 mA output, the output will be set to the Max Output percent during the reprime event. If the Flow Verify alarm is cleared during the reprime event (because the specified number of pulses was registered), the reprime event will be immediately ended and normal control of the output channel will be restored.

While a Flow Verify alarm is active, the linked pump will be controlled based on the Flow Alarm Mode setting:

<b>Disabled</b>	<i>Flow Verify</i> alarms are not monitored, no change in output control.
<b>Interlock</b>	The output will be forced OFF while the alarm is active.(except during the reprime event)
<b>Maintain</b>	The alarm condition has no effect on output control. (except during the reprime event)

If a *Flow Verify* alarm is active and *Interlock* is selected, the output to the pump will be turned off after the specified Reprime Time and only operator actions can restore normal control operations. In most cases, action will be taken to manually reprime the pump, refill the chemical tank, etc. and the output will be put into Hand mode to confirm proper operation of the pump. When the Feed Monitor registers sufficient pulses, the Flow Verify alarm will clear and the pump output can be put back into Auto Mode.

If both *Total Alarm* and *Flow Verify* alarms are active simultaneously, an Interlock selection for either mode setting will take precedence for pump control. Automatic output control will continue despite the alarm conditions only if Maintain is selected for both mode settings.

## Interlocking or Activating any Control Output with a Feed Monitor Input

Digital Input channels are available for selection as Interlock Channels or Activate With Channels by any output. If a Feed Monitor is selected in this manner, the Digital Input will trigger that action if any alarm (Flow Verify, Total Alarm, or Range Alarm) is currently active.

### Input Details

The details for this type of input include the current flow rate of chemical feed, the total volume fed since the last reset, alarms, the status of the output linked to the input, the date and time of the last total reset, and the current type of input setting.

### Settings

Touch the Settings icon to view or change the settings related to the sensor.

<b>Totalizer Alarm</b>	A high limit on the total accumulated volume of chemical fed may be set, to trigger a Total Alarm.
<b>Reset Flow Total</b>	Enter this menu to reset the accumulated flow total to 0. Touch Confirm to accept, Cancel to leave the total at the previous value and go back.
<b>Set Flow Total</b>	This menu is used to set the total accumulated volume stored in the controller to match a specified volume.
<b>Scheduled Reset</b>	Choose to automatically reset the flow total, and if so, Daily, Monthly or Annually
<b>Total Alarm Mode</b>	Choose to Interlock or Maintain the control of the linked pump while the Total Alarm is active.
<b>Flow Alarm Mode</b>	Choose to Interlock or Maintain the control of the linked pump while a Flow Verify alarm is active. Choose Disable to monitor flow rate and accumulate total without any flow alarms.
<b>Flow Alarm Delay</b>	Time (MM:SS) that will trigger a Flow Verify alarm if the output is activated and no pulses are registered.
<b>Flow Alarm Clear</b>	Enter the number of contacts that must be registered to clear a Flow Verify alarm.
<b>Dead band</b>	Enter the percent output above which the pump is considered On for monitoring of Flow Verify alarms. This setting is only available if the linked Output is a solid state (pulsing) relay or analog (4-20 mA) output.
<b>Reprime Time</b>	Time (MM:SS) that the output should be energized for the reprime event.
<b>Volume/Contact</b>	Enter the volume, in ml, of chemical delivered for each pulse of the feed monitoring device.
<b>Flow Units</b>	Select the units of measure for the accumulated feed total.
<b>Rate Units</b>	Select the units of measure for the feed flow rate time base.
<b>Smoothing Factor</b>	Increase the smoothing factor percentage to dampen the response to changes in the flowrate. For example, with a 10% smoothing factor, the next reading shown will consist of an average of 10% of the previous value and 90% of the current value.
<b>Output</b>	Select the relay or analog (4-20 mA) output channel controlling the pump which will be monitored by this feed monitor input.
<b>Name</b>	The name used to identify the sensor may be changed.
<b>Type</b>	Select the type of sensor to be connected to the digital input channel

## 5.2.18 DI Counter Input

ONLY AVAILABLE IF HVAC MODES ARE DISABLED IN CONFIG MENU – GLOBAL SETTINGS

A digital input counter input is used to count contacts from a digital input, totalize the number of contacts, and monitor or control on the rate of contacts.

### Input Details

The details for this type of input include the current rate, total contacts counted (in user defined units), date and



time of last total reset, alarms, and the current type of input setting.

## Settings

Touch the Settings icon to view or change the settings related to the virtual input.

<b>Alarms</b>	Low and High Alarm limits may be set.
<b>Deadband</b>	This is the Alarm Deadband. For example, if the High Alarm is 100, and the deadband is 1, the alarm will activate at 100 and deactivate at 99
<b>Totalizer Alarm</b>	A high limit on the total number of contact closures accumulated may be set.
<b>Alarm &amp; Datalog Suppression</b>	If any of the relays or digital inputs are selected, any alarms related to this input will be suppressed if the selected relay or digital input is active. At the same time, all datalogs and graphs containing the input will show no data for the duration of the activation.
<b>Reset Total</b>	Enter this menu to reset the accumulated total to 0. Touch Confirm to accept, or Cancel to leave the total at the previous value and go back.
<b>Set Total</b>	This menu is used to set the total number of contact closures stored in the controller a certain value.
<b>Scheduled Reset</b>	Choose to automatically reset the flow total, and if so, Daily, Monthly or Annually.
<b>Units</b>	Type in the units of measure for the what the contacts represent (widgets, etc.)
<b>Rate Units</b>	Select the units of measure for the rate time base (widgets per second, minute, hour, day).
<b>Units per Pulse</b>	Enter the number of units represented by one pulse.
<b>Smoothing Factor</b>	Increase the smoothing factor percentage to dampen the response to changes. For example, with a 10% smoothing factor, the next rate reading shown will consist of an average of 10% of the previous value and 90% of the current value.
<b>Name</b>	The name used to identify the sensor may be changed.
<b>Type</b>	Select the type of sensor to be connected to the digital input channel.

### 5.2.19 Remote Modbus DI State

ONLY AVAILABLE IF A MODBUS KEY FILE HAS BEEN IMPORTED AND THE COMM STATUS IN THE REMOTE COMMUNICATIONS MENU HAS BEEN SET TO MODBUS

The Remote Modbus DI State input is used to simulate a switch closure by obtaining the open or closed state information from a Modbus application via Modbus TCP. This information can be used to Interlock or activate a control output in exactly the same way as a physical switch. This virtual input type however uses up an actual input channel.

#### Input Details

The details for this type of input include the current state with a custom message for open versus closed, alarms, the status of the interlock, date/time of the last update, cycle time, 24-hour time, total time, date/time of last total time reset and the current type of input setting.

## Settings

Touch the Settings icon to view or change the settings related to the sensor.

<b>Open Message</b>	The words used to describe the virtual switch-open state may be customized.
<b>Closed Message</b>	The words used to describe the virtual switch-closed state may be customized.
<b>Interlock</b>	Choose whether the input should be in the interlocked state when the virtual switch is either open or closed.

<b>Alarm</b>	Choose if an alarm should be generated when the virtual switch is open, or closed, or if no alarm should ever be generated.
<b>Modbus Mode</b>	Select Server Mode is the Modbus application will write the value to the input on its own schedule. Select Client if the controller will ask the Modbus application for the latest value.
<b>Remote Device IP</b>	Client mode only. Enter the IP address of the device that will provide the Modbus data.
<b>Data Port</b>	Client mode only. Enter the data port to be used by the Modbus TCP connection.
<b>Reply Timeout</b>	Client mode only. Enter the number of seconds to wait before retrying if no data is received.
<b>Function</b>	Client mode only. Select the Modbus function that the controller will use to read data.
<b>Remote Register</b>	Client mode only. Enter the register that contains the desired data.
<b>Update Period</b>	Client mode only. Enter the frequency that the controller will request new data.
<b>Timeout Alarm Delay</b>	Enter the time that will trigger an Update Timeout alarm if no new data has been received from the Modbus application.
<b>Total Time</b>	Choose to totalize the amount of time that the virtual switch has been open or closed. This will be displayed on the input details screen.
<b>Reset Time Total</b>	Enter this menu to reset the accumulated time to zero. Touch Confirm to accept, Cancel to leave the total at the previous value and go back.
<b>Alarm &amp; Datalog Suppression</b>	If any of the relays or digital inputs are selected, any alarms related to this input will be suppressed if the selected relay or digital input is active. At the same time, all datalogs and graphs containing the input will show no data for the duration of the activation.
<b>Name</b>	The name used to identify the virtual switch may be changed.
<b>Type</b>	Select the type of sensor to be connected to the digital input channel.

### 5.2.20 Virtual Input – Calculation

A Calculation type Virtual Input is not a physical sensor; it is a value that is calculated from two physical sensor inputs. The analog values that can be used for each type of calculation are selected from a List of all defined sensor inputs, analog inputs, flowmeter rates, the other virtual input, solid state relay %, and analog output %.

Calculation modes are:

- **Difference** (Input - Input 2)
- **Ratio** (Input / Input 2)
  - This selection could be used to calculate Cycles of Concentration in HVAC applications, for example
- **Total** (Input + Input 2)
- **% Difference** [(Input - Input 2) / Input]
  - This selection could be used to calculate % Rejection in RO applications, for example

#### Virtual Input Details

The details for any type of virtual input include the current value calculated, alarms, the status, and the input type.

#### Settings

Touch the Settings icon to view or change the settings related to the virtual input.

<b>Alarms</b>	Low-Low, Low, High and High-High Alarms limits may be set.
<b>Deadband</b>	This is the Alarm Deadband. For example, if the High Alarm is 7.00, and the deadband is 0.1, the alarm will activate at 7.01 and deactivate at 6.90.
<b>Input</b>	Select the physical input or select Constant, whose value will be used in the calculation shown above as the Input in the formula.

<b>Constant</b>	Only appears if the Input selection is Constant. Enter the value.
<b>Input 2</b>	Select the physical input or select Constant, whose value will be used in the calculation shown above as the Input 2 in the formula.
<b>Constant 2</b>	Only appears if the Input 2 selection is Constant. Enter the value.
<b>Calculation Mode</b>	Select a calculation mode from the list.
<b>Alarm &amp; Datalog Suppression</b>	If any of the relays or digital inputs are selected, any alarms related to this input will be suppressed if the selected relay or digital input is active. At the same time, all datalogs and graphs containing the input will show no data for the duration of the activation.
<b>Low Range</b>	Set the low end of the normal range for the calculated value. A value below this will trigger a Range Alarm and deactivate any control output using the virtual input.
<b>High Range</b>	Set the high end of the normal range for the calculated value. A value above this will trigger a Range Alarm and deactivate any control output using the virtual input.
<b>Smoothing Factor</b>	Increase the smoothing factor percentage to dampen the response to changes. For example, with a 10% smoothing factor, the next reading shown will consist of an average of 10% of the previous value and 90% of the current value.
<b>Name</b>	The name used to identify the input may be changed.
<b>Type</b>	Select the type of input; either Calculation, Redundant, Raw Value, Disturbance, or Not Used.

### 5.2.21 Virtual Input – Redundant

A Redundant type Virtual Input is not a physical sensor; it is a value that is calculated from two physical sensor inputs. The redundant sensor algorithm compares the readings from two sensors, and chooses which sensor to use. The value of the virtual input is the value of the sensor chosen by this comparison.

If the difference between the two exceeds a programmable amount, a deviation alarm is set, but control continues. If one of the sensors goes into a range error or a fault alarm, the other sensor will take over. If both sensors give invalid readings, an input alarm is set and any outputs using the virtual input for control are disabled.

The analog values that can be used for each type of calculation are selected from a List of all defined sensor inputs and analog inputs.

There are three modes:

- Primary/Backup – The primary sensor (selected as the Input) value, as opposed to the backup sensor (selected as Input 2) value, is chosen as the virtual input value, assuming it has a valid reading.
- Minimum Value – The sensor that has the lower reading of the two sensors is chosen as the virtual input value. This makes sense if a failing sensor normally drifts high.
- Maximum Value – The sensor that has the higher reading of the two sensors is chosen as the virtual input value. This makes sense if a failing sensor normally drifts low.

#### Virtual Input Details

The details for a virtual input include the current difference calculated, the current values of the inputs used in the calculation, alarms, the status, and the input type.

#### Settings

Touch the Settings icon to view or change the settings related to the virtual input.

<b>Deviation Alarm</b>	Enter the value for the difference between the two input readings above which the deviation alarm will trigger.
------------------------	---

<b>Deadband</b>	This is the Alarm Deadband. For example, if the Deviation Alarm is 1.00, and the deadband is 0.1, the alarm will activate if the sensor readings are 1.01 units apart, and deactivate at 0.89 units apart.
<b>Alarm &amp; Datalog Suppression</b>	If any of the relays or digital inputs are selected, any alarms related to this input will be suppressed if the selected relay or digital input is active. At the same time, all datalogs and graphs containing the input will show no data for the duration of the activation.
<b>Mode</b>	Select which mode for determining the value for the virtual sensor input.
<b>Input</b>	Select the physical input for the primary sensor.
<b>Input 2</b>	Select the physical input for the backup sensor.
<b>Name</b>	The name used to identify the input may be changed.
<b>Type</b>	Select the type of input; either Calculation, Redundant, Raw Value, Disturbance, or Not Used.

### 5.2.22 Virtual Input – Raw Value

A Raw Value type Virtual Input is not a physical input. The value of the virtual input comes from the unmanipulated signal from a real sensor.

- non-temperature compensated  $\mu\text{S}/\text{cm}$
- mV for pH, ORP, Disinfection, Generic
- mA for analog inputs
- ohms for temperature

#### Virtual Input Details

The details for a virtual input include the current raw value of the real input used, alarms, the status, and the input type.

#### Settings

Touch the Settings icon to view or change the settings related to the virtual input.

<b>Alarms</b>	Low-Low, Low, High and High-High Alarms limits may be set.
<b>Deadband</b>	This is the Alarm Deadband. For example, if the High Alarm is 7.00, and the deadband is 0.10, the alarm will activate at 7.01 and deactivate at 6.90.
<b>Alarm &amp; Datalog Suppression</b>	If any of the relays or digital inputs are selected, any alarms related to this input will be suppressed if the selected relay or digital input is active. At the same time, all datalogs and graphs containing the input will show no data for the duration of the activation.
<b>Input</b>	Select the physical input whose raw value will be used as this virtual input.
<b>Smoothing Factor</b>	Increase the smoothing factor percentage to dampen the response to changes. For example, with a 10% smoothing factor, the next reading shown will consist of an average of 10% of the previous value and 90% of the current value.
<b>Name</b>	The name used to identify the input may be changed.
<b>Type</b>	Select the type of input; either Calculation, Redundant, Raw Value, Disturbance, or Not Used.

### 5.2.23 Virtual Input - Disturbance

A Disturbance type Virtual Input is not a physical input. The value of the virtual input is calculated from a real sensor input plus an equation that defines the real sensor's impact on a control output that is using a different real sensor. A common example is controlling pH based upon a pH input signal, but modifying control based upon the

flow rate, with a Disturbance Type Virtual Input defining the impact of the flow rate on the control output. Based on the disturbance input channel selection, minimum and maximum disturbance input readings, and defined multiplier values at the min and max disturbance readings, this Virtual Input generates a value that is used to multiply to a primary control value. Disturbance input channel values that result in a multiplier output of 1.0 have no impact on the final control output. The output value is restricted between low and high limits to allow more complete control over the impact of disturbance inputs. The value of the multiplier at min disturbance can be either higher or lower than its value at max disturbance, depending upon what effect is desired on the control setpoint.



### Virtual Input Details

The details for a virtual input include the current multiplier value calculated, the current values of the inputs used in the calculation, alarms, the status, and the input type.

### Settings

Touch the Settings icon to view or change the settings related to the virtual input.

<b>Min Disturbance</b>	Enter the value of the disturbance input where the value of the calculated multiplier will be the Value at Min Disturbance value (set below).
<b>Max Disturbance</b>	Enter the value of the disturbance input where the value of the calculated multiplier will be the Value at Max Disturbance (set below).
<b>Value at Min Disturbance</b>	Enter the value of the multiplier that will occur when the disturbance input is at the Min Disturbance value.
<b>Value at Max Disturbance</b>	Enter the value of the multiplier that will occur when the disturbance input is at the Max Disturbance value.
<b>Smoothing Factor</b>	Increase the smoothing factor percentage to dampen the response to changes. For example, with a 10% smoothing factor, the next reading shown will consist of an average of 10% of the previous value and 90% of the current value.
<b>Disable Disturbance Channels</b>	If any of the relays or digital inputs are selected, the multiplier value of the disturbance input is set to 1.0. if the selected relay or digital input is active. Typically this is used to stop using the disturbance function in case of an upset condition.
<b>Disturbance Input</b>	Select the real sensor input that will be used to modify the control output.
<b>Name</b>	The name used to identify the input may be changed.
<b>Type</b>	Select the type of input; either Calculation, Redundant, Raw Value, Disturbance, or Not Used.

## 5.2.24 Remote Modbus Sensor Virtual Input

ONLY AVAILABLE IF A MODBUS KEY FILE HAS BEEN IMPORTED AND THE COMM STATUS IN THE REMOTE COMMUNICATIONS MENU HAS BEEN SET TO MODBUS

The Remote Modbus sensor virtual input is used to simulate a sensor by obtaining the sensor value from a Modbus application via Modbus TCP. This information can be used to activate a control output, be logged or graphed in exactly the same way as a physical sensor.

### Input Details

The details for this type of input include the current value, alarms, the minimum, maximum and average values over the past 24 hours, the status of the input, date/time of the last update, cycle time, 24-hour time, total time, date/time of last total time reset and the current type of input setting.

### Settings

<b>Alarms</b>	Low-Low, Low, High and High-High Alarms limits may be set.
<b>Deadband</b>	This is the Alarm Deadband. For example, if the High Alarm is 7.00, and the deadband is 0.1, the alarm will activate at 7.01 and deactivate at 6.90.
<b>Alarm &amp; Datalog Suppression</b>	If any of the relays or digital inputs are selected, any alarms related to this input will be suppressed if the selected relay or digital input is active. At the same time, all datalogs and graphs containing the input will show no data for the duration of the activation.
<b>Low Range</b>	Enter the low end of the range of the sensor.
<b>High Range</b>	Enter the high end of the range of the sensor.
<b>Modbus Mode</b>	Select Server Mode is the Modbus application will write the value to the input on its own schedule. Select Client if the controller will ask the Modbus application for the latest value.
<b>Remote Device IP</b>	Client mode only. Enter the IP address of the de-vice that will provide the Modbus data.
<b>Data Port</b>	Client mode only. Enter the data port to be used by the Modbus TCP connection.
<b>Reply Timeout</b>	Client mode only. Enter the number of seconds to wait before retrying if no data is received.
<b>Function</b>	Client mode only. Select the Modbus function that the controller will use to read data.
Remote Register	Client mode only. Enter the register that contains the desired data.
Update Period	Client mode only. Enter the frequency that the con-troller will request new data.
Timeout Alarm Delay	Enter the time that will trigger an Update Timeout alarm if no new data has been received from the Modbus application.
Name	The name used to identify the virtual switch may be changed.
Units	Type in the units of measure for the input.
Type	Select the type of sensor to be connected to the digital input channel.

## 5.3 Outputs Menu



Touch the Outputs icon from the Main Menu to view a list of all relay and analog outputs. The Page Down icon pages down the list of outputs, the Page Up icon pages up the list of outputs, the Main Menu icon brings back the previous screen.

Touch an output to access that output's details and settings.

NOTE: When the output control mode or the input assigned to that output is changed, the output reverts to OFF mode. Once you have changed all settings to match the new mode or sensor, you must put the output into AUTO mode to start control.

### 5.3.1 Relay, Any Control Mode

#### Settings

Touch the Settings icon to view or change the settings related to the relay. Settings that are available for any control mode include:

<b>HOA Setting</b>	Select Hand, Off or Auto mode by touching the desired mode.
<b>Output Time Limit</b>	Enter the maximum amount of time that the relay can be continuously activated. Once the time limit is reached, the relay will deactivate until the Reset Output Timeout menu is entered.
<b>Reset Output Timeout</b>	Enter this menu to clear an Output Timeout alarm and allow the relay to control the process again.
<b>Interlock Channels</b>	Select the relays and digital inputs that will interlock this relay, when those other relays are activated in Auto mode. Using Hand or Off to activate relays bypasses the Interlock logic.
<b>Activate With Channels</b>	Select the relays and digital inputs that will activate this relay, when those other relays are activated in Auto mode. Using Hand or Off to activate relays bypasses the Activate With logic.
<b>Minimum Relay Cycle</b>	Enter the number of seconds that will be minimum amount of time that the relay will be in the active or inactive state. Normally this will be set to 0, but if using a motorized ball valve that takes time to open and close, set this high enough that the valve has time to complete its movement.
<b>Hand Time Limit</b>	Enter the amount of time that the relay will activate for when it is in Hand mode.
<b>Reset Time Total</b>	Press the Confirm icon to reset the total accumulated on-time stored for the output back to 0.
<b>Name</b>	The name used to identify the relay may be changed.
<b>Mode</b>	Select the desired control mode for the output.

### 5.3.2 Relay, On/Off Control Mode

#### Output Details

The details for this type of output include the relay on/off state, HOA mode or Interlock status, accumulated on-time, alarms related to this output, current cycle on time, relay type and the current control mode setting.

#### Settings

Touch the Settings icon to view or change the settings related to the relay.

<b>Set point</b>	Enter the sensor process value at which the relay will activate.
<b>Deadband</b>	Enter the sensor process value away from the set point at which the relay will deactivate.
<b>Duty Cycle Period</b>	Using a duty cycle helps to prevent overshooting the set point in applications where the response of the sensor to chemical additions is slow. Specify the amount of time for the cycle, and the percentage of that cycle time that the relay will be active. The relay will be off for the rest of the cycle, even if the set point has not been satisfied. Enter the length of the duty cycle in minutes:seconds in this menu. Set the time to 00:00 if use of a duty cycle is not required.
<b>Duty Cycle</b>	Enter the percentage of the cycle period that the relay will be active. Set the percentage to 100 if use of a duty cycle is not required.
<b>On Delay Time</b>	Enter the delay time for relay activation in hours:minutes:seconds. Set the time to 00:00:00 to immediately activate the relay.
<b>Off Delay Time</b>	Enter the delay time for relay deactivation in hours:minutes:seconds. Set the time to 00:00:00 to immediately deactivate the relay.

<b>Input</b>	Select the sensor to be used by this relay.
<b>Direction</b>	Select the control direction.
<b>Daily Max Time</b>	<p>Enter the maximum amount of accumulated on-time, in Hand or Auto modes, that the relay can have between midnight and midnight the next day. If the time is exceeded, the relay will deactivate, and a Daily Max Timeout alarm will be triggered. The alarm will clear, and relay allowed to reactivate at midnight the next day.</p> <p>If the relay was in Hand mode when the alarm was triggered, it will revert to whichever HOA state it was in prior to being set to Hand.</p> <p>To override the Daily Max Limit for the rest of the day, press Reset Output Timeout.</p>

### 5.3.3 Relay, Flow Timer Control Mode

#### Output Details

The details for this type of output include the relay on/off state, HOA mode or Interlock status, accumulated on-time, remaining feed time, accumulated flow total, alarms related to this output, current cycle on time, relay type and the current control mode setting.

#### Settings

Touch the Settings icon to view or change the settings related to the relay.

<b>Feed Duration</b>	Enter the amount of time for the relay to activate for once the accumulated volume through the water meter has been reached.
<b>Accumulated Volume</b>	Enter the volume of water to pass through the water meter required to trigger the chemical feed.
<b>Flow Input</b>	Select the input to be used to control this output.
<b>Flow Input #2</b>	Select the second flowmeter input to be used to control this output if applicable. The sum of the two flow total volumes will be used to trigger the chemical feed.
<b>Daily Max Time</b>	<p>Enter the maximum amount of accumulated on-time, in Hand or Auto modes, that the relay can have between midnight and midnight the next day. If the time is exceeded, the relay will deactivate, and a Daily Max Timeout alarm will be triggered. The alarm will clear, and relay allowed to reactivate at midnight the next day.</p> <p>If the relay was in Hand mode when the alarm was triggered, it will revert to whichever HOA state it was in prior to being set to Hand.</p> <p>To override the Daily Max Limit for the rest of the day, press Reset Output Timeout.</p>

### 5.3.4 Relay, Bleed and Feed Control Mode

ONLY AVAILABLE IF HVAC MODES ARE ENABLED IN CONFIG MENU – GLOBAL SETTINGS

#### Output Details

The details for this type of output include the relay on/off state, HOA mode or Interlock status, accumulated on-time, alarms related to this output, current cycle on time, relay type and the current control mode setting.

#### Settings

Touch the Settings icon to view or change the settings related to the relay.

<b>Feed Time Limit</b>	Enter the maximum amount of feed time per bleed event
<b>Bleed</b>	Select the relay to be used for Bleed/Blowdown



<b>Daily Max Time</b>	<p>Enter the maximum amount of accumulated on-time, in Hand or Auto modes, that the relay can have between midnight and midnight the next day. If the time is exceeded, the relay will deactivate, and a Daily Max Timeout alarm will be triggered. The alarm will clear, and relay allowed to reactivate at midnight the next day.</p> <p>If the relay was in Hand mode when the alarm was triggered, it will revert to whichever HOA state it was in prior to being set to Hand.</p> <p>To override the Daily Max Limit for the rest of the day, press Reset Output Timeout.</p>
-----------------------	--

### 5.3.5 Relay, Bleed then Feed Control Mode

ONLY AVAILABLE IF HVAC MODES ARE ENABLED IN CONFIG MENU – GLOBAL SETTINGS

#### Output Details

The details for this type of output include the relay on/off state, HOA mode or Interlock status, accumulated on-time, remaining feed time, the accumulated bleed time, alarms related to this output, current cycle on time, relay type and the current control mode setting.

#### Settings

Touch the Settings icon to view or change the settings related to the relay.

<b>Feed Percentage</b>	Enter the % of bleed relay activation time to use for the feed relay activation time
<b>Feed Time Limit</b>	Enter the maximum amount of feed time per bleed event
<b>Reset Timer</b>	Use this menu to cancel the current feed cycle
<b>Bleed</b>	Select the relay to be used for Bleed/Blowdown
<b>Daily Max Time</b>	<p>Enter the maximum amount of accumulated on-time, in Hand or Auto modes, that the relay can have between midnight and midnight the next day. If the time is exceeded, the relay will deactivate, and a Daily Max Timeout alarm will be triggered. The alarm will clear, and relay allowed to reactivate at midnight the next day.</p> <p>If the relay was in Hand mode when the alarm was triggered, it will revert to whichever HOA state it was in prior to being set to Hand.</p> <p>To override the Daily Max Limit for the rest of the day, press Reset Output Timeout.</p>

### 5.3.6 Relay, Percent Timer Control Mode

#### Output Details

The details for this type of output include the relay on/off state, HOA mode or Interlock status, cycle time, accumulated on-time, alarms related to this output, current cycle on time, relay type and the current control mode setting.

#### Settings

Touch the Settings icon to view or change the settings related to the relay.

<b>Sample Period</b>	Enter the duration of the sample period.
<b>Feed Percentage</b>	Enter the % of the sample period time to use for the feed relay activation time

### 5.3.7 Relay, Biocide Timer Control Mode

ONLY AVAILABLE IF HVAC MODES ARE ENABLED IN CONFIG MENU – GLOBAL SETTINGS

#### Basic Timer Operation

This algorithm is typically used to provide a baseline amount of chlorine for disinfection, and periodically shocking the system with a larger dose. During normal operation, the relay will be reacting to the sensor to maintain a set point within a programmable Deadband, as described in On/Off Control Mode above. When a Spike event triggers, the algorithm will change from the normal set point to the Spike Set Point, for the programmed time. Once the time expires, control to the normal set point resumes.

### Basic Biocide Operation

When a biocide event triggers, the algorithm will first prebleed (if a prebleed is programmed) for the set amount of prebleed time or down to the set prebleed conductivity. Then the biocide relay is turned on for the set duration. This is followed by a post-bio add lockout that blocks the bleed relay from turning on for a set amount of bleed lockout time.

### Special Condition Handling

#### Prebleed

If both a time limit and a conductivity limit are set, the time limit takes precedence. The bleed relay will turn off once the time limit is reached or when the prebleed conductivity limit is reached (whichever occurs first). If the prebleed has a conductivity limit set, then the time limit can't be set to zero, as this would allow the prebleed to last forever if the conductivity limit is never reached.

#### Overlapping biocide events

If a second biocide event occurs while the first one is still active (in prebleed, biocide add or lockout), the second event will be ignored. An Event Skipped alarm will be set.

#### Interlock Conditions

Interlocks override the relay control, but do not change the operation of the timers or related bleed control.

A no-flow (or other interlock) condition does not delay a biocide add. The biocide add duration timer will continue even if the relay is locked out due to a no-flow or other interlock condition. This will prevent delayed biocide adds which can potentially cause higher than expected biocide concentrations in the system when two biocides adds occur close to the same time. Not allowing delayed biocide adds will also prevent incompatible biocides getting added at close to the same time.

#### “Activate With” Conditions

“Activate with channels” settings override the relay control, but do not change the operation of the timers or related bleed control. The biocide timer continues counting biocide add time when the biocide relay is forced on, and ends at the expected time (biocide event start time plus duration). If the “activate with” condition continues after the end of the biocide feed time, the relay remains activated.

#### Alarms

An Event Skipped alarm is set when a second biocide event occurs while one event is still running (either in prebleed, biocide add or post-biocide add lockout).

An Event Skipped alarm is also set when the biocide add relay never turns on during a biocide add because of an interlock condition.

The alarm is cleared when the relay is next activated for any reason (the next timer event or HAND mode or “activate with” force on condition).

### Output Details

The details for this type of output include the relay on/off state, HOA mode or Interlock status, accumulated on-time, alarms related to this output, current cycle on time, relay type and the current control mode setting. The current week number and day of the week is displayed (even if there is no multi-week repetition event programmed). Cycle Time shows the time counting down of the currently active part of the biocide cycle (pre-bleed, biocide feed, or post biocide feed lockout of the bleed).

## Settings

Touch the Settings icon to view or change the settings related to the relay.

<b>Event 1 (through 10)</b>	Enter these menus to program timer events via the menus below:
<b>Repetition</b>	Select the time cycle to repeat the event: Daily, 1 Week, 2 Week, 4 Week, or None. An event means that the output is turned on at the same time of day, for the same amount of time, and except for the Daily cycle, on the same day of the week.

<b>Week</b>	Only appears if Repetition is longer than 1 Week. Select the week during which the event will occur.
<b>Day</b>	Only appears if Repetition is longer than Daily. Select the day of the week during which the event will occur.
<b>Start Time</b>	Enter the time of day to start the event.
<b>Duration</b>	Enter the amount of time that the relay will be on.
<b>Bleed</b>	Select the relay to be used for Bleed/Blowdown
<b>Prebleed Time</b>	If lowering the conductivity prior to feeding biocide is desired using a fixed time instead of a specific conductivity setting, enter the amount of time for the prebleed. Also may be used to apply a time limit on a conductivity based prebleed.
<b>Prebleed To</b>	If lowering the conductivity prior to feeding biocide is desired, enter the conductivity value. If no prebleed is required, or if a time-based prebleed is preferred, set the conductivity value to 0.
<b>Cond Input</b>	Select the sensor to be used to control the prebleed relay selected above.
<b>Bleed Lockout</b>	Enter the amount of time to lockout bleed after the biocide feed is complete.
<b>Add Last Missed</b>	Select Enabled if the controller should delay start the most recent Biocide cycle until immediately after an Interlock clears, or Disabled if all Biocide feed should be skipped if there is an Interlock condition at the time the add was due to start.

### 5.3.8 Relay, Alarm Output Mode

#### Output Details

The details for this type of output include the relay on/off state, HOA mode or Interlock status, accumulated on-time, alarms related to this output, current cycle on time, relay type and the current control mode setting.

#### Settings

Touch the Settings icon to view or change the settings related to the relay.

<b>Alarm Mode</b>	Select the alarm conditions that will put the relay into the alarm state: All Alarms Selected Alarms
<b>On Delay Time</b>	Enter the delay time for relay activation in hours:minutes:seconds. Set the time to 00:00:00 to immediately activate the relay.
<b>Off Delay Time</b>	Enter the delay time for relay deactivation in hours:minutes:seconds. Set the time to 00:00:00 to immediately deactivate the relay.
<b>Select Alarms</b>	Scroll through the list of all inputs and outputs, as well as System Alarms and Network (Ethernet) alarms. Touch the parameter to select alarms related to that parameter, then scroll through the list of alarms. Touch each alarm to check the box indicating the alarm is selected. Touch the Confirm icon when finished with that parameter to save the changes. Repeat for each input and output.
<b>Output</b>	Select if the relay will be active when in the alarm state (Normally Open) or if the relay will be active when not in the alarm state (Normally Closed).

### 5.3.9 Relay, Time Proportional Control Mode

#### Output Details

The details for this type of output include the relay on/off state, HOA mode or Interlock status, the current % on time calculated for the cycle, the current point in the cycle time, accumulated on-time, alarms related to this output, current cycle on time, relay type and the current control mode setting.

## Settings

Touch the Settings icon to view or change the settings related to the relay.

<b>Set point</b>	Enter the sensor process value at which the relay will be off for the entire Sample Period.
<b>Proportional Band</b>	Enter the distance that the sensor process value is away from the set point at which the relay will be on for the entire Sample Period.
<b>Sample Period</b>	Enter the duration of the sample period.
<b>Input</b>	Select the sensor to be used by this relay.
<b>Direction</b>	Select the control direction.
<b>Daily Max Time</b>	<p>Enter the maximum amount of accumulated on-time, in Hand or Auto modes, that the relay can have between midnight and midnight the next day. If the time is exceeded, the relay will deactivate, and a Daily Max Timeout alarm will be triggered. The alarm will clear, and relay allowed to reactivate at midnight the next day.</p> <p>If the relay was in Hand mode when the alarm was triggered, it will revert to whichever HOA state it was in prior to being set to Hand.</p> <p>To override the Daily Max Limit for the rest of the day, press Reset Output Timeout.</p>

### 5.3.10 Relay, Intermittent Sampling Control Mode

ONLY AVAILABLE IF HVAC MODES ARE ENABLED IN CONFIG MENU – GLOBAL SETTINGS

In an Intermittent Sampling with Proportional Blowdown control mode, the controller reads an analog input on a timed schedule, and the relay responds to maintain the conductivity value at the set point by activating for a programmable amount of time that varies with the deviation from the set point.

The relay goes through a sequence of activation/deactivation as described below. The intended purpose of this algorithm is boiler blowdown. A sample cannot be supplied to the sensor continuously in many boilers because a recirculating loop is not possible, and it would be a waste of hot water to constantly run a sample to a drain. A valve is opened intermittently to supply a sample to the sensor.

Where a non-ideal installation of the sensor can cause the sample to flash to steam, and give a false low reading, this can be corrected by taking the reading with the sample held in the pipe with the sampling valve closed, so the sample is at boiler pressure and therefore back in the liquid state. Enable Trap Sample if this is the case. Because the conductivity reading cannot be trusted while the valve is open, the blowdown is timed rather than in direct response to a sensor reading. Rather than relying upon a fixed time, where the blowdown could be much longer than necessary if the reading is just barely off the set point value, proportional blowdown adjusts the time appropriately.

If Trap Sample is Disabled, then the blowdown is not timed, and the Hold Time and Maximum Blowdown time are not used. The blowdown valve will stay open until the conductivity is below set point. In this case the Output Time Limit menu is available to stop the blowdown if the sensor is unresponsive.

Note that the software will not allow two relays using Intermittent Sampling to be assigned to the same sensor input; the previous relay set up will change to Off mode.

#### Output Details

The details for this type of output include the relay on/off state, relay status (HOA mode, Interlock status, Intermittent Sampling cycle step, etc.), time remaining for the active Intermittent Sampling cycle step, alarms related to this output, current cycle on time, relay type, the live reading of the conductivity, and the current control mode setting.

## Settings

Touch the Settings icon to view or change the settings related to the relay.

<b>Set point</b>	Enter the conductivity value below which the controller will not start a blowdown cycle.
------------------	--

<b>Proportional Band</b>	(only shown if trap sample is enabled) Enter the conductivity value above the set point at which the maximum blowdown time will occur. For example, if the Set point is 2000 uS/cm, and the Proportional Band is 200 uS/cm, then if the conductivity is above 2200 uS/cm the blowdown valve will open for the Maximum Blowdown time described below. If the conductivity of the trapped sample is 2100 uS/cm, the blowdown valve will open for half the Maximum Blowdown time.
<b>Deadband</b>	(only shown if trap sample is disabled) Enter the sensor process value away from the set point at which the relay will deactivate.
<b>Sample Time</b>	Enter the length of time the blowdown valve will be open in order to capture a fresh sample of boiler water.
<b>Hold Time</b>	(only shown if trap sample is enabled) Enter the length of time the blowdown valve will be closed in order to ensure that the captured sample is at boiler pressure.
<b>Maximum Blowdown</b>	(only shown if trap sample is enabled) Enter the maximum length of time that the blowdown valve will be open, when the conductivity of the captured sample is above the set point plus the proportional band.
<b>Wait Time</b>	Enter the time to wait to sample the water again once the captured sample is below set point.
<b>Trap Sample</b>	Enable or disable trapping of the sample.
<b>Cond Input</b>	Select the sensor to be used by this relay.

### 5.3.11 Relay, Manual Mode

#### Output Details

The details for this type of output include the relay on/off state, HOA mode or Interlock status, accumulated on-time, alarms related to this output, current cycle on time, relay type and the current control mode setting.

#### Settings

A Manual relay will activate if the HOA mode is Hand, or if it is Activated With another channel.

<b>On Delay Time</b>	Enter the delay time for relay activation in hours:minutes:seconds. Set the time to 00:00:00 to immediately activate the relay.
<b>Off Delay Time</b>	Enter the delay time for relay deactivation in hours:minutes:seconds. Set the time to 00:00:00 to immediately deactivate the relay.

### 5.3.12 Relay, Pulse Proportional Control Mode

ONLY AVAILABLE IF CONTROLLER INCLUDES PULSE OUTPUT HARDWARE

#### Output Details

The details for this type of output include the relay pulse rate, HOA mode or Interlock status, accumulated on-time, alarms related to this output, current cycle on time, relay type and the current control mode setting.

#### Settings

Touch the Settings icon to view or change the settings related to the relay.

<b>Set point</b>	Enter the sensor process value at which the output will pulse at the Minimum Output % set below.
<b>Proportional Band</b>	Enter the distance that the sensor process value is away from the set point beyond which the output will be pulsing at the Maximum Output % set below.
<b>Minimum Output</b>	Enter the lowest possible pulse rate as a percentage of the Maximum Stroke Rate set below (normally 0%).
<b>Maximum Output</b>	Enter the highest possible pulse rate as a percentage of the Maximum Stroke Rate set below.
<b>Maximum Rate</b>	Enter the maximum pulse rate that the metering pump is designed to accept (10 - 2400 pulse/minute range).
<b>Input</b>	Select the sensor to be used by this relay.

<b>Direction</b>	Set the control direction.
------------------	----------------------------

### 5.3.13 Relay, PID Control Mode

ONLY AVAILABLE IF CONTROLLER INCLUDES PULSE OUTPUT HARDWARE & HVAC MODE IS DISABLED  
 The PID algorithm controls a solid state relay using standard Proportional-Integral-Derivative control logic. The algorithm provides feedback control based on an error value continuously calculated as the difference between a measured process variable and a desired set point. Tuning settings specify the response for proportional (the size of the error), integral (the time that the error has been present), and derivative (the rate of change for the error) parameters. With proper tuning, the PID control algorithm can hold the process value close the set point while minimizing overshoot and undershoot.

#### Normalized Error

The error value versus set point that is calculated by the controller is normalized and represented as percent of full scale. As a result, tuning parameters entered by the user are not dependent upon the scale of the process variable and the PID response with similar settings will be more consistent even when using different types of sensor inputs.

The scale used to normalize the error is dependent upon the type of sensor selected. By default, the full nominal range of the sensor is used. This range is editable by the user if tighter control is desired.

#### PID Equation Formats

The controller supports two different forms of the PID equation as specified by the Gain Form setting. The two forms require different units for entry of the PID tuning parameters.

##### Standard

The standard form is more commonly used in industry because its time-based settings for the integral and derivative coefficients are more meaningful. This form is selected by default.

Parameter	Description	Units
$K_p$	Gain	unitless
$T_i$	Integral Time	seconds or seconds/repeat
$T_d$	Derivative Time	seconds

$$Output (\%) = K_p \left[ e(t) + \frac{1}{T_i} \int e(t) dt + T_d \frac{de(t)}{dt} \right]$$

Parameter	Description	Units
$e(t)$	Current Error	% of full scale
$dt$	Delta Time Between Readings	seconds
$de(t)$	Difference Between Current Error & Previous Error	% of full scale

##### Parallel

The parallel form allows the user to enter all parameters as Gains. In all cases, larger gain values result in faster output response.

Parameter	Description	Units
$K_p$	Proportional Gain	unitless
$K_i$	Integral Gain	1/seconds
$K_d$	Derivative Gain	seconds

$$\text{Output (\%)} = K_p e(t) + K_i \int e(t)dt + K_d \frac{de(t)}{dt}$$

### Integral Value Management

To determine the integral component of the PID calculation, the controller software must maintain a running total of the accumulated area under the error curve (Current Integral). The sign of the value added to the accumulated Current Integral during each cycle may be positive or negative based on the current Direction setting as well as the relative values of the current process reading and the set point.

### Override Control

The Current Integral accumulates when the output is set to Auto mode. If the controller is switched to Off mode, the value no longer accumulates, but it is not cleared. Therefore, PID control will resume where it left off if the controller is switched from Off back to Auto. Similarly, accumulation of the Control Integral will be suspended if the output is interlocked and resume after the lock-out is removed.

### Bumpless Transfer

When the output is switched from Hand to Auto mode, the controller calculates a value for the Current Integral using the current error to generate the same output percent as the Hand Output setting. This calculation does not use the Derivative tuning setting to minimize errors from momentary fluctuations in the input signal. This feature ensures a smooth transition from manual to automatic control with minimal overshoot or undershoot as long as the user sets the Hand Output percentage close to the value that the process is expected to require for optimal control in Auto mode.

### Wind-up Suppression

The Current Integral value that is accumulating while the output is set to Auto can become very large or very small if the process value remains on the same side of the set point for a prolonged period of time. However, the controller may not be able to continue to respond if its output is already set to the minimum or maximum limits (0-100% by default). This condition is referred to as Control Wind-Up and can result severe overshoot or undershoot after a prolonged upset has ended.

For example, if the process value remains far below the set point despite a control output being pinned at 100%, the Current Integral will continue to accumulate errors (wind-up). When the process value finally rises to above the set point, negative errors will begin to decrease the Current Integral value. However, the value may remain large enough to keep the output at 100% long after the set point is satisfied. The controller will overshoot the set point and the process value will continue to rise.

To optimize system recovery after wind-up situations, the controller suppresses updates to the Current Integral that would drive the output beyond its minimum or maximum limit. Ideally, the PID parameters will be tuned and the control elements (pump, valves, etc.) will be sized properly so that the output never reaches its minimum or maximum limit during normal control operations. But with this wind-up suppression feature, overshoot will be minimized should that situation occur.

### Output Details

The details for this type of output include the pulse rate in %, HOA mode or Interlock status, input value, current integral, current and accumulated on-times, alarms related to this output, relay type, and the current control mode setting.

<b>Set Point</b>	Numeric entry of a process value used as a target for PID control. The default value, units and display format (number of decimal places) used during data entry are defined based on the Input channel setting selected.
<b>Gain</b>	When the Gain Form setting is Standard, this unitless value is multiplied by the total of the proportional, integral, and derivative terms to determine the calculated output percent.

<b>Proportional Gain</b>	When the Gain Form setting is Parallel, this unitless value is multiplied by the normalized error (current process value versus set point) to determine the proportional component of the calculated output percent.
<b>Integral Time</b>	When the Gain Form setting is Standard, this value is divided into the integral of the normalized error (area under the error curve), then multiplied by the Gain to determine the integral component of the calculated output percent.
<b>Integral Gain</b>	When the Gain Form setting is Parallel, this value is multiplied by the integral of the normalized error (area under the error curve) to determine the integral component of the calculated output percent.
<b>Derivative Time</b>	When the Gain Form setting is Standard, this value is multiplied by the change in error between the current reading and the previous reading, then multiplied by the Gain to determine the derivative component of the calculated output percent.
<b>Derivative Gain</b>	When the Gain Form setting is Parallel, this value is multiplied by the change in error between the current reading and the previous reading to determine the derivative component of the calculated output percent.
<b>Reset PID Integral</b>	The PID Integral Value is a running total of the accumulated area under the error curve (Current Integral). When this menu option is selected, this total is set to zero and the PID algorithm is reset to its initial state.
<b>Minimum Output</b>	Enter the lowest possible pulse rate as a percentage of the Maximum Stroke Rate set below (normally 0%).
<b>Maximum Output</b>	Enter the highest possible pulse rate as a percentage of the Maximum Stroke Rate set below.
<b>Maximum Rate</b>	Enter the maximum pulse rate that the metering pump is designed to accept (10 – 2400 pulse/minute range).
<b>Input</b>	Select the sensor to be used by this relay
<b>Direction</b>	Set the control direction. This setting is used to determine the sign of the calculated error (current process value versus set point) and allows flexible control with only positive values for all PID tuning parameters.
<b>Input Minimum</b>	The low end of the sensor input range, used to normalize errors into percent of full scale units. These values are set to the nominal range of the selected input sensor by default.
<b>Input Maximum</b>	The high end of the sensor input range, used to normalize errors into percent of full scale units. These values are set to the nominal range of the selected input sensor by default.
<b>Gain Form</b>	Select the PID Equation Format used to enter tuning parameters.

### 5.3.14 Relay, Dual Set Point Mode

#### Output Details

The details for this type of output include the relay on/off state, HOA mode or Interlock status, accumulated on-time, alarms related to this output, current cycle on time, relay type and the current control mode setting.

#### Settings

Touch the Settings icon to view or change the settings related to the relay.

<b>Set point</b>	Enter the first sensor process value at which the relay will activate.
<b>Set point 2</b>	Enter the second sensor process value at which the relay will activate.
<b>Deadband</b>	Enter the sensor process value away from the set point at which the relay will deactivate.
<b>Duty Cycle Period</b>	Using a duty cycle helps to prevent overshooting the set point in applications where the response of the sensor to chemical additions is slow. Specify the amount of time for the cycle, and the percentage of that cycle time that the relay will be active. The relay will be off for the rest of the cycle, even if the set point has not been satisfied. Enter the length of the duty cycle in minutes:seconds in this menu. Set the time to 00:00 if use of a duty cycle is not required.



<b>Duty Cycle</b>	Enter the percentage of the cycle period that the relay will be active. Set the percentage to 100 if use of a duty cycle is not required.
<b>On Delay Time</b>	Enter the delay time for relay activation in hours:minutes:seconds. Set the time to 00:00:00 to immediately activate the relay.
<b>Off Delay Time</b>	Enter the delay time for relay deactivation in hours:minutes:seconds. Set the time to 00:00:00 to immediately deactivate the relay.
<b>Input</b>	Select the sensor to be used by this relay.
<b>Direction</b>	Select the control direction. In Range will activate the relay when the input reading is between the two set points. Out of Range will activate the relay when the input reading is outside the two set points.
<b>Daily Max Time</b>	<p>Enter the maximum amount of accumulated on-time, in Hand or Auto modes, that the relay can have between midnight and midnight the next day. If the time is exceeded, the relay will deactivate, and a Daily Max Timeout alarm will be triggered. The alarm will clear, and relay allowed to reactivate at midnight the next day.</p> <p>If the relay was in Hand mode when the alarm was triggered, it will revert to whichever HOA state it was in prior to being set to Hand.</p> <p>To override the Daily Max Limit for the rest of the day, press Reset Output Timeout.</p>

### 5.3.15 Relay, Timer Control Mode

ONLY AVAILABLE IF HVAC MODES ARE DISABLED IN CONFIG MENU – GLOBAL SETTINGS

#### Basic Timer Operation

When a timer event triggers the algorithm will activate the relay for the programmed time.

#### Special Condition Handling

##### Overlapping timer events

If a second timer event occurs while the first one is still active, the second event will be ignored. An Event Skipped alarm will be set.

##### Interlock Conditions

Interlocks override the relay control, but do not change the operation of the timer control.

A digital input or output interlock condition does not delay the relay activation. The relay activation duration timer will continue even if the relay is deactivated due to an interlock condition. This will prevent delayed events which can potentially cause problems in they do not occur at the correct time.

##### “Activate With” Conditions

“Activate with channels” settings override the relay control, but do not change the operation of the timer control. The relay activation duration timer continues counting when the timer relay is forced on, and ends at the expected time (event start time plus duration). If the “activate with” condition continues after the end of the event time, the relay remains activated.

##### Alarms

An Event Skipped alarm is set when a second timer event occurs while one event is still running.

An Event Skipped alarm is also set when the timer relay never turns on during an event because of an interlock condition.

The alarm is cleared when the relay is next activated for any reason (the next timer event or HAND mode or “activate with” force on condition).

#### Output Details

The details for this type of output include the relay on/off state, HOA mode or Interlock status, accumulated on-time, alarms related to this output, current cycle on time, relay type and the current control mode setting. The current week number and day of the week is displayed (even if there is no multi-week repetition event programmed). Cycle Time shows the time counting down of the currently active part of the timer cycle.

Settings 

Touch the Settings icon to view or change the settings related to the relay.

<b>Event 1 (through 10)</b>	Enter these menus to program timer events via the menus below:
<b>Repetition</b>	Select the time cycle to repeat the event: Hourly, Daily, 1 Week, 2 Week, 4 Week, or None. An event means that the output is turned on at the same time of day, for the same amount of time, and except for the Daily cycle, on the same day of the week.
<b>Week</b>	Only appears if Repetition is longer than 1 Week. Select the week during which the event will occur.
<b>Day</b>	Only appears if Repetition is longer than Daily. Select the day of the week during which the event will occur.
<b>Events Per Day</b>	Only appears if Repetition is Hourly. Select the number of events per day. The events occur on the Start Time and then evenly spaced throughout the day.
<b>Start Time</b>	Enter the time of day to start the event.
<b>Duration</b>	Enter the amount of time that the relay will be on.
<b>Add Last Missed</b>	Select Enabled if the controller should delay start the most recent Biocide cycle until immediately after an Interlock clears, or Disabled if all Biocide feed should be skipped if there is an Interlock condition at the time the add was due to start.

### 5.3.16 Relay, Probe Wash Control Mode

#### Basic Timer Operation

When a Probe Wash event triggers, the algorithm will activate the relay for the programmed time. The relay will activate a pump or valve to supply a cleaning solution to the sensor or sensors. The output of the selected sensors will either be held or disabled during the cleaning cycle, and for a programmable hold time after the cleaning cycle.

#### Special Condition Handling

##### Overlapping timer events

If a second timer event occurs while the first one is still active, the second event will be ignored. An Event Skipped alarm will be set.

##### Interlock Conditions

Interlocks override the relay control, but do not change the operation of the timer control.

A digital input or output interlock condition does not delay the relay activation. The relay activation duration timer will continue even if the relay is deactivated due to an interlock condition. This will prevent delayed events which can potentially cause problems in they do not occur at the correct time.

##### “Activate With” Conditions

“Activate with channels” settings override the relay control, but do not change the operation of the timer control. The relay activation duration timer continues counting when the timer relay is forced on, and ends at the expected time (event start time plus duration). If the “activate with” condition continues after the end of the event time, the relay remains activated.

##### Alarms

An Event Skipped alarm is set when a second timer event occurs while one event is still running.

An Event Skipped alarm is also set when the timer relay never turns on during an event because of an interlock condition.

The alarm is cleared when the relay is next activated for any reason (the next timer event or HAND mode or “activate with” force on condition).

#### Output Details

The details for this type of output include the relay on/off state, HOA mode or Interlock status, accumulated on-time, alarms related to this output, current cycle on time, relay type and the current control mode setting. The current week number and day of the week is displayed (even if there is no multi-week repetition event programmed). Cycle Time shows the time counting down of the currently active part of the timer cycle.

## Settings

Touch the Settings icon to view or change the settings related to the relay.

<b>Event 1 (through 10)</b>	Enter these menus to program timer events via the menus below:
<b>Repetition</b>	Select the time cycle to repeat the event: Hourly, Daily, 1 Week, 2 Week, 4 Week, or None. An event means that the output is turned on at the same time of day, for the same amount of time, and except for the Daily cycle, on the same day of the week.
<b>Week</b>	Only appears if Repetition is longer than 1 Week. Select the week during which the event will occur.
<b>Day</b>	Only appears if Repetition is longer than Daily. Select the day of the week during which the event will occur.
<b>Events Per Day</b>	Only appears if Repetition is Hourly. Select the number of events per day. The events occur on the Start Time and then evenly spaced throughout the day.
<b>Start Time</b>	Enter the time of day to start the event.
<b>Duration</b>	Enter the amount of time that the relay will be on.
<b>Input</b>	Select the sensor that will be washed.
<b>Input 2</b>	Select the second sensor, if applicable, that will be washed.
<b>Sensor Mode</b>	Select the effect that the probe wash event will have on any control outputs that use the sensor(s) being washed. The options are to either Disable the sensor readings (turn the control output off) or Hold the sensor reading at the last valid sensor reading prior to the start of the probe wash event.
<b>Hold Time</b>	Enter the amount of time needed to hold the sensor reading after the event has finished, in order for the wash solution to be replaced by process solution.

### 5.3.17 Relay, Spike Control Mode

#### Basic Timer Operation

This algorithm is typically used to provide a baseline amount of chlorine for disinfection, and periodically shocking the system with a larger dose. During normal operation, the relay will be reacting to the sensor to maintain a set point within a programmable Deadband, as described in On/Off Control Mode above. When a Spike event triggers, the algorithm will change from the normal set point to the Spike Set Point, for the programmed time. Once the time expires, control to the normal set point resumes. The Onset Time setting allows the user to decide if the programmed spike duration time starts counting down immediately, or if the controller will wait until the higher set point is achieved

(or the onset time expires, whichever comes first) before starting the spike Duration timer.

#### Special Condition Handling

##### Overlapping timer events

If a second timer event occurs while the first one is still active, the second event will be ignored. An Event Skipped alarm will be set.

##### Interlock Conditions

Interlocks override the relay control, but do not change the operation of the timer control.

A digital input or output interlock condition does not delay the relay activation. The relay activation duration timer will continue even if the relay is deactivated due to an interlock condition. This will prevent delayed events which can potentially cause problems in they do not occur at the correct time.

##### “Activate With” Conditions

“Activate with channels” settings override the relay control, but do not change the operation of the timer control.

The relay activation duration timer continues counting when the timer relay is forced on, and ends at the expected time (event start time plus duration). If the “activate with” condition continues after the end of the event time, the relay remains activated.

### Alarms

An Event Skipped alarm is set when a second timer event occurs while one event is still running.

An Event Skipped alarm is also set when the timer relay never turns on during an event because of an interlock condition.

The alarm is cleared when the relay is next activated for any reason (the next timer event or HAND mode or “activate with” force on condition).

### Output Details

The details for this type of output include the relay on/off state, HOA mode or Interlock status, accumulated on-time, current cycle on time, relay type and alarms. The current week number and day of the week is displayed (even if there is no multi-week repetition event programmed). Cycle Time shows the time counting down of the currently active part of the cycle.

### Settings

Press the Settings key view or change the settings related to the relay.

<b>Set point</b>	Enter the sensor process value at which the relay will activate.
<b>Spike Set point</b>	Enter the sensor process value at which the relay will activate during the Spike Event time.
<b>Deadband</b>	Enter the sensor process value away from the set point at which the relay will deactivate. The same Deadband is used for the normal Set Point and the Spike Set Point.
<b>Onset Time</b>	The onset time determines when the duration timer starts. If set to zero, the duration time starts immediately. If set higher than that, the controller will not start the duration timer until the spike set point is achieved, or until the onset time is over, whichever comes first.
<b>Duty Cycle Period</b>	Using a duty cycle helps to prevent overshooting the set point in applications where the response of the sensor to chemical additions is slow. Specify the amount of time for the cycle, and the percentage of that cycle time that the relay will be active. The relay will be off for the rest of the cycle, even if the set point has not been satisfied.  Enter the length of the Duty Cycle Period in minutes:seconds in this menu. Set the time to 00:00 if use of a duty cycle is not required.
<b>Duty Cycle</b>	Enter the percentage of the cycle period that the relay will be active. Set the percentage to 100 if use of a duty cycle is not required.
<b>Event 1 (through 8)</b>	Enter these menus to program spike events via the menus below:
<b>Repetition</b>	Select the time cycle to repeat the event: Daily, 1 Week, 2 Week, 4 Week, or None. An event means that the output is turned on at the same time of day, for the same amount of time, and except for the Daily cycle, on the same day of the week.
<b>Week</b>	Only appears if Repetition is longer than 1 Week. Select the week during which the event will occur.
<b>Day</b>	Only appears if Repetition is longer than Daily. Select the day of the week during which the event will occur.
<b>Start Time</b>	Enter the time of day to start the event.
<b>Duration</b>	Enter the amount of time that the relay will be on.
<b>Input</b>	Select the sensor to be used by this relay.
<b>Direction</b>	Select the control direction.

<b>Daily Max Time</b>	<p>Enter the maximum amount of accumulated on-time, in Hand or Auto modes, that the relay can have between midnight and midnight the next day. If the time is exceeded, the relay will deactivate, and a Daily Max Timeout alarm will be triggered. The alarm will clear, and relay allowed to reactivate at midnight the next day.</p> <p>If the relay was in Hand mode when the alarm was triggered, it will revert to whichever HOA state it was in prior to being set to Hand.</p> <p>To override the Daily Max Limit for the rest of the day, press Reset Output Timeout.</p>
-----------------------	--

### 5.3.18 Relay Output, Pulse Mass Balance Mode

ONLY AVAILABLE IF CONTROLLER INCLUDES PULSE OUTPUT HARDWARE

#### Overview

In Pulse Mass Balance control mode, the controller monitors the rate of flow through an analog or paddlewheel flow meter, and continuously adjusts the proportional band to achieve a target product level. The user enters the target PPM product level and the data necessary to calculate the proportional band (the water flow rate at which the maximum pulse rate will occur) required to maintain the target PPM with that flow rate of water. A performance input may be selected, normally corrosion, to trim the target product level setting based on that input reading.

$$\% \text{ output} = \frac{\text{Target PPM} \times \text{Water Flow Rate (liter/min or gal/min)}}{\text{Cycles} \times \text{Pump Rating (liter or gal/hr)} \times \text{Pump Setting (\%)} \times \text{Specific Gravity} \times 166.67}$$

$$\% \text{ output} = \frac{\text{Target PPM} \times \text{Water Flow Rate (m}^3\text{/min)}}{\text{Cycles} \times \text{Pump Rating (liter/hr)} \times \text{Pump Setting (\%)} \times \text{Specific Gravity} \times 0.16667}$$

#### Control Operation

If the output is continuously on for longer than the Output Time Limit, then output will deactivate.

#### Output Details

The details for this type of output include the output %, HOA mode or Interlock status, alarms related to this output, flow input value, current cycle on time, total accumulated on-time, raw pulse rate output, and the current control mode setting.

#### Settings

Touch the Settings icon to view or change the settings related to the relay.

<b>Target</b>	Appears if no Performance Input has been selected. Enter the desired PPM set point for the product.
<b>Min Product Level</b>	Appears if a Performance Input has been selected. Enter the lowest desired PPM set point for the product.
<b>Max Product Level</b>	Appears if a Performance Input has been selected. Enter the highest desired PPM set point for the product.
<b>Min Trim Input</b>	Appears if a Performance Input has been selected. Enter the value of the trim input that will result in the minimum product level set point being used.

<b>Max Trim Input</b>	Appears if a Performance Input has been selected. Enter the value of the trim input that will result in the maximum product level set point being used.
<b>Pump Rating</b>	Enter the maximum flow rate for the metering pump.
<b>Pump Setting</b>	Enter the stroke length setting for the metering pump, in percent.
<b>Specific Gravity</b>	Enter the specific gravity of the product to be added.
<b>Maximum Rate</b>	Enter the maximum pulse rate that the metering pump is designed to accept (10 – 2400 pulse/minute range).
<b>Flow Input</b>	Select the flow meter to be used as an input for this control relay.
<b>Cycles Input</b>	Select the virtual input that is programmed as a Ratio calculation of the system conductivity/makeup conductivity, or select None.
<b>Low Cycles Limit</b>	Appears if a Cycles Input has been selected. Enter the lower limit for cycles of concentration, if used. The calculated on-time is limited to a maximum value if the cycles of concentration gets too low.
<b>Performance Input</b>	Select the input that will be used to trim the product level set point. A typical application for this is to use a corrosion sensor as the performance input to adjust the PPM setpoint.

### 5.3.19 Relay, Target PPM Control Mode

ONLY AVAILABLE IF HVAC MODE IS ENABLED

#### Overview

In Target PPM control mode, the controller monitors the total volume of flow through up to two analog or digital flow meters, and after a programmable volume has been accumulated, the relay activates for a calculated time to achieve a target PPM level.

The user enters the target PPM, the volume of water to trigger the chemical feed, and the data necessary to calculate the pump on-time required to maintain the target PPM in that volume of water.

$$\text{Pump On-Time (sec.)} = \frac{\text{Accumulator Setpoint (gal or l)} \times \text{Product Level} \times 0.0036}{\text{Cycles} \times \text{Pump Rating (gal or l/hr.)} \times \text{Pump Setting (\%)} \times \text{Specific Gravity (g/cm}^3\text{)}}$$

$$\text{Pump On-Time (sec.)} = \frac{\text{Accumulator Setpoint (m}^3\text{)} \times \text{Product Level} \times 3.6}{\text{Cycles} \times \text{Pump Rating (l/hr)} \times \text{Pump Setting (\%)} \times \text{Specific Gravity (g/cm}^3\text{)}}$$

#### Control Operation

As flow accumulates, the controller updates a field called Accumulator Total. When this value is greater than or equal to the value set for the Accumulator Volume, the relay activates for the calculated number of seconds, and the accumulated total is reduced by the accumulator volume amount.

If the trigger volume is achieved again before the activation time has expired, the newly calculated on-time per unit volume is added to the remaining on-time. If the relay state is continuously on for longer than the Output Time Limit, then relay will deactivate.

#### Output Details

The details for this type of output include the relay on/off state, HOA mode or Interlock status, total accumulated on-time, alarms related to this output, current cycle on time, remaining on-time, accumulator total, disturbance input value (if used) and adjusted target setpoint (if disturbance input is used), cycles of concentration, relay type and the current control mode setting.

#### Settings

Touch the Settings icon to view or change the settings related to the relay

<b>Target</b>	Enter the desired PPM set point for the product.
<b>Pump Capacity</b>	Enter the maximum flow rate for the metering pump.
<b>Pump Setting</b>	Enter the stroke length setting for the metering pump, in percent.
<b>Specific Gravity</b>	Enter the specific gravity of the product to be added.
<b>Accumulator Volume</b>	Enter the volume of water passing through the water meter to trigger the chemical feed.
<b>Flow Input</b>	Select the flow meter to be used as an input for this control relay.
<b>Flow Input 2</b>	Select the second flow meter, if any, to be used as an input for this control relay.
<b>Cycles Input</b>	Select the virtual input that is programmed as a Ratio calculation of the system conductivity/makeup conductivity, or select None.
<b>Low Cycles Limit</b>	Enter the lower limit for cycles of concentration, if used. The calculated on-time is limited to a maximum value if the cycles of concentration gets too low.
<b>Disturbance Input</b>	Select the virtual input or control output that will multiplied by the control setpoint (Target ppm setpoint). A typical application for this is to use a corrosion sensor as the disturbance input to adjust the PPM setpoint.
<b>Daily Max Time</b>	<p>Enter the maximum amount of accumulated on-time, in Hand or Auto modes, that the relay can have between midnight and midnight the next day. If the time is exceeded, the relay will deactivate, and a Daily Max Timeout alarm will be triggered. The alarm will clear, and relay allowed to reactivate at midnight the next day.</p> <p>If the relay was in Hand mode when the alarm was triggered, it will revert to whichever HOA state it was in prior to being set to Hand.</p> <p>To override the Daily Max Limit for the rest of the day, press Reset Output Timeout.</p>

### 5.3.20 Relay, PPM by Volume Control Mode

ONLY AVAILABLE IF HVAC MODE IS ENABLED. NOT AVAILABLE FOR VIRTUAL OUTPUTS.

#### Overview

In PPM by Volume control mode, the controller monitors the total volume of flow through up to two analog or digital flow meters, and after a programmable volume has been accumulated, the relay activates until the calculated number of pulses from a flow monitoring device to achieve a target PPM level are received.

The user enters the target PPM, the volume of water to trigger the chemical feed, and the data necessary to calculate the volume of chemical required to maintain the target PPM in that volume of water. The Feed Monitoring device programming (volume/pulse, assignment of the device to a relay output) is entered in the Feed Monitor digital input menus.

$$\text{Volume to Feed (gal or l)} = \frac{\text{Accumulated Volume (gal or l)} \times \text{Target PPM}}{\text{Cycles} \times \text{Specific Gravity} \times 10^6}$$

$$\text{Volume to Feed (l)} = \frac{\text{Accumulated Volume (m}^3\text{)} \times \text{Target PPM}}{(\text{Cycles} \times \text{Specific Gravity} \times 10^6) \times 1000}$$

#### Control Operation

As flow accumulates, the controller updates a field called Accumulator Total. When this value is greater than or equal to the value set for the Accumulator Volume, the relay activates for the calculated number of pulses from the feed monitor, and the accumulated total is reduced by the accumulator volume amount.

If the trigger volume is achieved again before the activation time has expired, the newly calculated feed monitor

pulses per unit volume are added to the remaining number. If the relay state is continuously on for longer than the Output Time Limit, then relay will deactivate.

### Output Details

The details for this type of output include the relay on/off state, HOA mode or Interlock status, total accumulated on-time, alarms related to this output, current cycle on time, remaining feed volume, accumulator total, cycles of concentration, relay type and the current control mode setting.

### Settings

Touch the Settings icon to view or change the settings related to the relay

<b>Target</b>	Enter the desired PPM set point for the product.
<b>Specific Gravity</b>	Enter the specific gravity of the product to be added.
<b>Accumulator Volume</b>	Enter the volume of water passing through the water meter to trigger the chemical feed.
<b>Flow Input</b>	Select the flow meter to be used as an input for this control relay.
<b>Flow Input 2</b>	Select the second flow meter, if any, to be used as an input for this control relay.
<b>Cycles Input</b>	Select the virtual input that is programmed as a Ratio calculation of the system conductivity/makeup conductivity, or select None.
<b>Low Cycles Limit</b>	Enter the lower limit for cycles of concentration, if used. The calculated on-time is limited to a maximum value if the cycles of concentration gets too low.
<b>Daily Max Time</b>	<p>Enter the maximum amount of accumulated on-time, in Hand or Auto modes, that the relay can have between midnight and midnight the next day. If the time is exceeded, the relay will deactivate, and a Daily Max Timeout alarm will be triggered. The alarm will clear, and relay allowed to reactivate at midnight the next day.</p> <p>If the relay was in Hand mode when the alarm was triggered, it will revert to whichever HOA state it was in prior to being set to Hand.</p> <p>To override the Daily Max Limit for the rest of the day, press Reset Output Timeout.</p>

## 5.3.21 Relay, Mass Balance Control Mode

ONLY AVAILABLE IF HVAC MODE IS ENABLED

### Overview

In Mass Balance control mode, the controller monitors the total volume of flow through up to two analog or digital flow meters, and after a programmable volume has been accumulated, the relay activates for a calculated time to achieve the desired product level. The user enters the product level, the volume of water to trigger the chemical feed, and the data necessary to calculate the pump on-time required to maintain the desired product level in that volume of water. A performance input may be selected, normally corrosion, to trim the desired product level setting based on that input reading.

$$\text{Pump On-Time (sec.)} = \frac{\text{Accumulator Setpoint (gal or l)} \times \text{Product Level} \times 0.0036}{\text{Cycles} \times \text{Pump Rating (gal or l/hr.)} \times \text{Pump Setting (\%)} \times \text{Specific Gravity (g/cm}^3\text{)}}$$

$$\text{Pump On-Time (sec.)} = \frac{\text{Accumulator Setpoint (m}^3\text{)} \times \text{Product Level} \times 3.6}{\text{Cycles} \times \text{Pump Rating (l/hr)} \times \text{Pump Setting (\%)} \times \text{Specific Gravity (g/cm}^3\text{)}}$$

### Control Operation



As flow accumulates, the controller updates a field called Accumulator Total. When this value is greater than or equal to the value set for the Accumulator Setpoint, the relay activates for the calculated number of seconds, and the accumulated total is reduced by the Accumulator Setpoint amount.

If the trigger volume is achieved again before the activation time has expired, the newly calculated on-time per unit volume is added to the remaining on-time. If the relay state is continuously on for longer than the Output Time Limit, then relay will deactivate.

### Output Details

The details for this type of output include the relay on/off state, HOA mode or Interlock status, total accumulated on-time, alarms related to this output, current cycle on time, remaining on-time, accumulator total, performance input value (if used) and adjusted target setpoint (if performance input is used), cycles of concentration, relay type and the current control mode setting.

### Settings

Touch the Settings icon to view or change the settings related to the relay

<b>Product Level</b>	Appears if no Performance Input has been selected. Enter the desired PPM set point for the product.
<b>Min Product Level</b>	Appears if a Performance Input has been selected. Enter the lowest desired PPM set point for the product.
<b>Max Product Level</b>	Appears if a Performance Input has been selected. Enter the highest desired PPM set point for the product.
<b>Min Trim Input</b>	Appears if a Performance Input has been selected. Enter the value of the trim input that will result in the minimum product level set point being used.
<b>Max Trim Input</b>	Appears if a Performance Input has been selected. Enter the value of the trim input that will result in the maximum product level set point being used.
<b>Pump Rating</b>	Enter the maximum flow rate for the metering pump.
<b>Pump Setting</b>	Enter the stroke length setting for the metering pump, in percent.
<b>Specific Gravity</b>	Enter the specific gravity of the product to be added.
<b>Accumulator Setpoint</b>	Enter the volume of water passing through the water meter to trigger the chemical feed.
<b>Flow Input</b>	Select the flow meter to be used as an input for this control relay.
<b>Flow Input 2</b>	Select the second flow meter, if any, to be used as an input for this control relay.
<b>Cycles Input</b>	Select the virtual input that is programmed as a Ratio calculation of the system conductivity/makeup conductivity, or select None.
<b>Low Cycles Limit</b>	Appears if a Cycles Input has been selected. Enter the lower limit for cycles of concentration, if used. The calculated on-time is limited to a maximum value if the cycles of concentration gets too low.
<b>Performance Input</b>	Select the input that will be used to trim the product level set point. A typical application for this is to use a corrosion sensor as the performance input to adjust the PPM setpoint.

## 5.3.22 Relay, Counter Timer Control Mode

ONLY AVAILABLE IF HVAC MODES ARE DISABLED IN CONFIG MENU – GLOBAL SETTINGS

The Counter Timer algorithm activates the relay for a programmable amount of time, triggered by the accumulation of a programmable number of contact closures from a Digital Counter type input.

### Output Details

The details for this type of output include the relay on/off state, HOA mode or Interlock status, time on, remaining on-time, accumulator total, total relay activation time, alarms related to this output, relay type and the current control mode setting.

### Settings

Touch the Settings icon to view or change the settings related to the relay.

<b>Feed Duration</b>	Enter the amount of time for the relay to activate for once the accumulated setpoint number of contact closures has been reached.
<b>Accumulated Setpoint</b>	Enter the number of contact closures required to trigger the relay activation.
<b>Input</b>	Select the input to be used to control this output.
<b>Daily Max Time</b>	<p>Enter the maximum amount of accumulated on-time, in Hand or Auto modes, that the relay can have between midnight and midnight the next day. If the time is exceeded, the relay will deactivate, and a Daily Max Timeout alarm will be triggered. The alarm will clear, and relay allowed to reactivate at midnight the next day.</p> <p>If the relay was in Hand mode when the alarm was triggered, it will revert to whichever HOA state it was in prior to being set to Hand.</p> <p>To override the Daily Max Limit for the rest of the day, press Reset Output Timeout.</p>

### 5.3.23 Relay Output, On/Off Disturbance Control Mode

On/Off control mode is enhanced to add a disturbance input that is multiplied by the user-entered setpoint. An example of this might be the control of a corrosion inhibitor containing PTSA based upon a fluorometer sensor input, with the setpoint modified based upon a corrosion sensor Disturbance Input, so a higher corrosion reading results in more corrosion inhibitor being fed. Another example might be cooling tower conductivity control on cycles of concentration, with the cycles setpoint modified by a Disturbance Input of Makeup Conductivity.

#### Output Details

The details for this type of output include the relay on/off state, HOA mode or Interlock status, accumulated on-time, alarms related to this output, current cycle on time, input value, current setpoint, disturbance input value, relay type, and the current control mode setting.

#### Settings

Touch the Settings icon to view or change the settings related to the relay.

<b>Set point</b>	Enter the sensor process value at which the relay will activate.
<b>Deadband</b>	Enter the sensor process value away from the set point at which the relay will deactivate.
<b>Duty Cycle Period</b>	<p>Using a duty cycle helps to prevent overshooting the set point in applications where the response of the sensor to chemical additions is slow. Specify the amount of time for the cycle, and the percentage of that cycle time that the relay will be active. The relay will be off for the rest of the cycle, even if the set point has not been satisfied.</p> <p>Enter the length of the duty cycle in minutes:seconds in this menu. Set the time to 00:00 if use of a duty cycle is not required.</p>
<b>Duty Cycle</b>	Enter the percentage of the cycle period that the relay will be active. Set the percentage to 100 if use of a duty cycle is not required.
<b>On Delay Time</b>	Enter the delay time for relay activation in hours:minutes:seconds. Set the time to 00:00:00 to immediately activate the relay
<b>Off Delay Time</b>	Enter the delay time for relay deactivation in hours:minutes:seconds. Set the time to 00:00:00 to immediately deactivate the relay
<b>Input</b>	Select the sensor to be used by this relay.
<b>Direction</b>	Select the control direction.
<b>Disturbance Input</b>	Select the virtual input or analog output to be multiplied by the control setpoint.

<b>Daily Max Time</b>	<p>Enter the maximum amount of accumulated on-time, in Hand or Auto modes, that the relay can have between midnight and midnight the next day. If the time is exceeded, the relay will deactivate, and a Daily Max Timeout alarm will be triggered. The alarm will clear, and relay allowed to reactivate at midnight the next day.</p> <p>If the relay was in Hand mode when the alarm was triggered, it will revert to whichever HOA state it was in prior to being set to Hand.</p> <p>To override the Daily Max Limit for the rest of the day, press Reset Output Timeout.</p>
-----------------------	--

### 5.3.24 Relay Output, Volumetric Blending Control Mode

Volumetric Blending is used to mix two liquid streams together at a fixed ratio. The relay controls a diverter valve that alternates between two sources, metering in a programmable accumulator volume when the relay is deactivated, and then switches to a programmable blend volume when the relay is activated.

This control mode includes an optional disturbance input that is multiplied by the user-entered blend volume. A common example is to mix two cooling tower makeup water sources, and then to use the makeup conductivity as a disturbance input to adjust the ratio.

#### Output Details

The details for this type of output include the relay on/off state, HOA mode or Interlock status, accumulated on-time, alarms related to this output, relay type, and the current control mode setting.

#### Settings

Touch the Settings icon to view or change the settings related to the relay.

<b>Accumulator Volume</b>	Enter the volume through the flow meter with the relay deactivated.
<b>Blend Volume</b>	Enter the volume through the flow meter with the relay activated.
<b>Flow Input</b>	Select the flowmeter input to be used to control this output.
<b>Disturbance Input</b>	Select the virtual input or analog output to be used to multiplied by the control setpoint (Blend Volume).
<b>Daily Max Time</b>	<p>Enter the maximum amount of accumulated on-time, in Hand or Auto modes, that the relay can have between midnight and midnight the next day. If the time is exceeded, the relay will deactivate, and a Daily Max Timeout alarm will be triggered. The alarm will clear, and relay allowed to reactivate at midnight the next day.</p> <p>If the relay was in Hand mode when the alarm was triggered, it will revert to whichever HOA state it was in prior to being set to Hand.</p> <p>To override the Daily Max Limit for the rest of the day, press Reset Output Timeout.</p>

### 5.3.25 Relay, Dual Switch Control Mode

Dual Switch mode is typically used to fill or empty a tank, using a level switch contact closure to activate the relay when the liquid level is at one extreme and deactivate the relay at the other extreme. It is more versatile than that; the on and off triggers may be any digital input or relay output state.

Note that the Dual Switch control relay will only respond to trigger relay state changes that occur when that relay is in Auto mode, not if the trigger is activated manually using Hand or Off modes.

#### Output Details

The details for this type of output include the relay on/off state, HOA mode Interlock or delay status, current cycle on time, time on over the past 24 hours, the total accumulated on-time since the last reset, alarms related to this

output, relay type, and the current control mode setting.

## Settings

Touch the Settings icon to view or change the settings related to the relay.

<b>On Switch</b>	Select the digital input or output that will trigger the relay to activate.
<b>Activate On</b>	Select the state of the digital input or output that will trigger the relay to activate.
<b>On Delay Time</b>	Enter the delay time for relay activation in hours:minutes:seconds. Set the time to 00:00:00 to immediately activate the relay.
<b>Off Switch</b>	Select the digital input or output that will trigger the relay to de-activate.
<b>Activate Off</b>	Select the state of the digital input or output that will trigger the relay to deactivate.
<b>Off Delay Time</b>	Enter the delay time for relay deactivation in hours:minutes:seconds. Set the time to 00:00:00 to immediately deactivate the relay.
<b>Daily Max Time</b>	<p>Enter the maximum amount of accumulated on-time, in Hand or Auto modes, that the relay can have between midnight and midnight the next day. If the time is exceeded, the relay will deactivate, and a Daily Max Timeout alarm will be triggered. The alarm will clear, and relay allowed to reactivate at midnight the next day.</p> <p>If the relay was in Hand mode when the alarm was triggered, it will revert to whichever HOA state it was in prior to being set to Hand.</p> <p>To override the Daily Max Limit for the rest of the day, press Reset Output Timeout.</p>

### 5.3.26 Relay, Boolean Logic Control Mode

In Boolean Logic control mode, the output is activated based on the state of two inputs, using AND, OR, or Inverse operators. The inputs to the algorithm can be the state of relay or virtual outputs, as well as the state of digital or remote Modbus digital inputs. If more than two state inputs are necessary, a virtual Boolean output can be used as an input to another Boolean control relay.

#### Output Details

The details for this type of output include the relay on/off state, HOA mode Interlock or delay status, current cycle on time, time on over the past 24 hours, the total accumulated on-time since the last reset, alarms related to this output, relay type, and the current control mode setting.

## Settings

Touch the Settings icon to view or change the settings related to the relay.

<b>Operation</b>	Select the operation to use to activate the relay. Choices are Input 1 AND Input 2, Input 1 OR Input 2, and Inverse Input.
<b>Input 1</b>	Select the digital input or output that will be used as Input 1 in the Operation used to trigger the relay to activate.
<b>Activate</b>	Select the state of the digital input (open or closed) or output (on or off) that will be used as Input 1 in the Operation used to trigger the relay to activate.
<b>Input 2</b>	Not available for Inverse Operation. Select the digital input or output that will be used as Input 2 in the Operation used to trigger the relay to activate.
<b>Activate</b>	Not available for Inverse Operation. Select the state of the digital input (open or closed) or output (on or off) that will be used as Input 2 in the Operation used to trigger the relay to activate.
<b>On Delay Time</b>	Enter the delay time for relay activation in hours:minutes:seconds. Set the time to 00:00:00 to immediately activate the relay.

<b>Off Delay Time</b>	Enter the delay time for relay deactivation in hours:minutes:seconds. Set the time to 00:00:00 to immediately deactivate the relay.
<b>Alarm</b>	Select if activation or deactivation of the Boolean Logic output should produce an alarm or not.
<b>Daily Max Time</b>	<p>Enter the maximum amount of accumulated on-time, in Hand or Auto modes, that the relay can have between midnight and midnight the next day. If the time is exceeded, the relay will deactivate, and a Daily Max Timeout alarm will be triggered. The alarm will clear, and relay allowed to reactivate at midnight the next day.</p> <p>If the relay was in Hand mode when the alarm was triggered, it will revert to whichever HOA state it was in prior to being set to Hand.</p> <p>To override the Daily Max Limit for the rest of the day, press Reset Output Timeout.</p>

### 5.3.27 Relay or Analog Output, Lag Control Mode

NOT AVAILABLE FOR VIRTUAL OUTPUTS

#### Overview

The Lead Lag control mode allows a group of outputs to be controlled by a single control algorithm using a variety of configurations. The control mode support backup pumps operation, alternate pump with wear leveling, and the activation of additional outputs after a time delay, or based on alternate set points, or based on digital state changes.

A Lead Lag group consists of a single Lead output and one or more Lag outputs. The Lead output can be set to any control mode. The new Lag control mode can be selected for any number of additional outputs (limited only by the number of outputs available within the controller). A setting for each Lag output allows selection of a Lead output that is used to create an ordered group of Lead Lag relays.

Example: R1 is an On/Off relay, R2 is set for Lag mode with a Lead output of R1. R3 is set as an additional Lag mode relay with a Lead output of R2, thus creating an ordered chain of three relays in the Lead Lag group (R1←R2←R3). After the group is defined, the Lead output (R1) operates with the standard On/Off Control functionality. The last Lag mode relay in the chain (R3) offers various settings that are used to define the desired control operations for the entire Lead Lag group. Selectable Lead Lag control options include backup, wear leveling, and/or activating additional outputs based on various criteria.

#### Backup Pump Control

By default, Lead Lag groups always provide backup operation if the Lead control mode determines that its output should be energized but it is disabled due to a Flow Verify alarm and/or because the Lead output HOA setting is Off or Hand (not in Auto mode).

#### Wear Leveling Modes

The order of Lead and Lag output activation can be changed based on configurable wear leveling modes. This option is intended to allow users to manage the usage of primary and secondary pumps within a system. One wear leveling mode selects a different output each time the group is activated. Additional modes vary the activation of the pumps within the group based on the time-on for each output, with the intent to either balance the usage of each pump or to energize the primary output most often and periodically exercise auxiliary pumps to insure proper operation when they are needed.

#### Output Activation Modes

Depending on the control mode selected for the Lead output, Lag output(s) can be configured for activation of additional outputs based on one or more of the following criteria:

On-time (for example, energize a second relay 10 minutes after the primary relay is turned on)

Control set points (for example, energize a second relay if the pH continues to rise)

Switch change (for example, energize a second pump to maintain a tank level when the low-low level switch opens)

## Control Operation

### Backup Pump Control

The default control operation for the Lead Lag group is that if a condition exists that prevents one relay from being activated, it is skipped and the next output in the group is turned on instead. This situation may occur if the output is experiencing an active Flow Verify alarm or the output is not in Auto mode. Backup control using a Lag output does not require any additional settings and could be used to create an output for a backup pump to be activated only if the main pump loses prime and/or is taken out of service for maintenance.

Example: A Lead Lag group consisting of R1, R2 & R3 is configured (R1←R2←R3). All three pumps have PosiFlow monitors wired to inputs D1, D2 & D3, respectively. R1 uses On/Off mode to control caustic feed to maintain a pH set point above 7.0. R1 and R3 pumps are in Auto mode, R2 pump has been taken out of service for maintenance and is currently in HOA Off mode. The process pH falls below 7.0 and R1 is energized. Before the pH rises to satisfy the dead band, the D1 PosiFlow input monitors an error condition and activates a Flow Verify alarm for the R1 pump. The Lead Lag system de-energizes R1 and checks the status of R2. Because R2 is not in service, R3 is energized to maintain caustic feed.

Each digital input channel set up as a Feed Monitor type has a Flow Alarm Mode setting used to specify how the pump output is handled when Flow Verify alarms are identified. Based on this setting, the Lead Lag group responds as follows:

<b>Disabled</b>	The Flow Verify alarm is never activated and the Lead Lag group is not affected by the status of the PosiFlow input.
<b>Interlock</b>	When a Flow Verify alarm is activated, the related output is immediately turned off; if available, other outputs in the Lead Lag group are activated instead.
<b>Maintain</b>	When a Flow Verify alarm is activated, other outputs in the Lead Lag group are activated instead if they are available; if no other outputs are available, or if additional outputs are required due to Output Activation Mode settings, output(s) reporting a Flow Verify alarm may still be activated as a last resort.

### Wear Leveling Modes

After the Lead Lag group is defined, additional parameters can be configured within the settings list of the last output in the group. These options optimize the behavior of the Lead Lag functionality. Several different wear leveling options can be selected to control the order in which outputs are activated.

#### Disabled

The order in which the Lead and Lag outputs turn on does not change automatically. They are always energized in the same order.

#### Duty Based

The order in which outputs are activated changes every time the Lead output is activated. How long each individual pump has been running is not considered.

Example: When the Lead output, set for On/Off control, drops below the setpoint, R1 is activated. R1 turns off after its deadband is satisfied. The next time the measurement goes below the setpoint, R2 is activated and R1 remains off. After all outputs in the group have been exercised for one feed cycle, the process begins again with the first output (R1).

#### Time Balanced

Time balanced mode alternates outputs in a manner that equalizes the runtime of all connected pumps. This mode takes into account how long each output in the Lead Lag group has been running (since a manual reset) and selects the output that has the lowest on-time during each cycle. If the output remains energized longer than the specified cycle time, the time-on for each output is recalculated and a different output may be activated to balance the usage of each.

*Example: In a two-pump Lead Lag group, time balanced wear leveling is selected with a cycle time of 2 hours.*

When the Lead control mode (R1) determines the output should be activated, R2 turns on because it has the lowest accumulated on-time. After 2 hours, if the output remains activated, the on-times are re evaluated and R2 turns off and R1 turns on because it now has the least accumulated total on time. The cycle continues until the Lead control mode determines the feed is complete.

### Time Unbalanced

This wear leveling mode improves fault-tolerance of the group by varying the wear on each pump by activating each pump for a different percentage of time. In this mode, a primary output is activated most of the time and secondary (auxiliary) output(s) are activated for a smaller percentage of the total output on-time. This strategy can be useful to ensure that a backup pump is exercised sufficiently so that it will be functional when needed, but does not wear at the same rate as the primary pump to minimize the chances of both pumps failing at the same time. When one Lag pump is defined within the Lead Lag group, the Lead pump runs 60% of the time and the Lag pump runs 40%. If more than two (2) pumps are defined for the group, fixed ratios are used to insure all pumps are exercised periodically and wear at different rates, as shown in the chart.

Percent On Relay	Number of Relays				
	2	3	4	5	6
1	60.0%	47.4%	41.5%	38.4%	36.5%
2	40.0%	31.6%	27.7%	25.6%	24.4%
3		21.1%	18.5%	17.1%	16.2%
4			12.3%	11.4%	10.8%
5				7.6%	7.2%
6					4.8%

### Output Activation Modes

Depending on the current control mode selection for the Lead output, additional settings may be available within the settings list of the last output in the group to provide additional option(s) to optimize the behavior of the Lead Lag functionality. Several different activation modes can be selected to control the status of additional output(s) based on either elapsed time, alternate setpoints, and/or alternate switch inputs.

#### Disabled

No action is taken to activate more than one output within the Lead Lag group of outputs. This mode is used when a group of Lead Lag outputs exists only to provide backup in case of a Flow Verify failure on one of the pumps, or if a pump is taken out of service, and/or if only wear leveling is desired.

#### Time Based

Lag outputs are activated following the Lead output after a user-settable delay. The same delay value is used for all outputs. This menu selection is available only when the Lead output is using On/Off, Dual Setpoint, Spike or Manual control modes.

*Example: If the Lead output is set to Manual, this control option could be used to force on the output based on a digital input signal (e.g., level switch). If the level switch remains open for more than the specified delay time, the second output in the Lead Lag group is energized. If another delay time elapses, a third output (if available) is also turned on.*

In On/Off, Dual Setpoint, or Spike control modes, additional pump(s) are energized if the process value remains outside the setpoint range for more than the specified delay time.

*Example: In a two-output Lead Lag group (R1←R2), the Lead (R1) output, set for Dual Setpoint control, is programmed to energize its output when the D.O. reading is outside the 4.0-4.5 ppb control range with a deadband of 0.1 ppb. Time based output activation is selected with a delay time of 15 minutes. When the D.O. value falls below 4.0 ppb, R1 is activated. After 15 minutes, if the D.O. has not risen to 4.1 ppb or higher, R2 will also be activated. When the process value reaches 4.1 ppb, both outputs are turned off.*

#### Setpoint Based

Each Lag output has its own setpoint(s) and deadband when this option is selected. The setpoints for each output in the Lead Lag group are evaluated individually and outputs are added as needed based on the current process value. Setpoint based activation mode also incorporates time based activation and can also be configured to trigger an additional pump (if available) after a specified delay time. This menu selection is available only when the Lead output is using On/Off or Dual Setpoint control modes.

*Example 1: The Lead output (R1) is set for On/Off control of pH with a setpoint of 8.50, a deadband of 0.20 and a “force lower” control direction. The first Lag output (R2) has a setpoint of 9.00 and a deadband of 0.20. The second Lag output (R3) has a setpoint of 9.50 and a deadband of 0.20. The delay time is disabled (set for 0:00 minutes). Wear leveling is disabled. When the pH goes above 8.50, R1 energizes. If the pH proceeds to exceed 9.00, R2 energizes. And if the pH rises above 9.50, R3 energizes. When the pH decreases to below 9.30, R3 goes off. When the pH falls to below 8.80, R2 goes off. And finally, when the pH decreases to below 8.30, R1 is turned off.*

*Example 2: The same three-pump configuration (R1←R2←R3) as in Example 1 except the delay time is set for 30 minutes. When the pH goes above 8.50, R1 energizes. If 30 minutes passes before the pH exceeds 9.00 or drops below 8.30, R1 remains on and R2 is energized. If the pH then rises above 9.00, the next output in the group, R3, is energized. If the pH continues to rise and exceeds 9.50, no additional action is possible. When the pH decreases to below 8.80, R3 goes off. When the pH falls to below 8.30, both R1 and R2 are turned off.*

This control is very similar to the operation if three (3) separate On/Off control outputs are configured all with the pH as Input and using the setpoints listed above. However, the Lead Lag option improves on this control by incorporating backup pump controls and optional time based activation. If the pH rises above 8.50 when pump R1 has an active Flow Verify alarm or is in HOA Off mode, pump R2 immediately energizes. R3 energizes when the pH goes above 9.00. Although no third pump is available to activate if the pH continues to rise above 9.50, this control system is more fault tolerant than the currently available options.

### **Switch Based**

When using switch based activation mode, each Lag output has an Activate With Channels setting that is used to specify one or more digital input or relay output channels that activates an additional output. Switch based activation mode incorporates time based activation and can also be configured to trigger an additional output (if available) after a specified delay time. This menu selection is available only when the Lead output is using Manual control mode.

*Example 1: A lift station includes a tank with a high level switch (D1) and a high-high level switch (D2). Three pumps are configured as a Lead Lag group (R1←R2←R3). The Lead output (R1) is set for Manual control mode with an Activate With Channels selection of D1 (high level switch), R1 will be energized if D1 closes. The first Lag output (R2) has an Activate With Channels selection of D2 (high-high level switch). The last Lag output (R3) has no Activate With Channels selected. All pumps are in HOA Auto mode. The delay time is disabled (set for 0:00 minutes). Wear leveling is disabled. When the high level switch closes, the R1 pump is activated. If the high-high level switch closes, the R2 pump is also activated. When D2 opens, R2 is turned off. When D1 opens, R1 is turned off. In this configuration, the R3 pump serves only as a backup in case one of the pumps is down for maintenance (in HOA Off mode).*

*Example 2: The same lift station, two-level switches, three-pump configuration (R1←R2←R3) as in Example 1 except the delay time is set for 1 hour. When the high level switch closes, the R1 pump is activated. If the high-high level switch closes, the R2 pump is also activated. If the tank level remains above the high-high level switch for another 1 hour, the R3 pump is activated. When D2 opens, R3 is turned off. When D1 opens, both R2 and R1 are turned off. In this configuration, the R3 pump serves not only as a backup in case one of the pumps is down for maintenance, but also provides additional capacity should it be needed.*

### **Advanced Functionality**

The examples listed above detail the control behavior if wear leveling or output activation modes are enabled. The features are implemented independently. Wear Leveling modes are used to determine which output(s) are activated. Output Activation modes determine how many output(s) are activated at one time. More advanced output control strategies can be implemented when these features are used in combination.

*Example: In a two-pump scenario, the Lead output (R1) is set for On/Off control of pH with a setpoint of 8.50,*



deadband of 0.20 and a “force lower” control direction. The Lag output (R2) has a setpoint of 9.00 and a deadband of 0.20. Time unbalanced (60/40) wear leveling is selected with a cycle time of 15 minutes. When the pH goes above 8.50, the on-times for each pump are evaluated. If R1 has been on less than 80% of the total time for the two pumps, it is energized. Otherwise, R2 has been on for less than 20% of the total time, so it is energized. If the pH remains above the deadband and does not exceed the second setpoint ( $8.30 < \text{pH} < 9.00$ ), the pump selection is re-evaluated every 15 minutes and, if warranted, the pump in operation is switched. If the pH proceeds to exceed 9.00, both pumps are energized and wear leveling is no longer a consideration. When the pH fails to below 8.80, the pump on-times are again evaluated and the appropriate pump is turned off.

Note that while this control is quite powerful, it might cause confusion with users because the setpoints entered for a specific pump within the Lead Lag group may not coincide with the setpoints used to activate that particular pump during operation. The information shown on the Details pages for each pump should be sufficient to minimize this ambiguity.

### Control Mode Conflicts

Some control modes are incompatible with Lag output functionality because of an interactive relationship between the output and one or more linked inputs:

- Intermittent Sampling – This control mode places a linked sensor into a Hold state during most of its operational cycle
- Probe Wash – This control mode places one or two linked sensors into a Hold state when a wash cycle is in progress and for a specified Hold period afterward

The link between the output and the sensor input(s) cannot be easily transferred to other outputs, so these types of control modes cannot be designated as Lead output for a Lead Lag group. Outputs configured with these types of control modes are not included on the selection list presented for Lead output. Also, the control mode of an output that is the Lead output for a Lead Lag group cannot be changed to one of these types. If selected, the controller will be unable to save the change and an error message will be added to system log.

### Output Details

The details for this type of output include the relay on/off state, relay status (HOA mode, Interlock from sensor calibration, probe wash, or other condition), the current cycle and the total on-times, alarms related to this output, the output defined as the Lead of the group, the output that is the Last Lag output of the group, the number of outputs currently energized within the group, the elapsed time since the last change in the number of outputs energized, the elapsed time since the last wear leveling evaluation, the type of output, and the current control mode setting.

### Settings

Touch the Settings icon to view or change the settings related to the relay.

The Lag control mode output defined as the Last Lag within the Lead Lag group offers settings to define the parameters controlling operation of the entire group.

All Lag mode outputs that are not the Last Lag output in the Lead Lag group (those that are selected as a Lead output from another Lag mode output) offer a more limited list of settings.

Lag Settings (Menus with \* are shown only in the Last Lag output settings)

<b>HOA Setting</b>	Select Hand, Off or Auto mode by touching the desired mode
<b>Lead</b>	Select the output that will be the lead output for this relay
<b>Wear Leveling*</b>	Select the wear leveling scheme to use. Refer to the detailed description above.
<b>Wear Cycle Time*</b>	This setting only appears if Time Balanced or Time Unbalanced Wear Leveling has been selected above. Enter the amount of elapsed time before time on totals for each output are reevaluated for wear leveling.
<b>Activation Mode*</b>	This entry is only appears if the control mode of the Lead output is On/Off, Dual Setpoint, Spike or Manual. Select one of the options that will determine if and when an additional output will be activated if the primary output is unable to reach the setpoint.

<b>Set point</b>	This setting only appears if the control mode of the Lead output is On/Off or Dual Setpoint and the Activation Mode above is Setpoint Based. Enter the process value for the input assigned to the Lead output that will trigger an additional output to activate.
<b>Set point 2</b>	This setting only appears if the control mode of the Lead output is Dual Setpoint and the Activation Mode above is Setpoint Based. Enter the process value for the input assigned to the Lead output that will trigger an additional output to activate.
<b>Deadband</b>	This setting only appears if the control mode of the Lead output is On/Off or Dual Setpoint and the Activation Mode above is Setpoint Based. Enter the sensor process value away from the set point(s) at which the relay will deactivate.
<b>Delay Time*</b>	This setting only appears if the control mode of the Lead output is On/Off, Dual Setpoint, Spike or Manual. Enter the amount of time, if any, to delay the activation of the output.
<b>Activate With Channels</b>	This setting only appears if the control mode of the Lead output is Manual and the activation mode is Switch Based. Select one or more digital input and/or relay output channels that, if activated, will also activate the Lag output
<b>Reset Time Total</b>	Enter this menu to clear the accumulated time that the output has been activated. This value is used for Time Balanced or Time Unbalanced wear leveling.
<b>Output Time Limit</b>	Enter the maximum amount of time that the relay can be continuously activated. Once the time limit is reached, the relay will deactivate until the Reset Output Timeout menu is entered.
<b>Reset Output Timeout</b>	Enter this menu to clear an Output Timeout alarm and allow the relay to control the process again.
<b>Name</b>	The name used to identify the relay may be changed.
<b>Mode</b>	Select the desired control mode for the output.

Several standard settings that are available for most control modes are not available for Lag outputs. These features affect the entire Lead Lag group and can be specified only within the Lead output's settings. The settings for these fields are propagated down through the entire Lead Lag group when changed for the Lead output. Although the settings for these fields are identical for all outputs in the Lead Lag group, the handling by each Lag output may be independent or group-managed.

Below are the settings that are in the Lead Relay settings that will affect the Lead Lag group:

<b>Interlock Channels</b>	Select the relays and digital inputs that will interlock this relay and all others in the group.
<b>Min Relay Cycle</b>	Enter the number of seconds that will be minimum amount of time that each relay in the group will be in the active or inactive state. Normally this will be set to 0, but if using a motorized ball valve that takes time to open and close, set this high enough that the valve has time to complete its movement.
<b>Hand Time Limit</b>	Enter the amount of time that each relay in the group will activate for when it is in Hand mode.
<b>Hand Output</b>	This menu only appears for pulse relay or analog output Lead outputs. Enter the output % desired for each output in the group when the output is in Hand mode.

<b>Off Mode Output</b>	This menu only appears for analog output Lead outputs. Enter the output mA value desired for each output in the group when the output is in Off mode, or being Interlocked, or during a calibration of the sensor being used as an input. The acceptable range is 0 to 21 mA.
<b>Error Output</b>	This menu only appears for analog output Lead outputs. Enter the output mA desired for each output in the group when the sensor is not giving the controller a valid signal. The acceptable range is 0 to 21 mA.

The *Activate With Channels* setting, normally available for all outputs, is **not** propagated through the Lead Lag group. This field can be entered independently for each Lag Output when the control mode of the Lead output is Manual and the activation mode is Switch Based.

Most other settings for the various types of Lead control modes are managed independently from other outputs within a Lead Lag group. In most cases, no *Activation Mode* settings are available, so the Lead output determines the status for the entire group based on its settings and the current controller parameters. However, when an Activation Mode is enabled, the handling of some settings may require some additional explanation. For example,

- Duty Cycle - If a Lead output with a control mode of On/Off or Dual Setpoint has a Duty Cycle setting of less than 100%, this cycle will be managed for the Lead output only. The Duty Cycle will drive other Lag outputs for Backup or Wear Leveling purposes. However, if additional Lag Output(s) are energized due to Setpoint-Based or Time-Based Activation Mode settings, the additional outputs will operate independently of the Duty Cycle setting. The Lead output will continue to cycle On and Off, however, the additional outputs will remain activated with 100% duty cycle until the setpoint deadband is satisfied.
- On Delay / Off Delay - If the Lead output with a control mode of On/Off, Dual Setpoint, or Manual has either an On or Off Delay Time setting specified, the delay will be managed for the Lead output only. If one or more Lag outputs provide Backup or Wear Leveling support, the Delay Times would also effect these outputs. However, if additional Lag Output(s) are energized due to Activation Mode settings, the additional outputs will operate independently of the On or Off Delay Time setting(s) and will energize and de-energize without delay when needed.

### 5.3.28 Relay Output, Flow Meter Ratio Control Mode

ONLY AVAILABLE IF HVAC MODES ARE ENABLED IN CONFIG MENU – GLOBAL SETTINGS

Flow Meter Ratio Control Mode is typically used in cooling water applications to control the conductivity of the water using volumetric cycles of concentration. The controller measures the volume of makeup water going through one or two water meters, and after a programmable amount, activates the relay to control a programmable volume out through one or two bleed water meters.

#### Output Details

The details for this type of output include the relay on/off state, HOA mode or Interlock status, Accumulated make-up water total, bleed cycle volume, remaining volume, relay on-time for this cycle, accumulated on-time, alarms related to this output, relay type, and the current control mode setting.

#### Settings

Touch the Settings icon to view or change the settings related to the relay.

<b>Accumulator Volume</b>	Enter the volume through the makeup water meters that will activate the relay.
<b>Bleed Volume</b>	Enter the volume through the bleed water meters that will deactivate the relay.
<b>Makeup Meter</b>	Select the makeup water meter from the pulldown list.
<b>Makeup Meter 2</b>	Select the makeup water meter from the pulldown list, if applicable, or leave at None.
<b>Bleed Meter</b>	Select the bleed water meter from the pulldown list.
<b>Bleed Meter 2</b>	Select the bleed water meter from the pulldown list, if applicable, or leave at None.

<b>Daily Max Time</b>	<p>Enter the maximum amount of accumulated on-time, in Hand or Auto modes, that the relay can have between midnight and midnight the next day. If the time is exceeded, the relay will deactivate, and a Daily Max Timeout alarm will be triggered. The alarm will clear, and relay allowed to reactivate at midnight the next day.</p> <p>If the relay was in Hand mode when the alarm was triggered, it will revert to whichever HOA state it was in prior to being set to Hand.</p> <p>To override the Daily Max Limit for the rest of the day, press Reset Output Timeout.</p>
-----------------------	--

### 5.3.29 Relay or Analog Output, Disturbance Variable Control Mode

Only available for 4-20 mA and pulse relay output channels.

These control modes generate an output by combining contributions from a Primary control output, a Disturbance Input, and a Trigger Input in a variety of ways. When the disturbance trigger discrete input is active, the disturbance input is multiplied by the primary output to determine the control percent output. An alternate calculation trigger mode selection (Use Disturbance) is available to simply switch to the disturbance output when the trigger is active (rather than combine the two values).

#### Some Example Applications

##### In-Line pH Control Adjusted for Flow

Direct feedback pH control in a pipe using a Primary Output of PID or Proportional control mode, with the Disturbance Input using flow rate to provide a multiplier to adjust the output. This is primary feedback control with a feedforward trim. No Trigger is required.

##### Chemical feed in proportion to Flow Adjusted for pH

If the incoming flow is variable but the pH of the water is relatively constant, feed the chemical using Mass Balance control mode, with the Disturbance Input using the pH reading to provide a multiplier to adjust the output. This is primary feedforward control with a feedback trim. No Trigger is required.

##### Alternate Control During Upset Condition

Some disturbance applications require switching from one control mode to a different control mode (or a similar mode with different control settings) during an upset condition. The Primary Output could be set to Proportional control of pH, with the Disturbance Input selected as a Mass Balance control algorithm. A Trigger Input could be selected as a relay output that activates if the flow rate is either too high or too low. These conditions would trigger a switch from pH control to flow based control.

#### Output Details

The details for this type of output include the % output, HOA mode or Interlock status, alarms related to this output, Primary Output %, Disturbance Input value, current cycle on-time, accumulated on-time, raw output (in mA or pulses/min.), relay type, and the current control mode setting.

#### Settings

Touch the Settings icon to view or change the settings related to the relay.

<b>Minimum Output</b>	Enter the lowest output %. If the output should be off at the set point, this will be 0%.
<b>Maximum Output</b>	Enter the highest output %.
<b>Hand Output</b>	Enter the output % desired when the output is in Hand mode.
<b>Off Mode Output</b>	Only for analog outputs. Enter the output mA value desired when the output is in Off mode, or being Interlocked, or during a calibration of the sensor being used as an input. The acceptable range is 0 to 21 mA.

<b>Maximum Rate</b>	Only for pulse outputs. Enter the maximum pulse rate that the metering pump is designed to accept (10 - 360 pulse/minute range).
<b>Error Output</b>	Only for analog outputs. Enter the output mA desired when the sensor is not giving the controller a valid signal. The acceptable range is 0 to 21 mA.
<b>Primary Output</b>	Select the control output that will be used along with the disturbance input to calculate the control signal for the disturbance output.
<b>Disturbance Input</b>	Select the virtual input or analog output that will be used along with the Primary Output to calculate the control signal for the disturbance output.
<b>Trigger Input</b>	Select a state-type digital input or relay output that will be used to initiate the disturbance control, or select None if the disturbance control will be active all the time.
<b>Activated</b>	Only appears if the Trigger Input is other than None. If a digital input is the Trigger Input, select between When Open or When Closed. If a relay output is the Trigger Input, select between When On or When Off.
<b>Trigger Mode</b>	Only appears if the Trigger Input is other than None. Select the action to take when the disturbance control algorithm has been activated. Multiply is used to calculate the control signal by multiplying the Disturbance Input value by the primary control output value. Use Disturbance is used when the Disturbance Input selected is a control output, and the action desired is to use this different control algorithm when in the disturbance state.

### 5.3.30 Analog Output, Proportional Control Mode

#### Output Details

The details for this type of output include the output %, HOA mode or Interlock status, accumulated on-time, alarms related to this output, current cycle on time, relay type and the current control mode setting.

#### Settings

Touch the Settings icon to view or change the settings related to the relay.

<b>Set point</b>	Enter the sensor process value at which the output % will be the programmed minimum %.
<b>Proportional Band</b>	Enter the sensor process value away from the set point at which the output % will be the programmed maximum %.
<b>Minimum Output</b>	Enter the lowest output %. If the output should be off at the set point, this will be 0%.
<b>Maximum Output</b>	Enter the highest output %.
<b>Hand Output</b>	Enter the output % desired when the output is in Hand mode.
<b>Off Mode Output</b>	Enter the output mA value desired when the output is in Off mode, or being Interlocked, or during a calibration of the sensor being used as an input. The acceptable range is 0 to 21 mA.
<b>Error Output</b>	Enter the output mA desired when the sensor is not giving the controller a valid signal. The acceptable range is 0 to 21 mA.
<b>Input</b>	Select the sensor input to use for proportional control.
<b>Direction</b>	Select the control direction.

### 5.3.31 Analog Output, Mass Balance Mode

#### Overview

In Analog Mass Balance control mode, the controller monitors the rate of flow through an analog or paddlewheel flow meter, and continuously adjusts the proportional band to achieve a target product level.

The user enters the target PPM product level and the data necessary to calculate the proportional band (the water flow rate at which the maximum pulse rate will occur) required to maintain the target PPM with that flow rate of water.

A performance input may be selected, normally corrosion, to trim the desired product level setting based on that input reading.

$$\% \text{ output} = \frac{\text{Target PPM} \times \text{Water Flow Rate (liter/min or gal/min)}}{\text{Cycles} \times \text{Pump Rating (liter or gal/hr)} \times \text{Pump Setting (\%)} \times \text{Specific Gravity} \times 166.67}$$

$$\% \text{ output} = \frac{\text{Target PPM} \times \text{Water Flow Rate (m}^3\text{/min)}}{\text{Cycles} \times \text{Pump Rating (liter/hr)} \times \text{Pump Setting (\%)} \times \text{Specific Gravity} \times 0.16667}$$

## Control Operation

If the output is continuously on for longer than the Output Time Limit, then output will deactivate.

## Output Details

The details for this type of output include the output %, HOA mode or Interlock status, alarms related to this output, current cycle on time, total accumulated on-time, cycles of concentration, mA output, and the current control mode setting.

## Settings

Touch the Settings icon to view or change the settings related to the relay.

<b>Target</b>	Appears if no Performance Input has been selected. Enter the desired PPM set point for the product.
<b>Min Product Level</b>	Appears if a Performance Input has been selected. Enter the lowest desired PPM set point for the product.
<b>Max Product Level</b>	Appears if a Performance Input has been selected. Enter the highest desired PPM set point for the product.
<b>Min Trim Input</b>	Appears if a Performance Input has been selected. Enter the value of the trim input that will result in the minimum product level set point being used.
<b>Max Trim Input</b>	Appears if a Performance Input has been selected. Enter the value of the trim input that will result in the maximum product level set point being used.
<b>Pump Rating</b>	Enter the maximum flow rate for the metering pump.
<b>Pump Setting</b>	Enter the stroke length setting for the metering pump, in percent.
<b>Specific Gravity</b>	Enter the specific gravity of the product to be added.
<b>Hand Output</b>	Enter the output % desired when the output is in Hand mode.
<b>Off Mode Output</b>	Enter the output mA value desired when the output is in Off mode, or being Interlocked, or during a calibration of the sensor being used as an input. The acceptable range is 0 to 21 mA.
<b>Error Output</b>	Enter the output mA desired when the sensor is not giving the controller a valid signal. The acceptable range is 0 to 21 mA.
<b>Flow Input</b>	Select the flow meter to be used as an input for this control relay.
<b>Cycles Input</b>	Select the virtual input that is programmed as a Ratio calculation of the system conductivity/makeup conductivity, or select None.
<b>Low Cycles Limit</b>	Appears if a Cycles Input has been selected. Enter the lower limit for cycles of concentration, if used. The calculated on-time is limited to a maximum value if the cycles of concentration gets too low.
<b>Performance Input</b>	Select the input that will be used to trim the product level set point. A typical application for this is to use a corrosion sensor as the performance input to adjust the PPM setpoint.

### 5.3.32 Analog Output, PID Control Mode

ONLY AVAILABLE IF CONTROLLER INCLUDES ANALOG OUTPUT HARDWARE & HVAC MODE IS DISABLED

The PID algorithm controls an analog (4-20 mA) output using standard Proportional-Integral-Derivative control logic. The algorithm provides feedback control based on an error value continuously calculated as the difference between a measured process variable and a desired set point. Tuning settings specify the response for proportional (the size of the error), integral (the time that the error has been present), and derivative (the rate of change for the error) parameters. With proper tuning, the PID control algorithm can hold the process value close the set point while minimizing overshoot and undershoot.

#### Normalized Error

The error value versus set point that is calculated by the controller is normalized and represented as percent of full scale. As a result, tuning parameters entered by the user are not dependent upon the scale of the process variable and the PID response with similar settings will be more consistent even when using different types of sensor inputs.

The scale used to normalize the error is dependent upon the type of sensor selected. By default, the full nominal range of the sensor is used. This range is editable by the user if tighter control is desired.

#### PID Equation Formats

The controller supports two different forms of the PID equation as specified by the Gain Form setting. The two forms require different units for entry of the PID tuning parameters.

##### Standard

The standard form is more commonly used in industry because its time-based settings for the integral and derivative coefficients are more meaningful. This form is selected by default.

Parameter	Description	Units
$K_p$	Gain	unitless
$T_i$	Integral Time	seconds or seconds/repeat
$T_d$	Derivative Gain	seconds

$$Output (\%) = K_p \left[ e(t) + \frac{1}{T_i} \int e(t)dt + T_d \frac{de(t)}{dt} \right]$$

Parameter	Description	Units
$e(t)$	Current Error	% of full scale
$dt$	Delta Time Between Readings	seconds
$de(t)$	Difference Between Current Error & Previous Error	% of full scale

##### Parallel

The parallel form allows the user to enter all parameters as Gains. In all cases, larger gain values result in faster output response. This form is used in the WebMaster controller and is used internally by the Control Module.

Parameter	Description	Units
$K_p$	Proportional Gain	unitless
$K_i$	Integral Gain	1/ seconds
$K_d$	Derivative Gain	seconds

$$Output (\%) = K_p e(t) + K_i \int e(t)dt + K_d \frac{de(t)}{dt}$$

## Integral Value Management

To determine the integral component of the PID calculation, the controller software must maintain a running total of the accumulated area under the error curve (Current Integral). The sign of the value added to the accumulated Current Integral during each cycle may be positive or negative based on the current Direction setting as well as the relative values of the current process reading and the set point.

### Override Control

The Current Integral accumulates when the output is set to Auto mode. If the controller is switched to Off mode, the value no longer accumulates, but it is not cleared. Therefore, PID control will resume where it left off if the controller is switched from Off back to Auto. Similarly, accumulation of the Control Integral will be suspended if the output is interlocked and resume after the lock-out is removed.

### Bumpless Transfer

When the output is switched from Hand to Auto mode, the controller calculates a value for the Current Integral using the current error to generate the same output percent as the Hand Output setting. This calculation does not use the Derivative tuning setting to minimize errors from momentary fluctuations in the input signal. This feature ensures a smooth transition from manual to automatic control with minimal overshoot or undershoot as long as the user sets the Hand Output percentage close to the value that the process is expected to require for optimal control in Auto mode.

### Wind-up Suppression

The Current Integral value that is accumulating while the output is set to Auto can become very large or very small if the process value remains on the same side of the set point for a prolonged period of time. However, the controller may not be able to continue to respond if its output is already set to the minimum or maximum limits (0-100% by default). This condition is referred to as Control Wind-Up and can result severe overshoot or undershoot after a prolonged upset has ended.

For example, if the process value remains far below the set point despite a control output being pinned at 100%, the Current Integral will continue to accumulate errors (wind-up). When the process value finally rises to above the set point, negative errors will begin to decrease the Current Integral value. However, the value may remain large enough to keep the output at 100% long after the set point is satisfied. The controller will overshoot the set point and the process value will continue to rise.

To optimize system recovery after wind-up situations, the controller suppresses updates to the Current Integral that would drive the output beyond its minimum or maximum limit. Ideally, the PID parameters will be tuned and the control elements (pump, valves, etc.) will be sized properly so that the output never reaches its minimum or maximum limit during normal control operations. But with this wind-up suppression feature, overshoot will be minimized should that situation occur.

### Output Details

The details for this type of output include the analog output value in %, HOA mode or Interlock status, input value, current integral, current and accumulated on-times, alarms related to this output, and the current control mode setting.

<b>Set Point</b>	Numeric entry of a process value used as a target for PID control. The default value, units and display format (number of decimal places) used during data entry are defined based on the Input channel setting selected.
<b>Gain</b>	When the Gain Form setting is Standard, this unitless value is multiplied by the total of the proportional, integral, and derivative terms to determine the calculated output percent.
<b>Proportional Gain</b>	When the Gain Form setting is Parallel, this unitless value is multiplied by the normalized error (current process value versus set point) to determine the proportional component of the calculated output percent.
<b>Integral Time</b>	When the Gain Form setting is Standard, this value is divided into the integral of the normalized error (area under the error curve), then multiplied by the Gain to determine the integral component of the calculated output percent.
<b>Integral Gain</b>	When the Gain Form setting is Parallel, this value is multiplied by the integral of the normalized error (area under the error curve) to determine the integral component of the calculated output percent.



<b>Derivative Time</b>	When the Gain Form setting is Standard, this value is multiplied by the change in error between the current reading and the previous reading, then multiplied by the Gain to determine the derivative component of the calculated output percent.
<b>Derivative Gain</b>	When the Gain Form setting is Parallel, this value is multiplied by the change in error between the current reading and the previous reading to determine the derivative component of the calculated output percent.
<b>Reset PID Integral</b>	The PID Integral Value is a running total of the accumulated area under the error curve (Current Integral). When this menu option is selected, this total is set to zero and the PID algorithm is reset to its initial state.
<b>Minimum Output</b>	Enter the lowest possible output value (normally 0%).
<b>Maximum Output</b>	Enter the highest possible output value as a percentage.
<b>Off Mode Output</b>	Enter the output mA value desired when the output is in Off mode, or being Interlocked, or if the Output Time Limit has expired, or during a calibration of the sensor being used as an input. Also if there is a Probe Wash programmed for the sensor, and the Sensor Mode option is set to Disable the output during the Wash cycle (if the Sensor Mode option is set to Hold the output holds its last setting and the Integral is not updated during the Wash). The acceptable range is 0 to 21 mA.
<b>Error Output</b>	Enter the output mA desired when the sensor is not giving the controller a valid signal. The acceptable range is 0 to 21 mA.
<b>Input</b>	Select the sensor to be used by this output.
<b>Direction</b>	Set the control direction. This setting is used to determine the sign of the calculated error (current process value versus set point) and allows flexible control with only positive values for all PID tuning parameters.
<b>Input Minimum</b>	The low end of the sensor input range, used to normalize errors into percent of full scale units. These values are set to the nominal range of the selected input sensor by default.
<b>Input Maximum</b>	The high end of the sensor input range, used to normalize errors into percent of full scale units. These values are set to the nominal range of the selected input sensor by default.
<b>Gain Form</b>	Select the PID Equation Format used to enter tuning parameters.

### 5.3.32 Analog Output, Manual Mode

#### Output Details

The details for this type of output include the analog output %, HOA mode or Interlock status, accumulated on-time, alarms related to this output, current cycle on time, and the current control mode setting.

#### Settings

A Manual analog output will activate if the HOA mode is Hand, or if it is Activated With another channel. There are no additional programmable parameters

### 5.3.33 Analog Output, Retransmit Mode

#### Output Details

The details for this type of output include the output %, HOA mode or Interlock status, accumulated on-time, alarms related to this output, current cycle on time, relay type and the current control mode setting.

#### Settings

Touch the Settings icon to view or change the settings related to the relay.

<b>4 mA Value</b>	Enter the process value to correspond to a 4 mA output signal.
<b>20 mA Value</b>	Enter the process value to correspond to a 20 mA output signal.
<b>Hand Output</b>	Enter the output % desired when the output is in Hand mode.

<b>Error Output</b>	Enter the output % desired when the input signal is invalid (Error mode).
<b>Input</b>	Select the sensor input to retransmit.



## 5.4 Configuration Menu

The configuration Settings Menu is used for settings and activities that are not tied to Inputs or Outputs.

### 5.4.1 Global Settings

<b>Date</b>	Enter the current year, month and day.
<b>Time</b>	Enter the current hour (military time), minute, and second.
<b>Name</b>	Enter the name to help identify the controller when it connects to Fluent.
<b>Location</b>	Enter the location to help identify the controller when it connects to Fluent.
<b>Global Units</b>	Select the units to be used for cable length and wire gauge settings, metric or Imperial.
<b>Temperature Units</b>	Select between Fahrenheit and Celsius.
<b>Alarm Delay</b>	Enter how much time to wait after powering up the controller before alarm conditions are considered valid.
<b>HVAC Modes</b>	Enable HVAC Modes for cooling tower and boiler applications where the relay control modes for Biocide timer, Bleed and Feed, Bleed then Feed, and Intermittent Sampling are required. Disable HVAC Modes if these control modes are not necessary and a more generic timer control mode will replace the Biocide timer.
<b>Language</b>	Select the language the software will use.

### 5.4.2 Security Settings

<b>Controller Log Out</b>	When Security is Enabled, and after the password has been entered, the controller requires immediate use of a password to calibrate or change settings. Once finished making changes, log out to prevent unauthorized changes by someone else. If not manually logged out, the controller will automatically log out after 10 minutes of inactivity.
<b>Security</b>	Select Enable to require a password in order to calibrate or change settings, or Disable to allow calibration and set point changes without a password. In order to enable security, the default password must be entered first, then touch Enabled, then touch the Confirm icon.
<b>Local Password</b>	Used to change the touchscreen password needed for full configuration capability if security has been enabled. The default local password is 5555. This can and should be changed using this menu if Security is enabled.

### 5.4.3 Ethernet Settings

Will not appear if a WiFi-Only type WiFi card is installed.

<b>DHCP Setting</b>	Select Enabled to get an IP address from the LAN or Disabled to use a fixed IP address.
<b>Controller IP Address</b>	Enter the default IP address to use if a network is not available or if DHCP is disabled.
<b>Network Netmask</b>	Enter the default netmask to use if a network is not available or if DHCP is disabled.
<b>Network Gateway</b>	Enter the default gateway address to use if a network is not available or if DHCP is disabled.
<b>DNS Server</b>	Enter the default DNS server IP address to use if DHCP is disabled.
<b>Web Page Color Scheme</b>	Select between the Light color background and the Dark color background
<b>Fluent Alarm Delay</b>	Enter the number of minutes to delay in sending out a Fluent Comms Error message if a data packet is not successfully sent. In order to delay at all, the time must exceed the Update Period time.

<b>TCP Timeout</b>	Do not change from the default of 1 second unless directed to by technical service. The TCP Timeout should only be increased if the Fluent live connection is being Reset due to slow cellular connection speed.
<b>Fluent Status</b>	Select Enabled to activate a connection to Fluent, or Disabled to stop sending data and alarms to Fluent.
<b>LiveConnect Status</b>	Select Enabled to allow the ability to access the controller programming and log files remotely using Fluent, or Disabled to prevent remote connection to the controller using Fluent. The controller can still send data and alarms to Fluent, but the LiveConnect icon will not appear on the Fluent webpages.
<b>Update Period</b>	Enter the time between data updates being sent to Fluent.
<b>Reply Timeout</b>	Enter the maximum time allowed for Fluent to respond.

#### 5.4.4 Ethernet Details

The Ethernet Details are for information only and display the Ethernet settings currently in use, and the recent history of the Fluent connection. Will not appear if a WiFi-Only type WiFi card is installed.

<b>Alarms</b>	Displays any active Ethernet-related alarms
<b>DHCP Status</b>	Displays if the connection to the LAN using DHCP was successful or not.
<b>Controller IP Address</b>	Displays the IP address that the controller is currently using.
<b>Network Netmask</b>	Displays the netmask address that the controller is currently using.
<b>Network Gateway</b>	Displays the gateway address that the controller is currently using.
<b>DNS Server</b>	Displays the DNS server address that the controller is currently using.
<b>MAC Address</b>	Displays the MAC address of the Ethernet card.
<b>Last Fluent Config</b>	Displays the date and time of the last attempt to send configuration data to the Fluent server.
<b>Last Fluent Data</b>	Displays the date and time of the last attempt to send a data to the Fluent server.

#### 5.4.5 WiFi Settings

Will only appear if a WiFi option board is installed.

There are two types of WiFi board that are available.

The WiFi-only type of board will disable the controller's wired Ethernet connection when it is attached to the controller. The controller will either be able to connect to a Local Area Network (LAN) via Infrastructure Mode, or it will be able to connect to a PC, tablet, or cell phone via Ad-Hoc Mode. It will not be able to have a wired Ethernet connection to a LAN or cellular gateway device and also connect to a tablet via Ad-Hoc Mode. This configuration is inherently more secure.

The dual connection type WiFi cards do not disable the controller's wired Ethernet connection when it is attached to the controller. This allows simultaneous connection to a cellular gateway (Ethernet) and a LAN (WiFi, using Infrastructure mode), or to a LAN (Ethernet) and a nearby PC, tablet or cell phone (WiFi, using Ad-Hoc mode). This configuration is inherently less secure, since it cannot be guaranteed to be impossible to bridge between the two connections.

<b>WiFi Mode</b>	Select between Infrastructure Mode, Ad-Hoc Mode, or Disabled.
<b>SSID</b>	Infrastructure Mode. Enter the SSID of the LAN's wireless network connection.
<b>Key</b>	Infrastructure Mode. Enter the key needed to connect to the LAN's wireless network connection.

<b>Gateway Connection</b>	<p>Infrastructure Mode. Only appears if a Dual WiFi/Ethernet type WiFi card is installed. Select which connection, Ethernet or WiFi, will provide the Gateway function. This means that all external Internet connections such as Fluent or emails will default to using this connection.</p> <p>Note that If the selected connection is no longer available, the controller will switch to using the other connection. Regardless of the connection being used , the menus to enable or disable Fluent or Live Connect will be available only in the selected connection’s menu.</p>
<b>DHCP Setting</b>	Infrastructure Mode. Enable to allow the controller to obtain its IP address and other network settings from the LAN or disable to enter this information manually.
<b>Controller IP Address</b>	Infrastructure Mode. Only appears if a Dual WiFi/Ethernet type WiFi card is installed, and the DHCP Setting is set to Disabled. Manually enter the IP address for the controller.
<b>Network Netmask</b>	Infrastructure Mode. Only appears if a Dual WiFi/Ethernet type WiFi card is installed and the DHCP Setting is set to Disabled. Manually enter the network netmask address for the controller.
<b>Network Gateway</b>	Infrastructure Mode. Only appears if a Dual WiFi/Ethernet type WiFi card is installed and the Gateway Connection is selected as WiFi, and the DHCP Setting is set to Disabled. Manually enter the gateway address to be used by the controller when connected to the LAN.
<b>DNS Server</b>	Infrastructure Mode. Only appears if a Dual WiFi/Ethernet type WiFi card is installed and the Gateway Connection is selected as WiFi, and the DHCP Setting is set to Disabled. Manually enter the address for the DNS server that the controller will use.
<b>Ad-Hoc SSID</b>	Ad-Hoc Mode. Enter the SSID that the controller may broadcast as an available wireless network connection. The default setting is “ControllerModel_SerialNumber”
<b>Ad-Hoc Security</b>	Ad-Hoc Mode. Select the security protocol used by the controller’s wireless network connection.
<b>Ad-Hoc Key</b>	Ad-Hoc Mode. Enter the key needed to connect to the controller’s wireless network connection. Between 8 and 64 characters are required.
<b>SSID Broadcast</b>	Ad-Hoc Mode. Select whether the controller’s wireless network card will broadcast its SSID or not.
<b>TCP Timeout</b>	Do not change from the default of 1 second unless directed to by technical service. The TCP Timeout should only be increased if the Fluent live connection is being Reset due to slow cellular connection speed.
<b>Temporary Ad-Hoc</b>	Infrastructure Mode. Enable if it is desirable to allow the controller to disconnect from Infrastructure Mode and switch to a time-limited Ad-Hoc mode, to give a user temporary access to the controller without allowing that user access to the network.
<b>Begin/End Temporary Ad-Hoc Mode</b>	Infrastructure Mode. Only appears if Temporary Ad-Hoc is Enabled. Press this to start the temporary Ad-Hoc mode connection and timer. The menu will change to End Temporary Ad-Hoc Mode while the timer is running. Pressing the menu again will end the Ad-Hoc connection immediately. Otherwise the connection will end when it times out.
<b>Ad-Hoc Time Limit</b>	Infrastructure Mode. Only appears if Temporary Ad-Hoc is Enabled. Enter the time limit for the temporary ad-hoc mode connection.

## 5.4.6 WiFi Details

Will only appear if a WiFi option board is installed.

The WiFi Details are for information only and display the network settings currently in use.

<b>WiFi Status</b>	Displays if the WiFi is enabled or disabled.
<b>Signal Strength</b>	Displays the signal strength in the range of -100 to -30 dBm
<b>RSSI</b>	Displays the Relative Signal Strength In percent (0% = -100 dBm and 100% is greater than -49 dBm).
<b>WiFi Channel</b>	Displays the WiFi channel that the controller is currently using.
<b>Alarms</b>	Displays any active WiFi-related alarms.
<b>DHCP Status</b>	Displays if the connection to the device using DHCP was successful or not.
<b>Controller IP Address</b>	Displays the IP address that the controller is currently using.
<b>Network Netmask</b>	Displays the netmask address that the controller is currently using.
<b>Network Gateway</b>	Displays the gateway address that the controller is currently using.
<b>Security Protocol</b>	Displays the security protocol that the controller is currently using.
<b>DNS Server</b>	Displays the DNS server address that the controller is currently using
<b>BSSID/MAC Address</b>	Displays the BSSID/MAC address of the WiFi board.
<b>FCC ID</b>	Displays the FCC ID code, if applicable (USA).
<b>IC ID</b>	Displays the IC ID code, if applicable (Canada).
<b>Last Fluent Config</b>	Displays the date and time of the last attempt to send configuration data to the Fluent server.
<b>Last Fluent Data</b>	Displays the date and time of the last attempt to send a data to the Fluent server.
<b>Live Connect Status</b>	Displays the status of the Live Connect tunnel.

#### 5.4.7 Remote Communications (Modbus and BACnet)

This menu will appear only if one of the optional Remote Communications activation keys has been imported into the controller, either by the factory at the time of ordering, or later using a field activation file.

To add the Remote Communications feature in the field, purchase the activation key file and save it to a USB drive, as the only file stored on the root directory of the stick. Insert the stick into the USB port of the controller. Go to the Configuration Menu, then File Utilities, then Import User Config File. Press the Confirm icon to start the activation process.

The display will report whether the import was successful or not. The activation key file is only valid for the serial number of the controller for which it was purchased.

For a complete description of the Modbus feature and register map, refer to the separate Modbus instruction manual. For a complete description of the BACnet features that are supported refer to the separate BACnet Protocol Implementation Conformance Statement.

<b>Comm Status</b>	Select Modbus or BACnet to enable one of the protocols, or Disabled.
<b>Data Format</b>	Modbus Only. Select to receive Modbus data in Standard (Float) format or Float Inverse format
<b>Device ID</b>	BACnet Only. Enter the device ID for the controller. The default will be based on the controller serial number.
<b>Network</b>	BACnet only, if the dual connection WiFi card is installed. Select the connection that will be used for BACnet communications; Ethernet or WiFi.
<b>Data Port</b>	The standard port for Modbus data is port 502, and for BACnet is 47808. Enter the port used if it is non-standard.
<b>Verbose Logging</b>	If logging is Enabled, all Modbus or BACnet requests will be logged in the Event Log (any errors, the function called, starting register, number of registers, value of the first register, get object requests). This is useful when first setting up the HMI, but it will quickly fill the Event Log if it is not Disabled during normal operation. The Verbose Logging function will be automatically disabled after power to the controller is cycled.

## 5.4.8 Email Report Settings

NOTE: To set up the content of the Graph report, connect using a browser via Ethernet or WiFi and go to the Graph webpage. See section 6.

<b>Report #1 (through 4)</b>	Enter this menu to activate and set up a report to email, via the menus below:
<b>Report Type</b>	Select the type of report to email: None, Alarm, Datalog, Graph, or Summary (the Home webpage showing a Summary of current conditions).
<b>Email Recipients</b>	Select up to 8 email addresses that reports may be sent to by touching the check box. The addresses are entered in the Email Addresses menu described below.
<b>Repetition</b>	Only appears if Report Type is Datalog, Graph or Summary. Select how frequently to repeat sending the report: None, Hourly, Daily, Weekly or Monthly.
<b>Reports Per Day</b>	Only appears if Report Type is Datalog, Graph or Summary. Only appears if the repetition is set to Hourly. Select the number of reports per day: 2, 3, 4, 6, 8, 12 or 24. The report is sent on the Report Time and then evenly spaced throughout the day.
<b>Day</b>	Only appears if Report Type is Datalog, Graph or Summary. Only appears if the repetition is set to Weekly. Choose the day of the week on which the report will be sent.
<b>Day of Month</b>	Only appears if Report Type is Datalog, Graph or Summary. Only appears if the repetition is set to Monthly. Choose the day of the month on which the report will be sent. If the current month has less days than the number entered, the report will be sent on the last day of the month.
<b>Report Time</b>	Only appears if Report Type is Datalog, Graph or Summary. Only appears if the repetition is set to Daily, Weekly or Monthly. Enter the time of day for the report to be sent.
<b>Log Frequency</b>	Only appears if the Report Type is Datalog. Select the amount of time between data points. The amount of time allowed varies with the repetition of the report.
<b>Alarm Mode</b>	Only appears if Report Type is Alarm. Choose to send emails on All Alarms or only Selected Alarms.
<b>Attach Summary</b>	Only appears if Report Type is Alarm. Select Enabled to receive alarm emails that include the Main Menu webpage as an attachment or Disabled to receive a text-only alarm report email.
<b>Select Alarms</b>	Only appears if Report Type is Alarm. Only appears if the Alarm Mode is set to Selected Alarms. Select an Input or Output channel, System Alarm or Network Alarm, then touch the check box for individual alarms that will trigger an email to the list of recipients. Repeat for as many as desired.
<b>Alarm Delay</b>	Only appears if Report Type is Alarm. Enter how much time to wait after the alarm has been triggered before alarm conditions are considered valid and the email is sent.
<b>Email Addresses</b>	Enter up to 8 email addresses that reports may be sent to.
<b>Email Server</b>	Select the type of email server to be used: Walchem Fluent®, SMTP, ASMTMP, or TLS/SSL. Walchem Fluent and TLS/SSL will only be an available selection if the software version is 3.31 or higher (TLS/SSL) or 3.37 (Walchem Fluent). Refer to Config – Controller Details menu for the Network board software version.
<b>SMTP Server</b>	Will not appear if Email Server is Walchem Fluent. Enter the SMTP server address, either numeric or its name.
<b>SMTP Port</b>	Will not appear if Email Server is Walchem Fluent. Walchem Fluent email requires that port 49887 is open. Enter the port to be used by email server. The default is port 25 for SMTP, port 587 for ASMTMP, and port 465 for TLS/SSL.

<b>From Address</b>	Enter the controller's email address. If the email server selected is Walchem Fluent, only enter the portion of the address to be shown before the @ symbol. All emails will be from @ walchem-fluent.net
<b>ASMTTP Username</b>	Enter the username required for authentication. Only appears if the email server type is ASMTTP or TLS/SSL.
<b>ASMTTP Password</b>	Enter the password required for authentication. Only appears if the email server type is ASMTTP or TLS/SSL.
<b>Test Report Recipients</b>	Select the email addresses from the list that should receive the test report. If there are none, enter them in the Email Addresses menu described above.
<b>Send Email Test Report</b>	Enter this menu and confirm to send the test Summary report to the selected test report recipients.

### 5.4.9 Display Settings

<b>Home 1</b>	Select the input or output to display on the 1 <sup>st</sup> line of the display Home screen.
<b>Home 2</b>	Select the input or output to display on the 2 <sup>nd</sup> line of the display Home screen.
<b>Home 3</b>	Select the input or output to display on the 3 <sup>rd</sup> line of the display Home screen.
<b>Home 4</b>	Select the input or output to display on the 4 <sup>th</sup> line of the display Home screen.
<b>Home 5</b>	Select the input or output to display on the 5 <sup>th</sup> line of the display Home screen.
<b>Home 6</b>	Select the input or output to display on the 6 <sup>th</sup> line of the display Home screen.
<b>Home 7</b>	Select the input or output to display on the 7 <sup>th</sup> line of the display Home screen.
<b>Home 8</b>	Select the input or output to display on the 8 <sup>th</sup> line of the display Home screen.
<b>Adjust Display</b>	Change the contrast and the brightness by touching the arrow keys. If the display becomes unreadable, it is possible to reset the defaults by powering down and pressing the bottom right corner of the touchscreen while powering back on.
<b>Auto Dim Time</b>	If this is set to a non-zero time, the display backlight will dim if the touchscreen is not touched for that amount of time. Touching the screen will turn the back to normal brightness.
<b>Key Beep</b>	Select enable to hear a beep when an icon is pressed, or disable for silence

### 5.4.10 File Utilities

The File Utilities menu is used to transfer log files, user settings files and software upgrade files, using the local and a USB flash drive stick or using a network connection and browser.

If using a USB drive, it is necessary to choose a quality product, less than 16 MB capacity, with FAT file system.

Files may be renamed, but Configuration and Software Upgrade file extensions must NOT be changed. The USB drive must contain only one copy of these type of files. If more than one is available, the first one alphabetically will be imported by the controller.

<b>File Transfer Status</b>	Displays the status of the last attempt to export a file
<b>Data Log Export</b>	The data log contains data from every input and output. Enter this menu set up a data log file to export:
<b>Data Log Range</b>	Select how far back in time for data to be downloaded: Since Previous download, past 6 hours, all the way up to the past 3 months.
<b>Log Frequency</b>	Select the amount of time between data points. The amount of time allowed varies with the Data Log Range. If the Data Log Range is selected as Since Previous download, the choices for frequency of data points will be limited by how far back in time the last download occurred.

<b>Export Data Log File</b>	Save the Data Log file, as defined by the Data Log Range and Log Frequency settings above, to a USB stick.
<b>Periodic Log Export</b>	The periodic log contains data that is calculated hourly rather than analog in nature, such as hourly Minimum Maximum and Average sensor calculations, relay virtual output or digital input hourly on times, flow total volumes for the hour, and analog output average output % for the hour.  Enter this menu set up a periodic data log file to export:
<b>Periodic Log Range</b>	Select how far back in time for data to be downloaded: Since Previous download, past 6 hours, all the way up to the past 3 months.
<b>Log Frequency</b>	Select the amount of time between data points. The amount of time allowed varies with the Periodic Log Range. If the Periodic Log Range is selected as Since Previous download, the choices for frequency of data points will be limited by how far back in time the last download occurred.
<b>Export Periodic Log File</b>	Save the Periodic Log file, as defined by the Periodic Log Range and Log Frequency settings above, to a USB stick.
<b>Export Event Log</b>	Save the Event Log file to a USB stick. This records set point changes, user calibrations, alarms, relay state changes, file exports, etc.
<b>Export System Log</b>	Save the System Log file to a USB stick. This records hardware changes, software upgrades, automatic calibrations, power loss, system-level issues, etc.
<b>Export User Config File</b>	The User Configuration file contains all settings for the controller. Enter this menu to save the controller's settings to a USB stick (or download the file to a computer if using the web interface) for using later to restore settings to this controller, or to program additional controllers with the same settings as this one. It may take several minutes to create the file and transfer it.
<b>Import User Config File</b>	The User Configuration file contains all settings for the controller. Insert a USB stick (if using the local interface) containing the desired Configuration file. Enter this menu to import the file from the stick onto the controller. If using the web interface, click Upload and select the file to upload.
<b>Restore Default Config</b>	Enter this menu to restore all of the settings to the factory default values. Any changes to settings that were previously made will be lost!
<b>Software Upgrade</b>	Insert a USB stick that has the upgrade file stored in the root directory into the USB connector under the watertight cap on the outside of the front panel (see figure 19). Touch the Confirm icon, and then touch the Confirm icon to start the upgrade.

NOTE: To maintain the IP65 rating, always remove the stick and replace the cap securely over the USB connector when not in use.

### 5.4.11 Controller Details

<b>Controller</b>	Displays the name for the group of default settings used as built
<b>Product Name</b>	Displays the model of the controller as built
<b>Serial Number</b>	Displays the serial number of the controller
<b>Controller Board</b>	Displays the part number and revision of the front panel circuit board
<b>Software Version</b>	Displays the software version on the controller board
<b>Power Board</b>	Displays the part number and revision of the power/relay board
<b>Sensor Board #1 - #4</b>	Displays the part number and revision of the I/O boards (One entry for each board installed, up to 4)
<b>Software Version</b>	Displays the software version on each I/O board (One entry for each board installed, up to 4)
<b>Last Data Log</b>	Displays the date and time of the last data log download



<b>Digital Inputs</b>	Displays the part number and revision of the digital inputs
<b>Software Version</b>	Displays the software version of the digital inputs
<b>Network</b>	Displays the part number and revision of the network circuit
<b>Software Version</b>	Displays the software version on the network circuit
<b>Battery Power</b>	Displays the VDC output of the battery that is used to hold the date and time. The acceptable range is 2.4-3.3 VDC.
<b>Controller Temp 1</b>	Displays the temperature of the first controller thermistor. The acceptable range is -10 to 75 C.
<b>Controller Temp 2</b>	Displays the temperature of the second controller thermistor. The acceptable range is -10 to 75 C.
<b>Relay Board Temp</b>	Displays the temperature of the relay board thermistor. The acceptable range is -10 to 75 C.
<b>Processor Temp</b>	Displays the temperature of the controller board processor. The acceptable range is -10 to 75 C.
<b>DI Temp</b>	Displays the temperature of the digital input processor. The acceptable range is -10 to 75 C.
<b>I/O Card 1-4 Temp</b>	Displays the temperature of each I/O module processor. The acceptable range is -10 to 75 C.
<b>Network Temp</b>	Displays the temperature of the network circuit processor. The acceptable range is -10 to 85 C.
<b>+12 Volt Supply</b>	The normal range is 11.28 to 12.72 VDC. The 12 V supply is the main DC power from which all lower voltages are generated.
<b>+5 Volt Supply</b>	The normal range is 4.7 to 5.3 VDC. The 5 V supply is used for powering all the I/O.
<b>+3.3 Volt Supply</b>	The normal range is 2.8 to 3.5 VDC. The 3V supply is used to run the system.
<b>LCD Bias Voltage</b>	The normal range is -25 to -20 VDC. This is the touchscreen voltage after contrast adjustment.
<b>LCD Supply</b>	The normal range is -25 to -20 VDC. This is the touchscreen voltage before contrast adjustment.

## 5.5 HOA Menu



The HOA (Hand-Off-Automatic) Menu is used to quickly and easily test all relay outputs, and to stop or enable automatic control.

Touch the relay number in order to change the HOA state of that relay. The relay number will be shaded dark, and its current HOA state will be shaded dark. Then touch the desired state. The change happens immediately unless that relay has a Minimum Relay Cycle programmed that is above 0 seconds.



## 5.6 Graph Menu



The Graph Menu is used to display a graph containing one sensor or analog input value plus one digital input or relay state. Touch the Graph icon and the controller will display “Generating Graph Please Stand By” for a few seconds then show the graph. The default is to show the value of sensor input S11 and the state of relay output R1 over the past 10 minutes.

Touching any point on either line on the graphs displays a vertical line plus the details for that data point: date and time, value of the sensor, and an arrow showing if the state or the digital input/relay was high or low at that time.



Touching the  or the  icons will redraw the graph forward or backwards in time, in increments of one time range. It can only go back in time to the point where the data log file used to generate the graph starts. Changing the time frame while in the graph view, after moving back in time, shows data from that past time. Exiting the graph

menu and returning to the graph menu moves back to the current time.

## Settings

<b>Sensor</b>	Enter this menu to select the sensor, analog input, flowmeter type digital input (total flow and/or flow rate if applicable), or analog output value to show on the graph
<b>DI/Relay</b>	Enter this menu to select digital input, or analog output value to show on the graph
<b>Low Axis Limit</b>	The graph auto-scales based on the sensor value if both Low and High Axis Limit are set to 0. To manually adjust the Y axis scale, enter the low limit here.
<b>High Axis Limit</b>	The graph auto-scales based on the sensor value if both Low and High Axis Limit are set to 0. To manually adjust the Y axis scale, enter the high limit here.
<b>Time Range</b>	Select the time range for the X axis of the graph. The time range may also be accessed from the graph view by touching the time range icon in the lower right corner.

The resolution of the screen only allows for 84 data points per graph, so not all data points in each time range can be shown. For finer resolution, download the data log CSV file from the Config – File Utilities menu and graph the data in Excel or equivalent spreadsheet application.

<b>Time Range</b>	<b>Time between data points</b>	<b>Datalog file used</b>
10 minutes	10 seconds	Daily
30 minutes	30 seconds	Daily
1 hour	1 minute	Daily
2½ hours	2 minutes	Weekly
8 hours	6 minutes	Weekly
½ day	10 minutes	Weekly
1 day	20 minutes	Weekly
½ week	1 hour	Monthly
1 week	2 hours	Monthly
2 weeks	4 hours	Monthly
4 week	8 hours	Monthly

## 6.0 OPERATION using Ethernet

All of the same settings that are available using the touchscreen are also available using a browser that is connected to the controller’s Ethernet IP address. The controller may be connected to a Local Area Network (LAN), directly to the Ethernet port of a computer, or to the Fluent account management system server.

### 6.1 Connecting to a LAN

Connect the controller’s network card to the LAN using a CAT5 cable with RJ45 connector.

#### 6.1.1 Using DHCP

Using the touchscreen, from the Main menu, touch Config, then touch Ethernet Settings, then touch DHCP Setting. Touch Enabled, then the Confirm icon.

After a power cycle of the controller, return to Config, then Ethernet Details to view the Controller IP Address that has been assigned to the controller by the network.

#### 6.1.2 Using a fixed IP Address

Using the touchscreen, from the Main menu, touch Config, then touch Ethernet Settings, then touch DHCP Setting.

Touch Disabled, then the Confirm icon. Cycle power to the controller. If DHCP is already Disabled then you can skip this step.

Using the touchscreen, from the Main menu, touch Config, then touch Ethernet Settings, then touch Controller IP Address. Enter the IP address provided by the administrator of the LAN then touch the Confirm icon. Repeat for the Network Netmask and Network Gateway settings. Cycle power to the controller.

## 6.2 Connecting Directly to a Computer

Connect the controller's network card to the computer using a CAT5 cable with RJ45 connector.

Follow the instructions above to give the controller a fixed IP address that is compatible with the network settings of the computer. On the Security webpage there is also a setting for the Log in Timeout, which is the time limit for the web connection to be idle before requiring the user to log in again. Having this setting short is the best protection against unauthorized access.

Open a browser and type the numeric Controller IP address in the web page address field. The login screen should quickly appear. Once logged in, the Home page will appear.

The default username is admin and the default password is the 10-digit serial number for the controller. The serial number can be found printed on the label on the side of the controller, or by using the local touchscreen and going to the Config menu, then Controller Details.

Once logged in with the default password, a prompt will appear to change to new credentials. The option to close the prompt window and continue using the existing credentials exists, however the Admin and View-Only level usernames and passwords can and should be changed by browsing to the Config menu, Security Settings webpage. Log into the page using the current Admin level username and password, then change to new ones.

## 6.3 Navigating the web pages

From any computer that is directly connected to the controller, or is on the same network as the controller, open a browser and type the numeric Controller IP address in the web page address field. The login screen should quickly appear.

The default username is admin and the default password is the 10-digit serial number for the controller. The serial number can be found printed on the label on the side of the controller, or by using the local touchscreen and going to the Config menu, then Controller Details.

Once logged in with the default password, a prompt will appear to change to new credentials. The option to close the prompt window and continue using the existing credentials exists, however the Admin and View-Only level usernames and passwords can and should be changed by browsing to the Config menu, Security Settings webpage. Log into the page using the current Admin level username and password, then change to new ones.

After logging in, the Home page will appear. This will display the date and time, any active alarms, and the current readings or status of all of the Inputs and Outputs. On the left side of the page you will see links to the Main Menu selections: Alarms, Inputs, Outputs, Graphs, Config, Notepad and Software Upgrade if available. Click each menu to see the submenus, and click on the submenu to access all of the details and settings associated with it. At the bottom, there is a manual logout.

Below the Main Menu links there may be links to the instruction manual, Walchem website, and Walchem Fluent website, that are useful if the controller is connected to the Internet.

## 6.4 Graphs Webpage

The graphs page can display up to 8 parameters at a time. All possible parameters available based upon the controller programming are listed in one column. Click the right arrow to add the highlighted parameter to the Selected column, or the left arrow to move a selected parameter back out. Use the up and down arrows to move the highlighted selected

parameter up and down the list to set the order of the graphs on the page.

Click the Refresh Graph button



to display the changes.

Select the Time Range for the X-Axis of the graph from the pulldown list, from 1 Hour to 4 Weeks.

If you are setting up a Graph Report email, click Save For Report to set the current page settings as the ones to be used for the report. You will want to make sure that the selected Time Range is at least as long as the Report Frequency set in the Email Report menu.

You can then change the settings on the graphs webpage without changing the report settings, by clicking the refresh button without clicking the Save For Report button. The graph page will be greyed out until the refresh button has been clicked.

In order to see what the report settings are, click the Load Report Settings button.

The graph email will contain an html attachment showing the graphs. The Export Graph button can be used to save the graphs as an image that can be copied to a document. The same button is also available directly from the Graphs webpage.

The graphs will display the parameter's data in 360 data points, equally spread over the time range, in a blue line. For analog inputs and outputs, the minimum value, maximum value, and average value over that same time range are also displayed and graphed in a yellow line. The Y-axis will auto-scale to fit the data.

To change the Y-axis scale to a custom range, click anywhere on the axis, enter the desired minimum and maximum values, click Save, and then click the refresh graph button. To return to auto-ranging, click the Y-axis, click Set Defaults, and refresh.

## 6.5 Software Upgrade

The software upgrade link will appear only to users with Admin login, and only if the controller has access to the Internet with TCP port 9013 open inbound and outbound and the controller software is currently at version 3.31 or higher, and the software is not at the latest version available.

An Upgrade Description link to a webpage that supplies more details on the content of the upgrade is also available.

Click on Start Upgrade to begin the upgrade process.

The Upgrade Status will be displayed, with a button that may be used to Cancel the upgrade. Upon confirmation to cancel the upgrade, a Resume button will appear.

The status messages include:

Preparing controller for upgrade

Then if successful: Complete

Or not successful: Failed

Downloading upgrade file (showing number of bytes downloaded of total number of bytes)

Then if successful: Complete

Or not successful: Failed

Validating upgrade file

Then if successful: Complete

Or not successful: Failed

Upgrade in progress (showing each individual step in the upgrade installation)

When the upgrade installation is complete, the login webpage will appear. Status or error messages will be recorded in the System Log.

## 6.6 Notepad Menu



The Notepad Menu is used to store up to 10,240 bytes of notes (approximately one byte per character for English language). This is typically used to communicate or store important process changes or events. A byte counter in the lower right-hand corner displays how much space remains.

Click Save Notes and do not navigate away from the webpage until the popup screen indicates that changes have been accepted. If the size is too large, you can click Clear Notes, which is noted in the Event Log, or delete some text and then save.

## 6.7 Remote Sensor Calibration

For each sensor input, a Sensor Calibration is available on the input's webpage. To initiate a sensor calibration, click on the One-Point Process Calibration button.

A popup will open that displays the current value for that input and allow entry of the new value. Type the value of that parameter as determined by another meter or laboratory analysis and click Begin Calibration. Click Cancel to abort the calibration and retain the previous calibration.

For input types using automatic temperature compensation, the temperature reading will be displayed until the reading is stable and then move to the next step without any action required.

If successful, the calibration gain or offset will be displayed. Click Save to accept the new value or Cancel to retain the previous calibration.

If the new value results in a gain or offset that is out of the allowable range for the input, Calibration Failed will be displayed. Click OK to end the calibration and retain the previous calibration settings. Refer to section 8.1 Calibration Failure for help troubleshooting each type of sensor.

## 7.0 MAINTENANCE

---

The controller itself requires very little maintenance. Wipe with a damp cloth. Do not spray down the controller unless the enclosure door is closed and latched.

### 7.1 Electrode Cleaning

NOTE: The controller must be recalibrated after cleaning the electrode.

#### Frequency

The electrode should be cleaned periodically. The frequency required will vary by installation. In a new installation, it is recommended that the electrode be cleaned after two weeks of service. To determine how often the electrode must be cleaned, follow the procedure below.

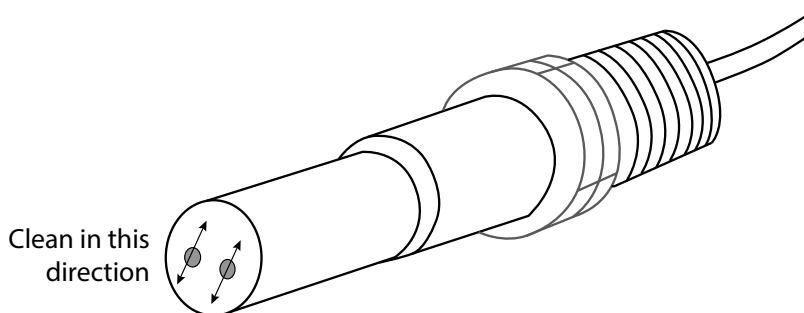
1. Read and record the conductivity.
2. Remove, clean and replace the conductivity electrode.
3. Read conductivity and compare with the reading in step 1 above.

If the variance in readings is greater than 5%, increase the frequency of electrode cleaning. If there is less than 5% change in the reading, the electrode was not dirty and can be cleaned less often.

#### Cleaning Procedure

The electrode can normally be cleaned using a cloth or paper towel and a mild detergent. If coated with scale, clean with a dilute (5%) solution of hydrochloric acid solution. Occasionally an electrode may become coated with various substances that require a more vigorous cleaning procedure. Usually the coating will be visible, but

not always. To clean a coated electrode, use fine grit abrasive, such as emery paper. Lay the paper on a flat surface and move the electrode in a back and forth motion. The electrode should be cleaned parallel to the carbon electrodes, not perpendicular.



**Figure 20 Cleaning the Electrode**

## 7.2 Replacing the Fuse Protecting Powered Relays



**CAUTION:** Disconnect power to the controller before opening front panel!

Locate the fuse on the circuit board at the back of the controller enclosure under the plastic safety cover. Gently remove the old fuse from its retaining clip and discard. Press the new fuse into the clip, secure the front panel of the controller and return power to the unit.

Warning: Use of non-approved fuses can affect product safety approvals. Specifications are shown below. To insure product safety certifications are maintained, it is recommended that a Walchem fuse be used.

<b>Fuse 5 x 20 mm, 6A, 250V</b>	<b>Walchem P/N 102834</b>
---------------------------------	---------------------------

## 8.0 TROUBLESHOOTING



**CAUTION:** Disconnect power to the controller before opening front panel!

Troubleshooting and repair of a malfunctioning controller should only be attempted by qualified personnel using caution to ensure safety and limit unnecessary further damage. Contact the factory.

### 8.1 Calibration Failure

Calibrations will fail if the adjustments to the reading are outside of the normal range for a properly functioning system. Refer to the instruction manual for the specific sensor being used for further information.

#### 8.1.1 Contacting Conductivity Sensors

The calibration will fail if the adjustment to the gain is outside of 0.5 to 2.0.

Possible Cause	Corrective Action
Dirty electrode	Clean electrode
Improper wiring of sensor to controller	Correct wiring
Wrong cell constant entered	Program the controller cell constant setting at the value that matches the electrode being used
Incorrect temperature reading or setting	Ensure that the temperature is accurate
Incorrect cable length or wire gauge setting	Set to the correct values
Faulty electrode	Replace electrode

### 8.1.2 Electrodeless Conductivity Sensors

The calibration will fail if the adjustment to the gain is outside of 0.2 to 10, or the offset is outside of -10,000 to 10,000.

Possible Cause	Corrective Action
Dirty sensor	Clean sensor
Improper wiring of sensor to controller	Correct wiring
Sensor placed too close to container walls	Relocate sensor
Sensor placed in the direct path of electrical current flow	Relocate sensor
Incorrect temperature reading or setting	Ensure that the temperature is accurate
Incorrect cable length or wire gauge setting	Set to the correct values
Faulty sensor	Replace sensor

### 8.1.3 pH Sensors

The calibration will fail if the adjustment to the gain is outside of 0.2 to 1.2, or if the calculated offset is outside of -140 to 140.

Possible Cause	Corrective Action
Dirty electrode	Clean electrode
Improper wiring of sensor to controller	Correct wiring
Incorrect temperature reading or setting	Ensure that the temperature is accurate
Incorrect cable length or wire gauge setting	Set to the correct values
Faulty electrode	Replace electrode
Faulty preamplifier	Replace preamplifier

### 8.1.4 ORP Sensors

The calibration will fail if the adjustment to the gain is outside of 0.5 to 1.5, or if the calculated offset is outside of -300 to 300.

Possible Cause	Corrective Action
Dirty electrode	Clean electrode
Improper wiring of sensor to controller	Correct wiring
Faulty electrode	Replace electrode
Faulty preamplifier	Replace preamplifier

### 8.1.5 Disinfection Sensors

The calibration will fail if the adjustment to the gain is outside of 0.2 to 10.0, or if the calculated offset is outside of -40 to 40.

Possible Cause	Corrective Action
Insufficient conditioning	Wait for the appropriate amount of time before attempting a calibration.
Insufficient sample flow	Increase flow rate to between 30 and 100 liter per hour.
Air bubbles on membrane	Dislodge bubbles. Adjust flow rate higher if necessary.
Air bubbles in electrolyte	Refill membrane cap with electrolyte.
Dirty membrane	Clean membrane
Loose membrane cap	Tighten membrane cap.
Faulty membrane	Replace membrane cap.
High Pressure	Reduce pressure to below 1 atmosphere and refill cap with electrolyte
No electrolyte fill solution in membrane cap	Fill membrane cap with electrolyte. Replace membrane cap if it will not hold solution.

Improper wiring of sensor to controller	Correct wiring
Faulty sensor	Replace sensor
Faulty analysis equipment or reagents	Consult test equipment instructions
Sample contaminated with interfering molecule refer to Sensitivity specification in sensor instructions)	Remove source of contamination

### 8.1.6 Analog Inputs

The calibration will fail if the adjustment to the gain is outside of 0.5 to 2.0, or if the calculated offset is outside of -2 to 2 mA.

Possible Cause	Corrective Action
Improper wiring of sensor to controller	Correct wiring
Faulty sensor	Replace sensor

### 8.1.7 Temperature Sensors

The calibration will fail if the calculated offset is outside of -10 to 10.

Possible Cause	Corrective Action
Improper wiring of sensor to controller	Correct wiring
Temperature input is set to the incorrect element	Reprogram to match the connected temperature element
Faulty sensor	Replace sensor

### 8.1.8 Corrosion Inputs

The calibration will fail if the corrosion rate or imbalance value entered is outside the range of 0 to 5 times the corrosion rate Range setting.

Possible Cause	Corrective Action
Improper wiring of sensor to controller	Correct wiring
Range settings is too low	Increase the Range setting
Electrode tips have not conditioned long enough	Allow time for electrodes to condition
Old electrodes	Replace electrodes and consider setting an Electrode Alarm reminder
Electrodes not tight	Tighten electrodes
Electrodes are not completely submerged	Install sensor in the side branch of a tee, not the top

## 8.2 Alarm Messages

### HIGH or HIGH-HIGH ALARM

Occurs if the sensor reading rises above the high alarm set points. If your unit is programmed for an alarm relay output, the alarm relay will activate. The controller will continue to check the sensor reading, and any outputs using the sensor will remain active.

Possible Cause	Corrective Action
The process went further out of control than normal.	May have to increase chemical flow rate.
The chemical supply has run out.	Replenish the chemical supply.
The pump or valve or supply line is faulty.	Repair or replace the control device.
Wrong chemical is being controlled.	Replace with correct chemical.
The sensor is not responding to changes.	Repair or replace sensor. Evaluate mixing or recirculation.
The pump is siphoning, valve leaking.	Repair or replace the control device or re-route tubing.
Control output has been left in "HAND" mode.	Switch back to "AUTO".
It may be a normal part of the process.	None required.



<b>LOW or LOW-LOW ALARM</b>	
<b>Occurs if the sensor reading drops below the low alarm set points. If your unit is programmed for an alarm relay output, the alarm relay will activate. The controller will continue to check the sensor reading, and any outputs using the sensor will remain active.</b>	
Possible Cause	Corrective Action
The process went further out of control than normal.	May have to increase chemical flow rate.
The chemical supply has run out.	Replenish the chemical supply.
The pump or valve or supply line is faulty.	Repair or replace the control device.
Wrong chemical is being controlled.	Replace with correct chemical.
The sensor is not responding to changes.	Repair or replace sensor. Evaluate mixing or recirculation.
The pump is siphoning, valve leaking.	Repair or replace the control device or re-route tubing.
Control output has been left in "HAND" mode.	Switch back to "AUTO".
It may be a normal part of the process.	None required.
<b>DEVIATION ALARM</b>	
<b>Occurs if there is a redundant sensor virtual input, and the two sensors assigned are reading too far apart.</b>	
Possible Cause	Corrective Action
The deviation alarm setting may be too low	Adjust setting
One or both of the sensors may need cleaning and calibration	Clean and calibrate
One of the sensors may be faulty	Replace sensor
<b>DI STATE CUSTOM MESSAGE</b>	
<b>A digital input that is a DI State type can be set such that either the open or closed state generates an alarm. The alarm message may be customized. The most common use for this will be a Flow Switch.</b>	
Possible Cause	Corrective Action
No flow	Check piping for closed valves, blockage, etc. Check recirculation pump.
Faulty flow switch/cable	Check with ohmmeter.
Faulty controller	Check by shorting digital input in controller.
<b>TOTAL ALARM</b>	
<b>Occurs if the flow meter or feed monitor totalizer alarm limit is exceeded.</b>	
Possible Cause	Corrective Action
Normal operation	Reset the total to clear alarm, or wait for the automatic total reset to occur.
AC coupled onto flow meter cable	Route cable at least 6 inches (150 mm) away from any AC voltage
Noise coupled onto flow meter cable	Shield cable
<b>RANGE ALARM (for flow meter or feed monitor type digital inputs)</b>	
<b>Occurs if the flow meter or feed monitor accumulated total is too large. The maximum total is 1 trillion times the increment of the device. For example, if the increment is one gallon per pulse the maximum total is 1 trillion gallons.</b>	
Possible Cause	Corrective Action
Normal operation	Reset the total to clear alarm, or wait for the automatic total reset to occur.
<b>FLOW VERIFY</b>	
<b>Occurs if the feed monitor digital input does not register any contacts while the control output for that pump has been active for longer than the Flow Alarm Delay time.</b>	
Possible Cause	Corrective Action
Metering pump has lost prime	Re-prime metering pump
Faulty metering pump	Repair or replace metering pump
<b>Incorrect feed monitoring device wiring</b>	Correct wiring. Make sure that digital input that the feed monitoring device is connected to has been assigned to the correct relay
<b>Faulty feed monitoring sensor</b>	Replace feed monitoring sensor
<b>Blown fuse</b>	Verify the pump is getting power. Replace fuse
<b>Faulty output relay</b>	Replace relay board

<b>Faulty digital input</b>	Verify that feed monitoring device is making contact closures using an ohmmeter. If OK, and connected properly, replace the controller circuit board.
<b>OUTPUT TIMEOUT</b> This error condition will stop control. It is caused by the output (either relay or analog) being activated for longer than the programmed Time Limit.	
<b>Possible Cause</b>	<b>Corrective Action</b>
The process went further out of control than normal.	Increase time limit or reset timer.
The chemical supply has run out.	Replenish the chemical supply.
The pump or valve or supply line is faulty.	Repair or replace the control device.
Wrong chemical is being controlled.	Replace with correct chemical.
The sensor is not responding to changes.	Replace sensor. Evaluate mixing or recirculation.
<b>RANGE ALARM (for sensor inputs)</b> It indicates that the signal from the sensor is out of the normal range. This error condition will stop control of any output using the sensor. This prevents controlling based upon a false sensor reading. If the temperature sensor goes into range alarm, then the controller will go into manual temperature compensation using the Default Temperature setting.	
<b>Possible Cause</b>	<b>Corrective Action</b>
Sensor wires shorted	Disconnect short
Faulty sensor	Replace sensor
Faulty controller	Replace or repair controller
<b>EVENT SKIPPED ALARM</b> An event skipped alarm is set when a second biocide or timer event occurs while one event is still running (either in prebleed, biocide-add or post-biocide add lockout in the case of the biocide timer mode). An event skipped alarm is also set when the timer relay never turns on during an event because of an interlock condition. The alarm is cleared when the relay is next activated for any reason (the next timer event or HAND mode or “activate with” force on condition).	
<b>Possible Cause</b>	<b>Corrective Action</b>
Incorrect programming	Reprogram to eliminate overlapping events
Long duration interlock condition	Normal operation
Long duration prebleed	Decrease prebleed time Increase bleed flow rate Reprogram to eliminate overlapping events
<b>SENSOR FAULT</b> This error indicates that the signal from the sensor is no longer valid at all. This error condition will stop control of any output using the sensor.	
<b>Possible Cause</b>	<b>Correction Action</b>
Sensor wires shorted	Disconnect short
Faulty sensor	Replace sensor
Faulty controller	Replace or repair controller
<b>INPUT FAILURE</b> This alarm indicates that the sensor input circuit is no longer working, or that one of the inputs used to calculate a virtual input is in a Sensor Fault condition. This error condition will stop control of any output using the input.	
<b>Possible Cause</b>	<b>Correction Action</b>
Faulty controller	Replace or repair controller
If using virtual inputs, sensor fault of one of the inputs	See Sensor Fault troubleshooting above
<b>BATTERY POWER LOW</b> This alarm indicates that the battery which holds the date and time in memory is below 2.4 VDC.	
<b>Possible Cause</b>	<b>Correction Action</b>
Faulty battery	Replace battery
<b>SYSTEM TEMP LOW</b> This alarm indicates that the temperature inside the controller is below -10 °C.	
<b>Possible Cause</b>	<b>Correction Action</b>
Low ambient temperatures	Provide heat for the controller

<b>SYSTEM TEMP HIGH</b>	
<b>This alarm indicates that the temperature of the controller or sensor processor IC is above 75 °C, or that the temperature of the Ethernet card processor IC is above 85 °C.</b>	
<b>Possible Cause</b>	<b>Correction Action</b>
High ambient temperatures	Provide cooling for the controller
High power draw	Do not use the controller's 24VDC to power more than 1.5W total
<b>DISPLAY ERROR</b>	
<b>This alarm occurs if the user interface gets lost</b>	
<b>Possible Cause</b>	<b>Correction Action</b>
Pressing icons very quickly	Exit out of the screen and continue programming
<b>ETHERNET CARD FAILURE</b>	
<b>This alarm occurs if the Ethernet circuit board fails</b>	
<b>Possible Cause</b>	<b>Correction Action</b>
Ethernet card locked up	Try a power cycle to reset it
Faulty Ethernet circuit	Replace Controller Board
<b>WEB SERVER FAILURE</b>	
<b>This alarm occurs if the web server on the Ethernet circuit board fails</b>	
<b>Possible Cause</b>	<b>Correction Action</b>
Web server locked up	Try a power cycle to reset it
Faulty Ethernet card	Replace Ethernet card
<b>Fluent DATA COMM ERROR</b>	
<b>This alarm occurs if the controller attempts to send data to Fluent and Fluent fails to acknowledge receipt of the data</b>	
<b>Possible Cause</b>	<b>Correction Action</b>
No connection to LAN	Connect Ethernet cable to LAN
Wrong IP, subnet and/or gateway address	Program valid settings for LAN in the controller or use DHCP if supported by the LAN
LAN is blocking outside access	Program LAN's router to open access
Network card failure	See above
<b>SENSOR CAL REQUIRED</b>	
<b>This alarm occurs if the sensor's Cal Reminder Alarm has been set to more than 0 days and if the sensor has not been calibrated within that number of days</b>	
<b>Possible Cause</b>	<b>Correction Action</b>
Time to calibrate	Calibrate the sensor
Reminder set in error	Set the Cal Reminder Alarm to 0
<b>CALCULATION ERROR</b>	
<b>This alarm occurs if a virtual input calculation cannot be completed, for example if it has to divide by zero.</b>	
<b>Possible Cause</b>	<b>Correction Action</b>
Zero value for the input used as the denominator	Calibrate or evaluate that input
<b>FLOW VERIFY</b>	
Occurs if the feed monitor digital input does not register any contacts while the control output for that pump has been active for longer than the Flow Alarm Delay time.	
<b>Possible Cause</b>	<b>Correction Action</b>
Metering pump has lost prime	Re-prime metering pump
Faulty metering pump	Repair or replace pump
Faulty verification device wiring	Correct wiring
Wrong digital input assigned to the output	Correct programming error
Faulty verification device	Repair or replace device
Faulty wiring of output to pump	Correct wiring
Faulty output board	Repair or replace board
Faulty digital input	Replace board

<b>CONTROLLER, POWER, DISPLAY, OR SENSOR BOARD ERROR</b>	
<b>This alarm occurs if the board listed is not recognized</b>	
<b>Possible Cause</b>	<b>Correction Action</b>
Poor ribbon cable connection	Remove and reseal ribbon cable, cycle power
Poor option card connection	Remove and reseal the board, cycle power
Faulty board	Return the controller for repair
<b>CONTROLLER, POWER, SENSOR, DISPLAY, NETWORK OR ANALOG OUTPUT BOARD VARIANT</b>	
<b>This alarm occurs if the type of board that is detected is not a valid type</b>	
<b>Possible Cause</b>	<b>Correction Action</b>
Poor ribbon cable connection	Reseat ribbon cable
Faulty ribbon cable	Replace ribbon cable
Faulty Board	Replace the board listed in the error message
<b>SENSOR SOFTWARE VERSION</b>	
<b>This alarm occurs if a sensor input card with software v2.11 or lower is installed onto a controller board running software v2.13 or higher</b>	
<b>Possible Cause</b>	<b>Correction Action</b>
Software is not compatible between boards	Perform a Software Upgrade
<b>INVALID SENSOR TYPE</b>	
<b>This alarm occurs if the programmed sensor type is not possible for the installed sensor board</b>	
<b>Possible Cause</b>	<b>Correction Action</b>
The sensor board has been removed and replaced with a different type	Reinstall the correct board or reprogram the input to a valid type for the board installed
<b>INVALID CONTROL MODE</b>	
<b>This alarm occurs if the programmed control mode is not possible for the installed power relay board</b>	
<b>Possible Cause</b>	<b>Correction Action</b>
The power relay board has been removed and replaced with an incorrect model	Reinstall the correct board or reprogram the output to a valid type for the board installed
<b>Fluent LIVE CONNECT ERROR</b>	
<b>This alarm occurs if the controller is unable to establish an encrypted connection to the Fluent server. If there is also a Fluent Data Comm Error, fix that first.</b>	
<b>Possible Cause</b>	<b>Correction Action</b>
No UDP support on Port 9012 or TCP support on Port 44965	Open ports/protocols on router
<b>DISABLED (SENSOR, DIGITAL OR VIRTUAL INPUT; RELAY OR ANALOG OUTPUT)</b>	
<b>This alarm occurs if software for that input or output did not start correctly</b>	
<b>Possible Cause</b>	<b>Correction Action</b>
The software is not functioning	If the error message clears on its own, no action is required. If the error message persists, cycle power. If the error message still persists, return the controller for repair.
<b>RELAY OR ANALOG OUTPUT CONTROL FAILURE</b>	
<b>This alarm occurs if software for that output did not run correctly</b>	
<b>Possible Cause</b>	<b>Correction Action</b>
The software is not functioning	If the error message clears on its own, no action is required. If the error message persists, cycle power. If the error message still persists, return the controller for repair.
<b>FRAM FILE SYSTEM ERROR</b>	
<b>This alarm occurs if the FRAM is not detected at power up</b>	
<b>Possible Cause</b>	<b>Correction Action</b>
The FRAM was or is not functioning	If the error message clears on its own, no action is required. If the error message persists, cycle power. If the error message still persists, replace the controller board.
<b>REPLACE ELECTRODES</b>	
<b>Occurs if the user has set an Electrode Alarm and the number of days selected since the last time “Replace Corrosion Electrode” has been confirmed has passed.</b>	
<b>Possible Cause</b>	<b>Corrective Action</b>

The Electrode Alarm timer has expired	Replace the electrodes and then confirm in the Replace Corrosion Electrode menu
<b>WiFi MODULE FAILURE</b>	
<b>The WiFi module is not responding</b>	
<b>Possible Cause</b>	<b>Corrective Action</b>
WiFi board not connected properly	Power down, reseal WiFi board, power up
Faulty WiFi board	Replace WiFi board
<b>WiFi CONNECTION ERROR</b>	
The WiFi module is unable to connect to the specified Infrastructure access point	
<b>Possible Cause</b>	<b>Corrective Action</b>
Missing settings	WiFi Status will be “Invalid Config”. Enter the missing settings.
Incorrect settings	Check with the LAN admin for the correct settings
Invalid key	WiFi Status will be “Invalid Key”. Check with the LAN admin for the correct settings.
Poor signal	WiFi status will be “Network Not Found” or “Unable to Connect”. Improve signal.
Access point is not working	WiFi status will be “Network Not Found” or “Unable to Connect”. Have LAN admin check access point functionality.
Faulty WiFi board	Replace WiFi board
<b>UPDATE TIMEOUT</b>	
This alarm occurs if a Remote Modbus Input does not receive the requested data within the programmed Timeout Alarm Delay time	
<b>Possible Cause</b>	<b>Corrective action</b>
No Ethernet connection to the Modbus application	Check wiring
Invalid Modbus communications settings	Check settings
Timeout Alarm Delay time is too short	Increase delay time
<b>MESSAGE ERROR</b>	
This alarm occurs if the Remote Modbus Input receives an error message from the Modbus application instead of the requested data	
<b>Possible Cause</b>	<b>Corrective action</b>
Invalid Modbus communications settings	Check settings. Enable Verbose Logging to see the exact error.
<b>BOOLEAN ALARM</b>	
This alarm occurs if a Boolean Logic output is in the state in which it is programmed to alarm.	
<b>Possible Cause</b>	<b>Corrective action</b>
Improperly programmed	Program correctly
Normal operation	Respond to the cause of the relay being in the alarm state
<b>DAILY MAX TIMEOUT</b>	
This alarm occurs if an output has been activated for longer than the programmed Daily Max Time Limit.	
<b>Possible Cause</b>	<b>Corrective Action</b>
Improperly programmed	Program correctly
Normal operation	Respond to the cause of the relay being activated for too long

### 8.3 Procedure for Evaluation of Conductivity Electrode

Try cleaning the electrode first (refer to Sect. 7.1). To check the electrode, check the electrode connections to the terminal strip (refer to Figure 7). Make sure that the correct colors go to the correct terminals, and that the connections are tight. Restore power and see if the conductivity is back to normal. If not, replace the electrode.

### 8.4 Procedure for Evaluation of the pH/ORP Electrode

The most common cause of a calibration failure is an electrode problem. First try cleaning the electrode, then retry the calibration. If this fails again, replace the electrode and retry the calibration.

The next most common problem is wet or poor connections. Check the connection of the electrode to the cable for moisture. Check the connections between the cable and the terminal strip. Make sure that they are tight, that the

terminal is not clamped to the plastic jacket, and that the wires are routed to the correct terminal. If there is a junction box installed between the electrode and the controller, check the wiring there as well.

You should be able to measure the +5VDC  $\pm 5\%$  and -5VDC  $\pm 5\%$  vs IN- at the terminal strip. If not, the controller is faulty. You should be able to measure the IN+ vs IN- (DC scale) and get the appropriate values for the buffer solutions used. If not, the preamplifier or its wiring is faulty.

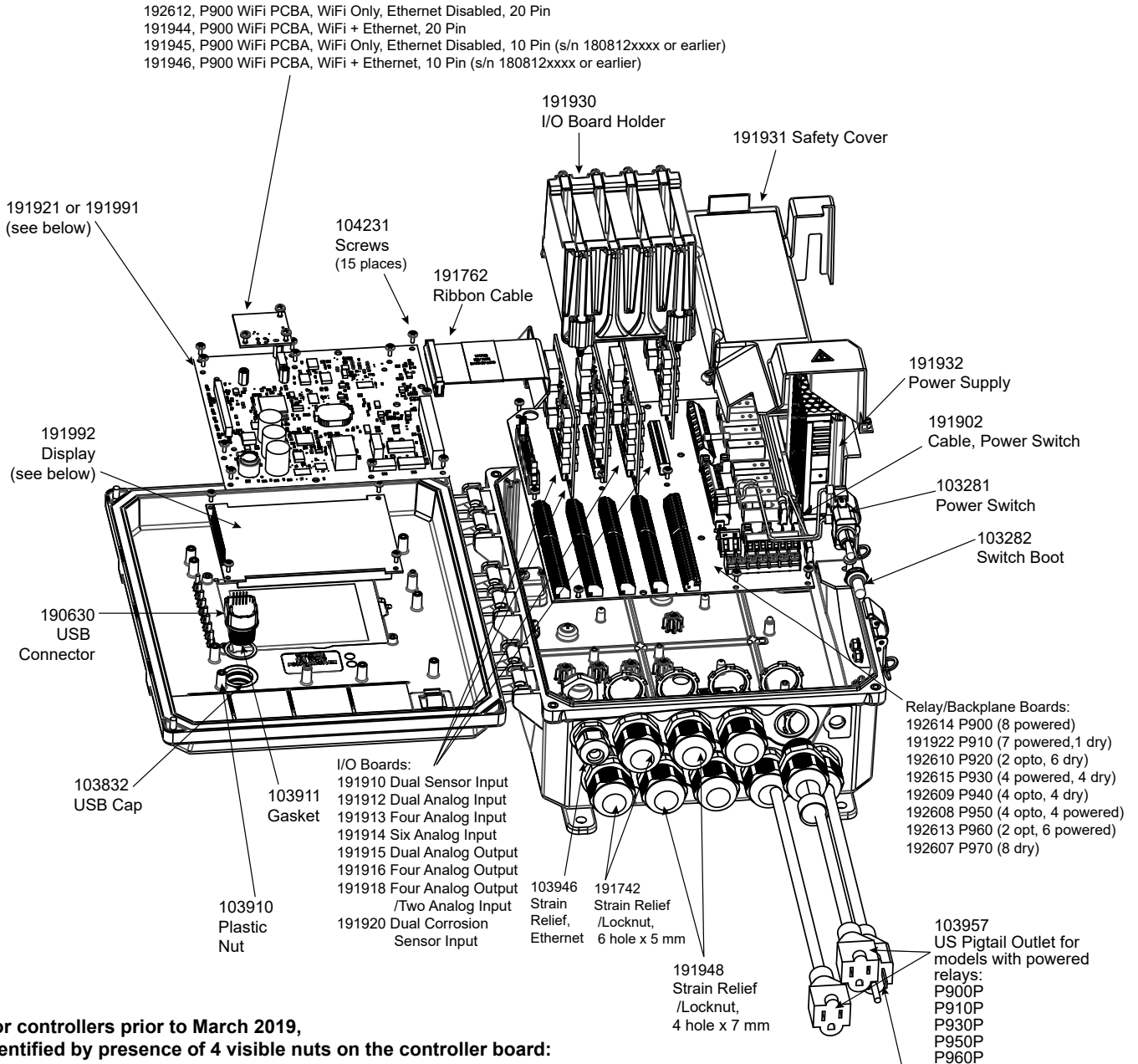
The last possibility is to try replacing the preamplifier.

## 8.5 Diagnostic Lights

Some of the circuit boards inside the controller have diagnostic lights.

<b>CONTROLLER BOARD D12 LED</b>	
<b>Indicates status of the software application. Normal operation is that 5 seconds after power-up, it does one long blink on, two short blinks, on long blink off. If it is not doing this:</b>	
Possible Cause	Correction Action
Controller software is not running	Try a power cycle to reset it
Faulty controller board	Replace controller board
<b>CONTROLLER BOARD D14 LED</b>	
<b>Indicates the status of the Ethernet software. Normal operation is that 5 seconds after power-up, it does 5 seconds on, 5 seconds off. If it is not doing this:</b>	
Possible Cause	Correction Action
Ethernet software is not running	Try a power cycle to reset it
Faulty controller board	Replace controller board
<b>CONTROLLER BOARD D15 LED</b>	
<b>Indicates the status of the digital input software. Blinks slowly for a few seconds during power-up. Normal operation is OFF. If not behaving this way:</b>	
Possible Cause	Correction Action
Digital input software locked up	Try a power cycle to reset it
Faulty controller board	Replace controller board
<b>CONTROLLER BOARD D13 LED</b>	
<b>Indicates the status of the 12VDC power supply. Normal operation is ON. If not on:</b>	
Possible Cause	Correction Action
Faulty ribbon cable	Replace ribbon cable
Faulty power supply	Replace power supply
<b>CONTROLLER BOARD D11 LED</b>	
<b>Indicates the status of the 5VDC power supply. Normal operation is ON. If not on:</b>	
Possible Cause	Correction Action
Faulty ribbon cable	Replace ribbon cable
Faulty power supply	Replace power supply
<b>CONTROLLER BOARD D10 LED</b>	
<b>Indicates the status of the 3.3VDC power supply. Normal operation is ON. If not on:</b>	
Possible Cause	Correction Action
Faulty ribbon cable	Replace ribbon cable
Faulty power supply	Replace power supply
<b>I/O BOARD LEDs</b>	
<b>Indicates the status of the sensor board. Blinks slowly for several seconds during power-up. Normal operation is OFF. If not behaving this way:</b>	
Possible Cause	Corrective Action
Sensor card locked up	Try a power cycle to reset it
Sensor card not seated correctly	Unplug the card and plug it back in
Ribbon cable not seated correctly	Unplug the ribbon cable at each end and plug it back in
Faulty ribbon cable	Replace ribbon cable
Faulty sensor card	Replace sensor card

# 9.0 Spare Parts Identification



**For controllers prior to March 2019, identified by presence of 4 visible nuts on the controller board:**

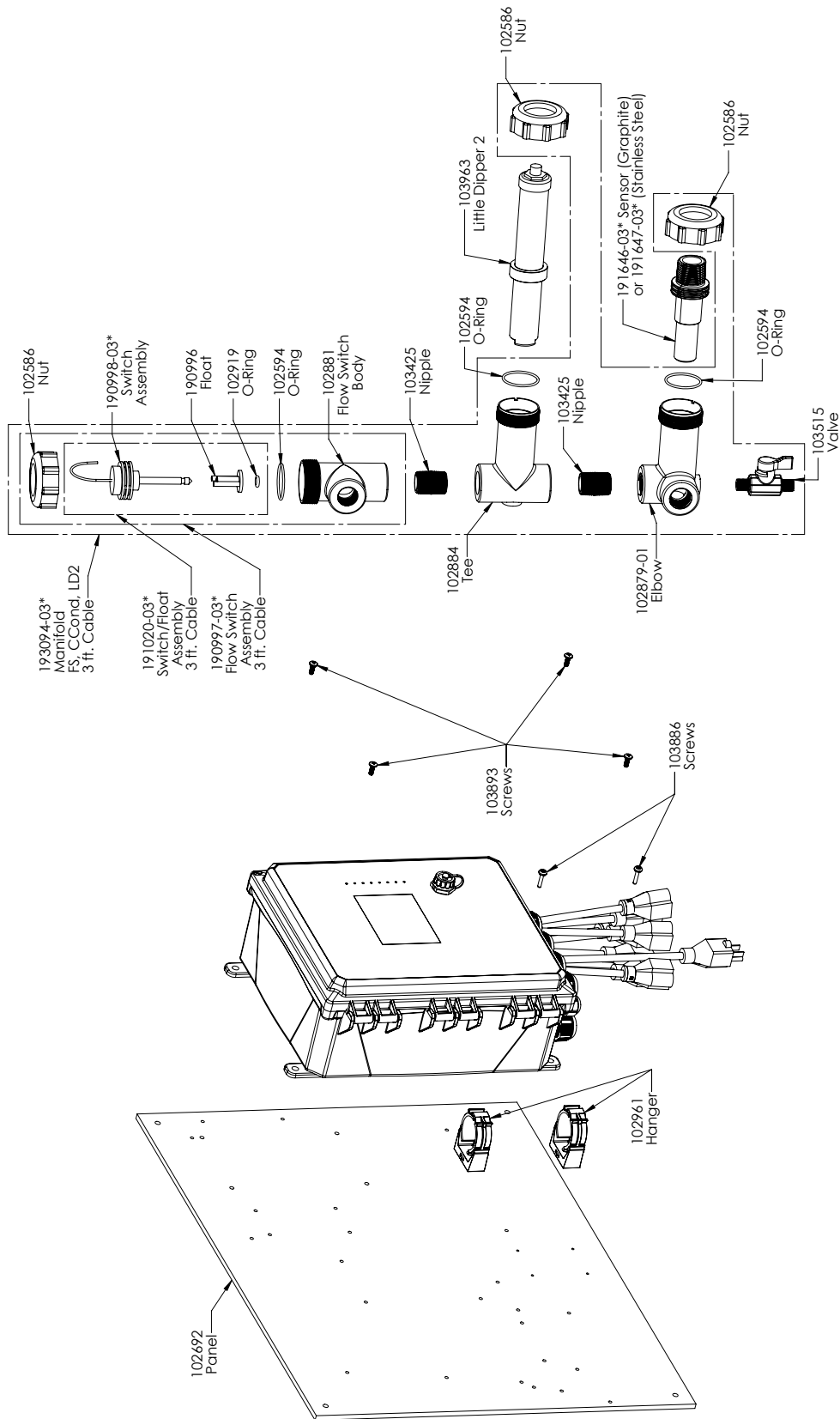
Order 191921 Controller Board + Display. If also using WiFi, order a new 20-pin WiFi card.  
 191921-SO-CT-N Cooling tower  
 191921-SO-BL-N Boiler  
 191921-SO-IN-N Industrial  
 Change -N to -M for Modbus or BACnet

**For controllers after March 2019, identified by absence of 4 visible nuts on the controller board:**

191992 Display may be ordered separately from the controller board.  
 Order 191991 Controller Board. If also using WiFi, that card may be re-used.  
 191991-SO-CT-N Cooling tower  
 191991-SO-BL-N Boiler  
 191991-SO-IN-N Industrial  
 Change -N to -M for Modbus or BACnet

103955 US Power Cord for P9x0P or  
 104147 DIN Power Cord for P9x0D or  
 104148 Brazil Power Cord for P9x0B

## Controller Parts



**SOCT900 Sensor Options PAFMNN, PBFMNN, PAHMNN, PBHMNN, PAIMNN, PBIMNN**

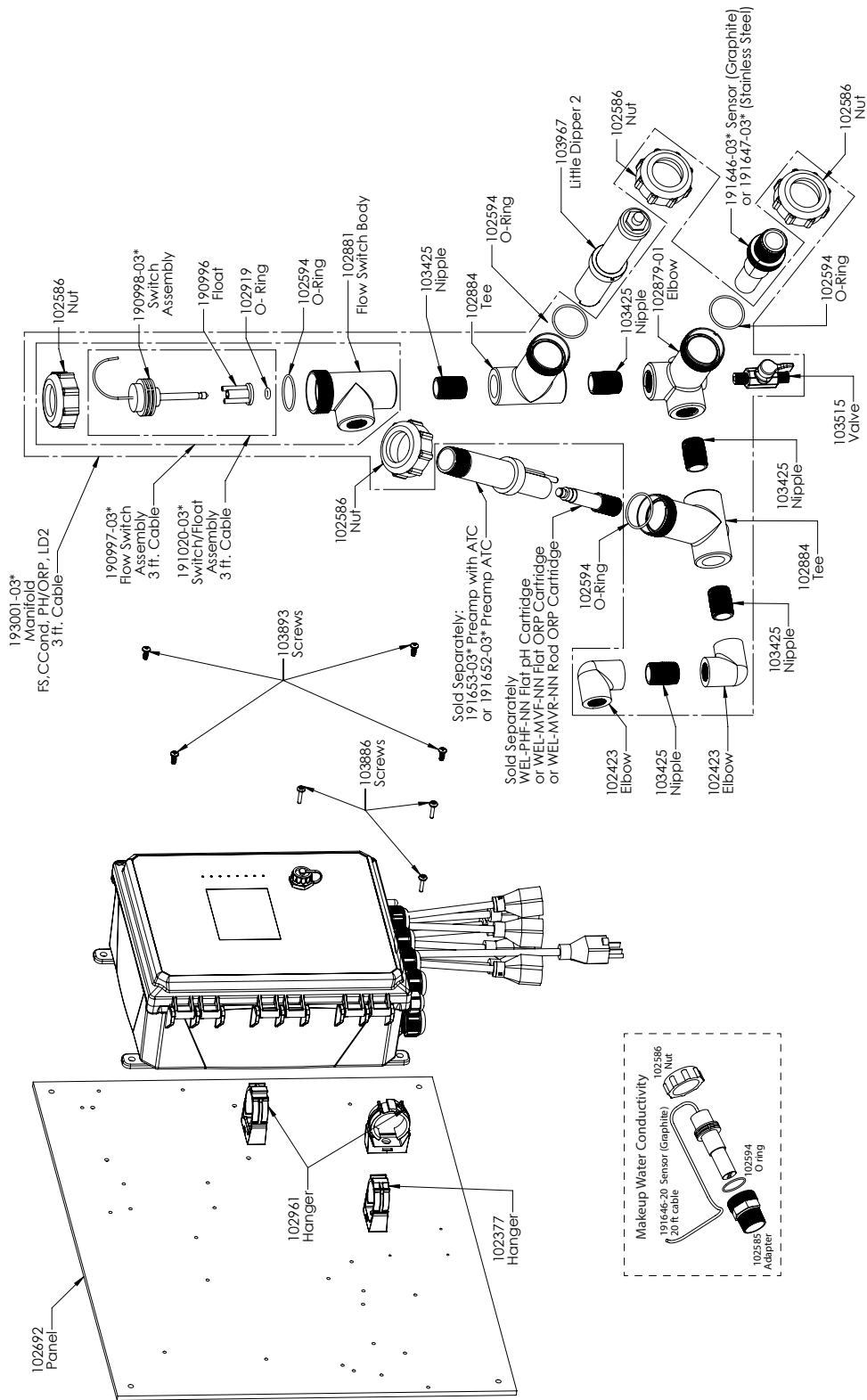
**PAFMNN:** Graphite contacting conductivity + Flow Switch manifold on panel + WEL-PHF no ATC + LD2

**PAHMNN:** + WEL-MVR + LD2      **PAIMNN:** + WEL-MVF + LD2

**PBFMNN:** 316SS contacting conductivity + Flow Switch manifold on panel + WEL-PHF no ATC + LD2

**PBHMNN:** + WEL-MVR + LD2      **PBIMNN:** + WEL-MVF + LD2





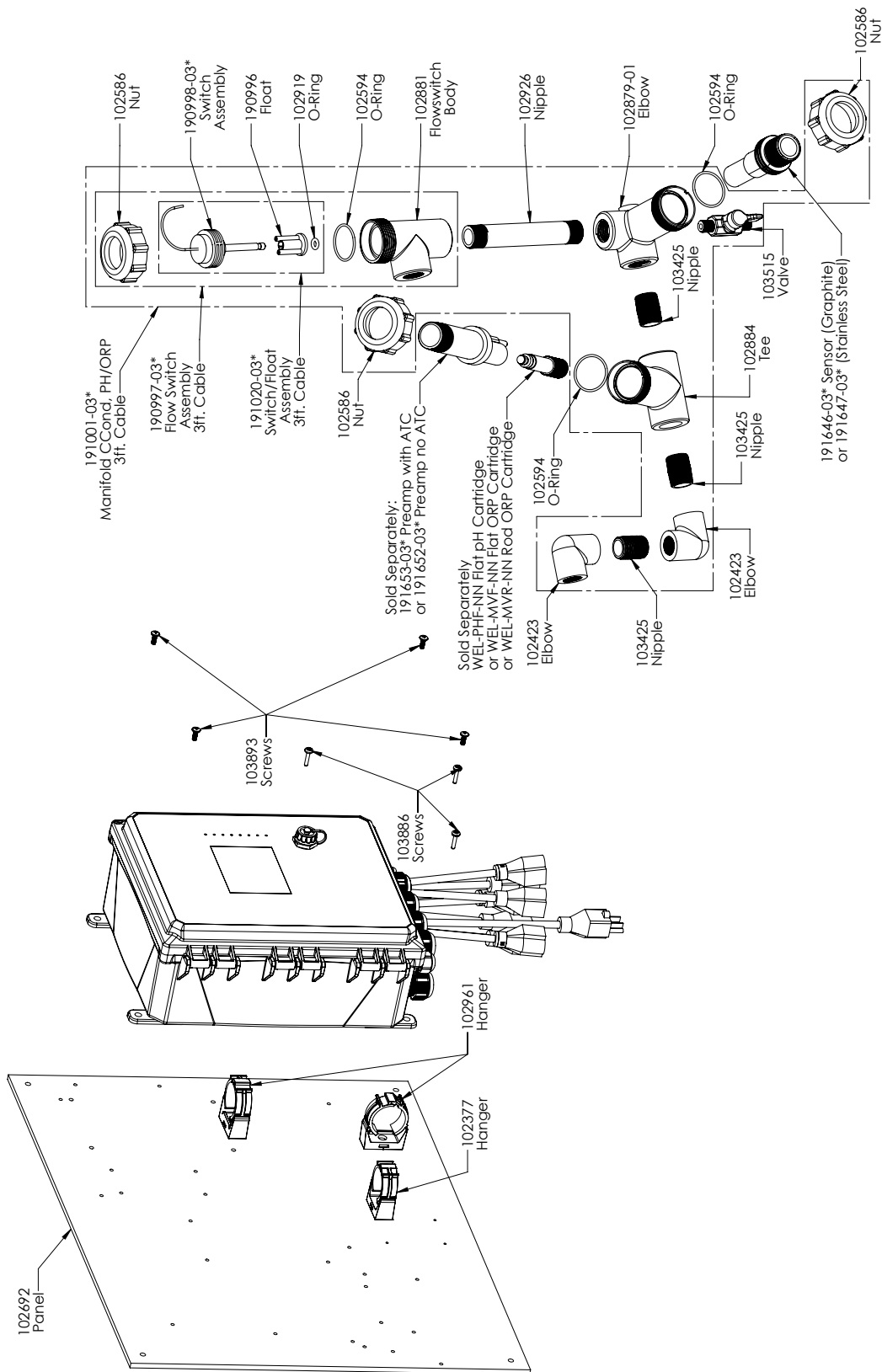
**SOCT900 Sensor Options PAEFMN, PBEFMN, PAEHMN, PBEHMN, PAEIMN, PBEIMN**

**PAEFMN:** Graphite contacting conductivity + Flow Switch manifold on panel  
 + Makeup Conductivity + WEL-PHF no ATC + LD2

**PAEHMN:** + WEL-MVR + LD2     **PAEIMN:** + WEL-MVF + LD2

**PBEFMN:** 316SS contacting conductivity + Flow Switch manifold on panel  
 + Makeup Conductivity + WEL-PHF no ATC + LD2

**PBEHMN:** + WEL-MVR + LD2     **PBEIMN:** + WEL-MVF + LD2



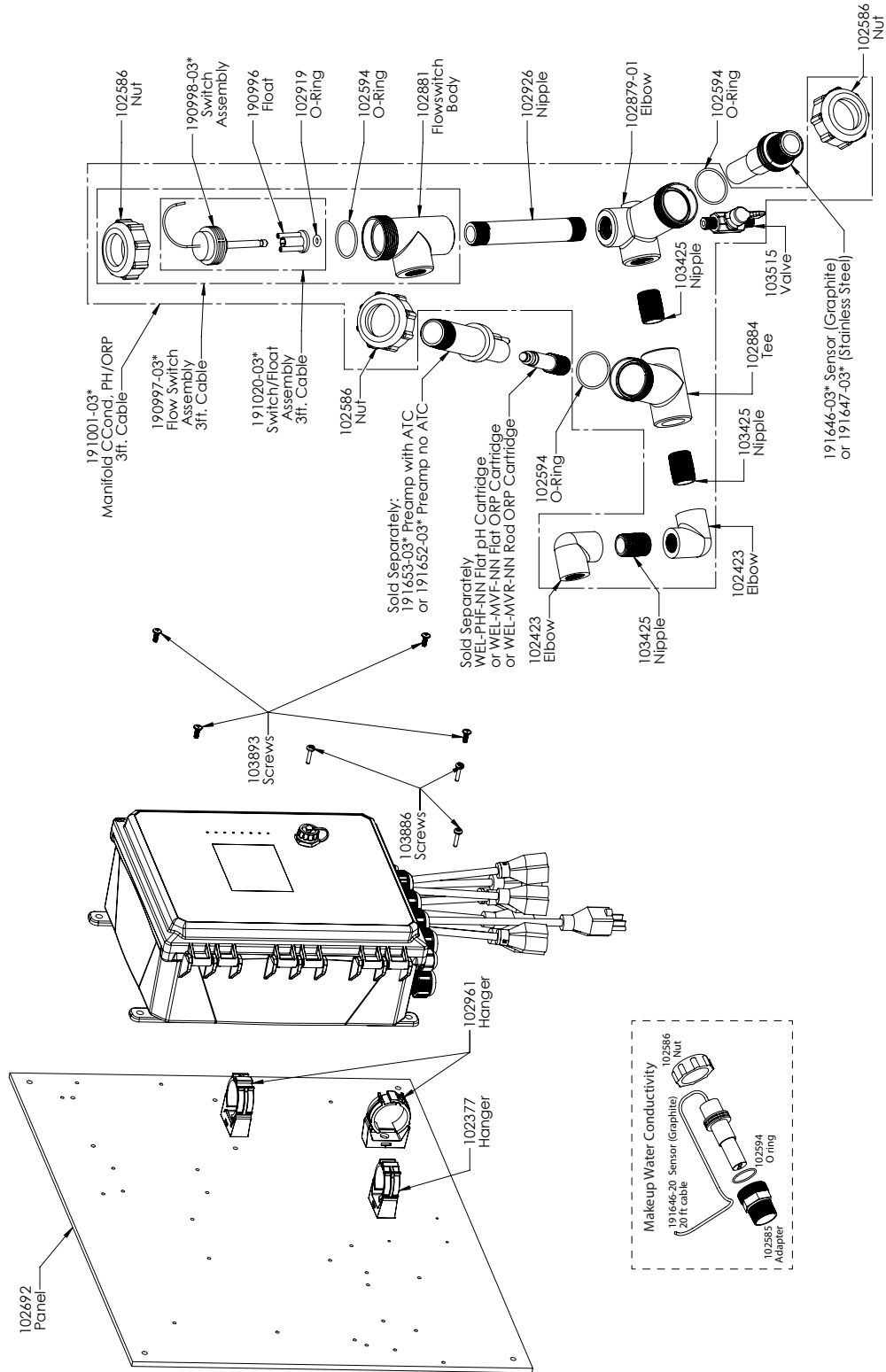
**SOCT90 Sensor Options PAFNNN, PBFNNN, PAHNNN, PBHNNN, PAINNN, PBINNN**

**PAFNNN:** Graphite contacting conductivity + Flow Switch manifold on panel + WEL-PHF no ATC

**PAHNNN:** + WEL-MVR      **PAINNN:** + WEL-MVF

**PBFNNN:** 316SS contacting conductivity + Flow Switch manifold on panel + WEL-PHF no ATC

**PBHNNN:** + WEL-MVR      **PBINNN:** + WEL-MVF



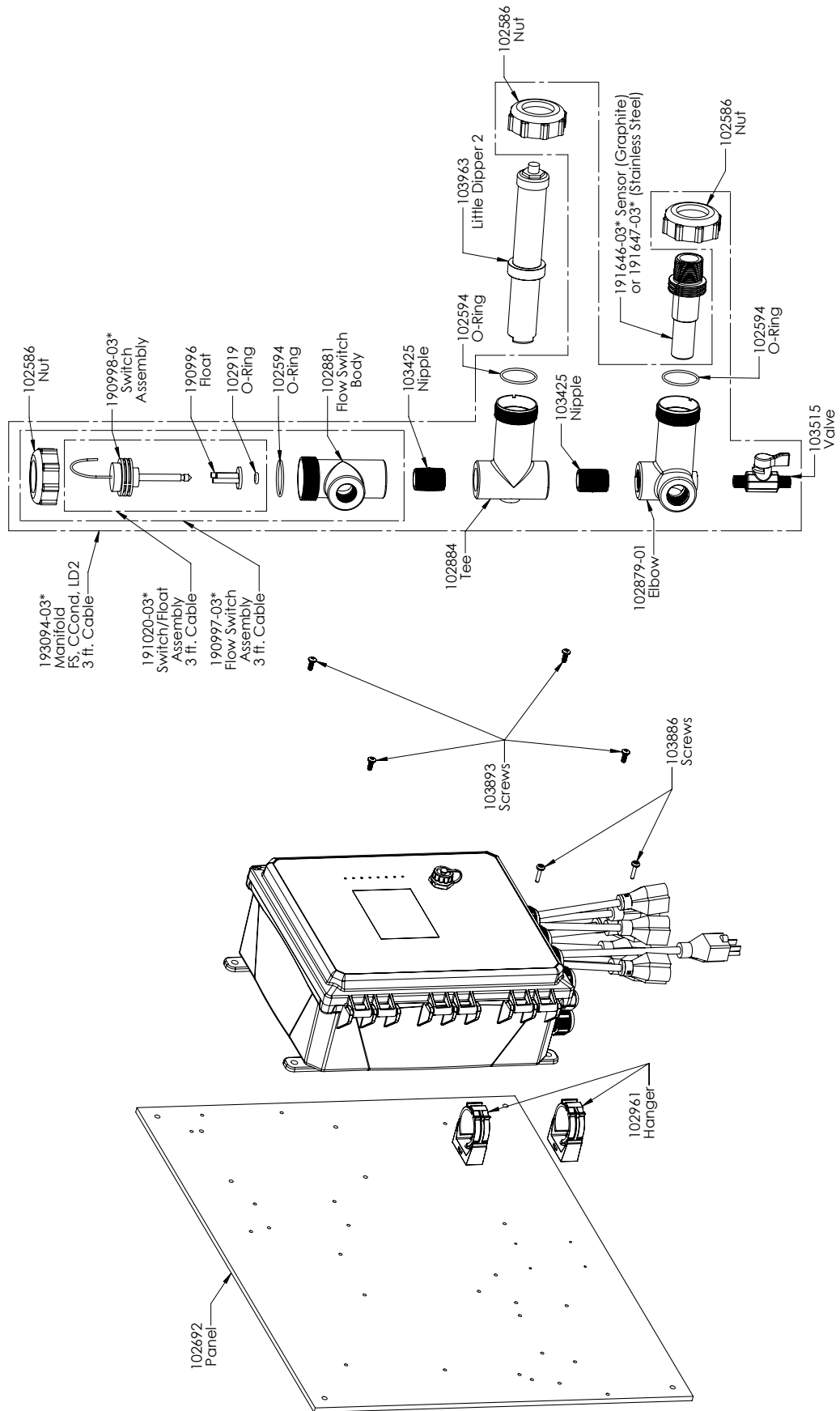
**SOCT90 Sensor Options PAEFNN, PBEFNN, PAEHNN, PBEHNN, PAEINN, PBEINN**

**PAEFNN:** Graphite contacting conductivity + Flow Switch manifold on panel  
+ Makeup Conductivity+ WEL-PHF no ATC

**PAEHNN:** + WEL-MVR      **PAEINN:** + WEL-MVF

**PBEFNN:** 316SS contacting conductivity + Flow Switch manifold on panel  
+ Makeup Conductivity + WEL-PHF no ATC

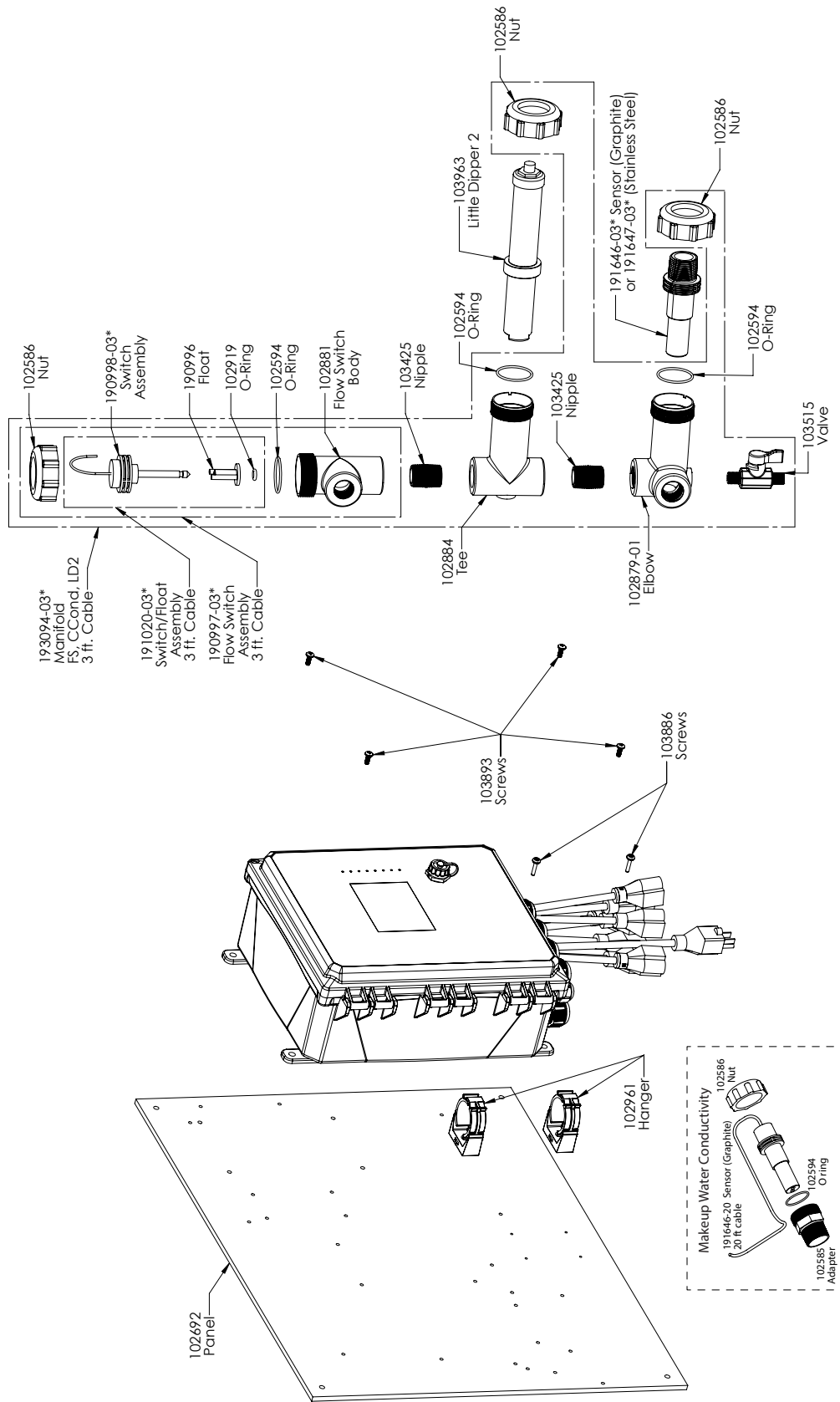
**PBEHNN:** + WEL-MVR      **PBEINN:** + WEL-MVF



### SOCT900 Sensor Options PAMNNN, PBMNNN

**PAMNNN:** Graphite contacting conductivity + Flow Switch manifold on panel + LD2

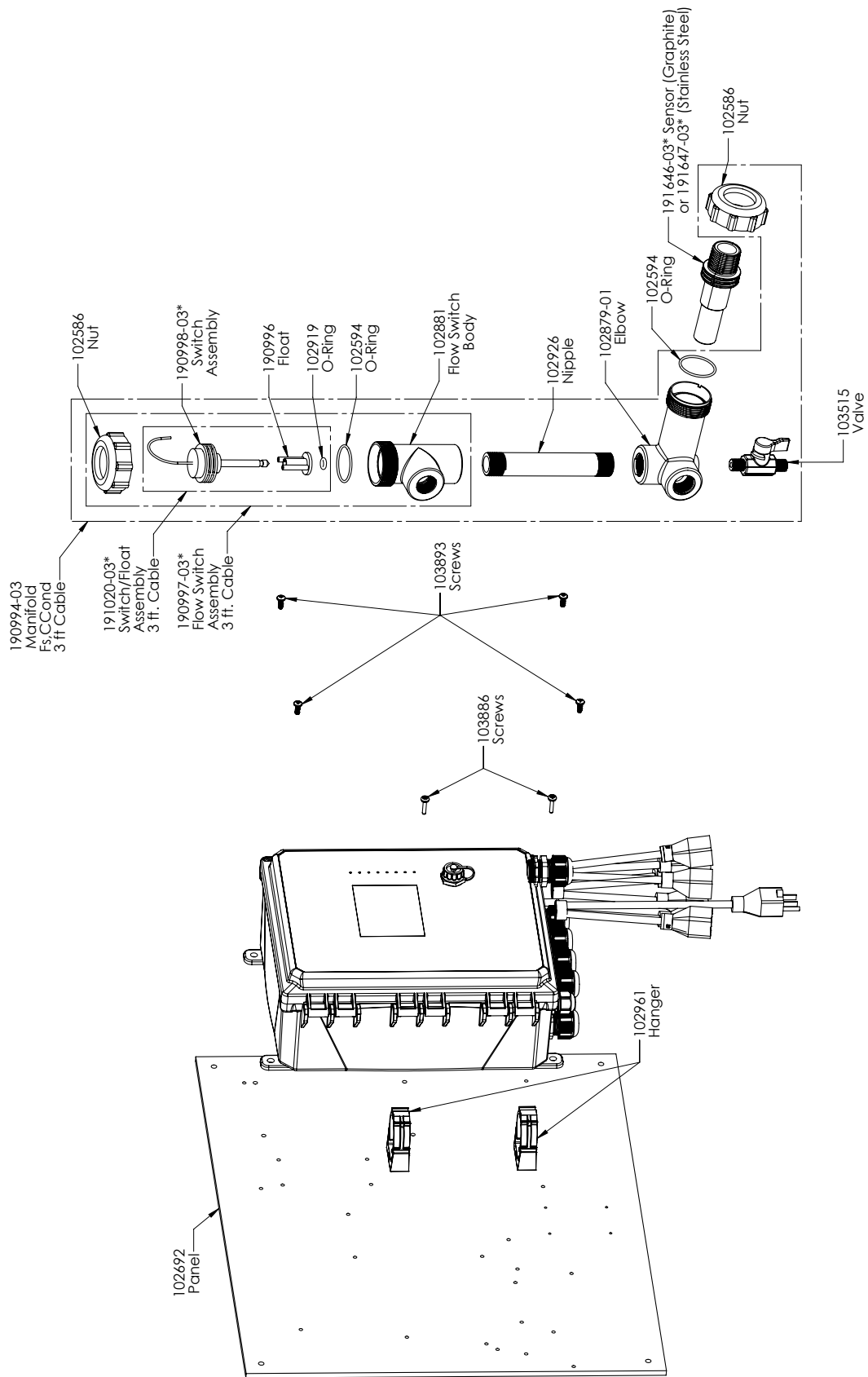
**PBMNNN:** 316SS contacting conductivity + Flow Switch manifold on panel + LD2



## SOCT90 Sensor Options PAEMNN, PBEMNN

**PAEMNN:** Graphite contacting conductivity + Flow Switch manifold on panel+ makeup sensor + LD2

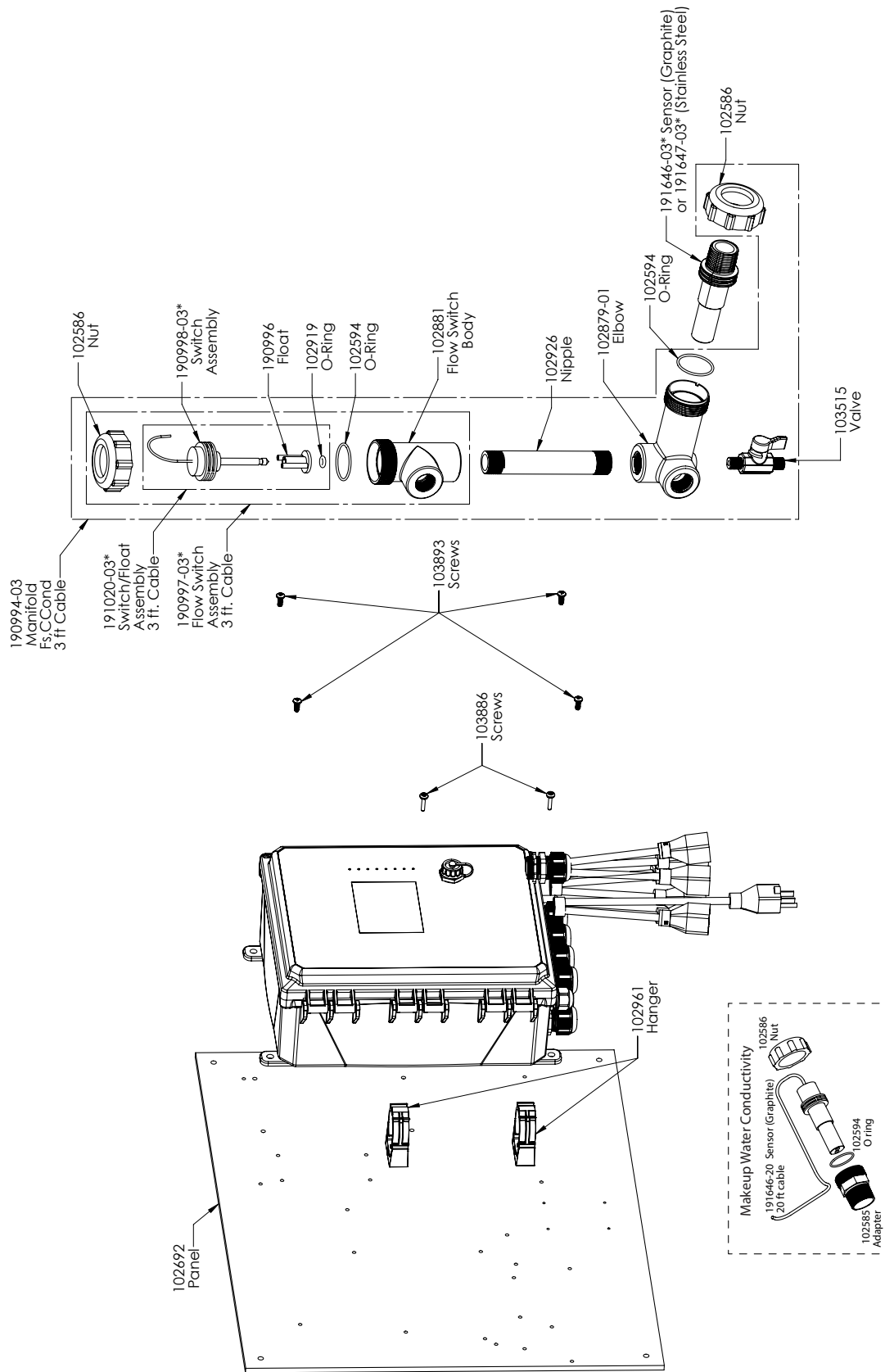
**PBMNNN:** 316SS contacting conductivity + Flow Switch manifold on panel + makeup sensor + LD2



### SOCT900 Sensor Options PANNNN, PBNNNN

**PANNNN:** Graphite contacting conductivity + Flow Switch manifold on panel

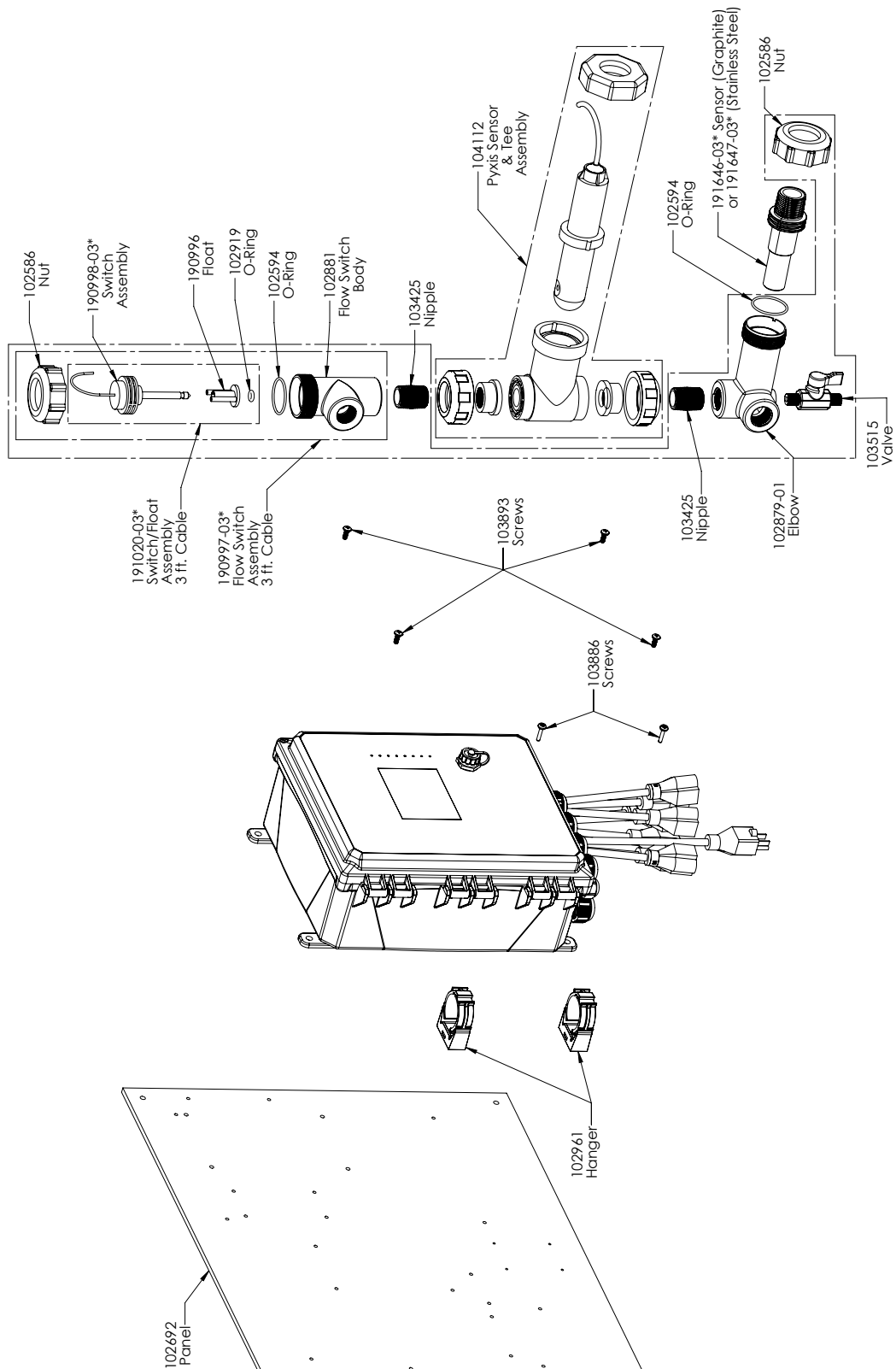
**PBNNNN:** 316SS contacting conductivity + Flow Switch manifold on panel



### SOCT900 Sensor Options PAENNN, PBENNN

**PAENNN:** Graphite contacting conductivity + Flow Switch manifold on panel + makeup sensor

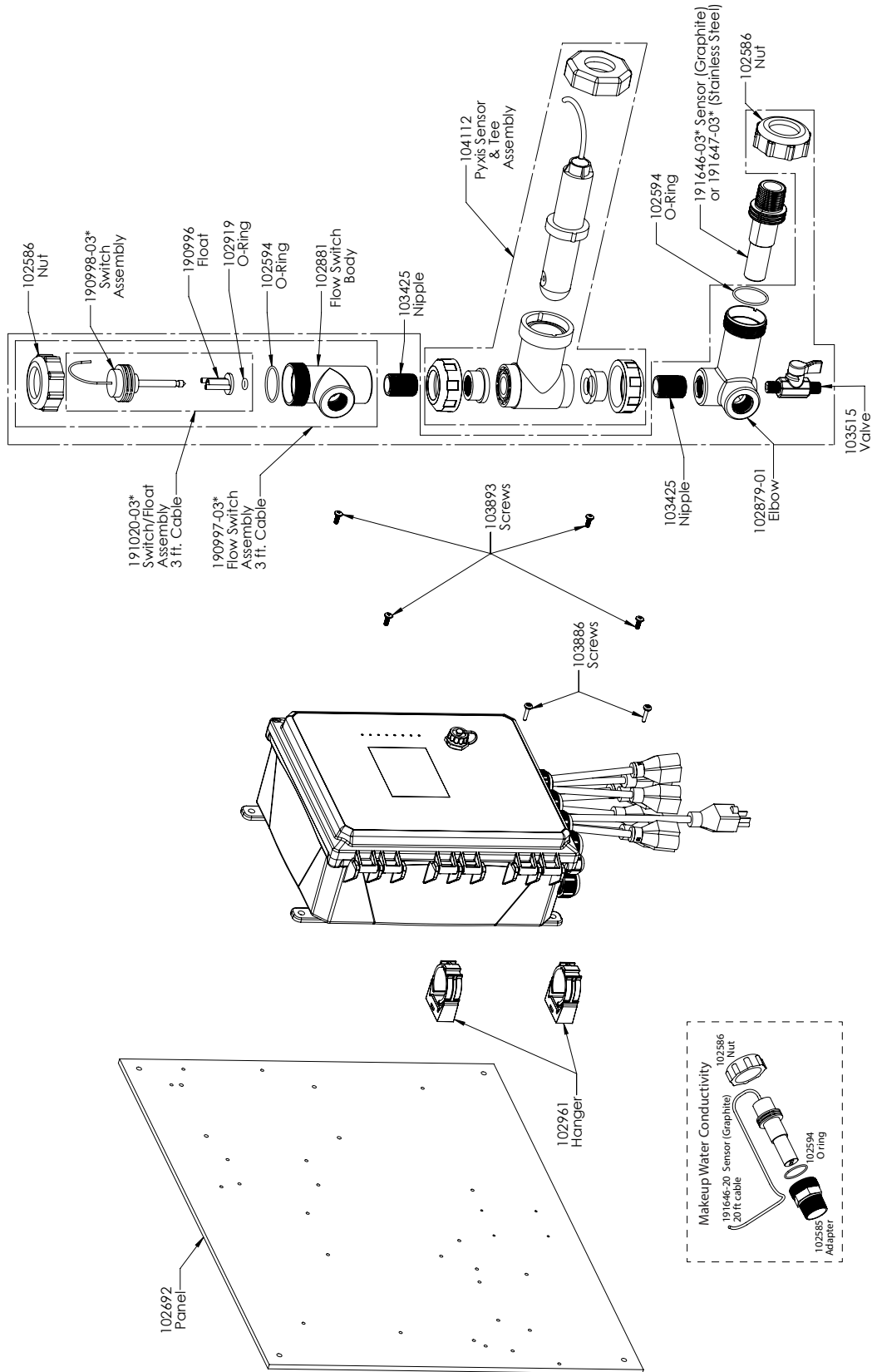
**PBENNN:** 316SS contacting conductivity + Flow Switch manifold on panel + makeup sensor



### SOCT90 Sensor Options PAPNNN, PBPNNN

**PAPNNN:** Graphite contacting conductivity + Flow Switch manifold on panel + Pyxis  
**PBPNNN:** 316SS contacting conductivity + Flow Switch manifold on panel + Pyxis

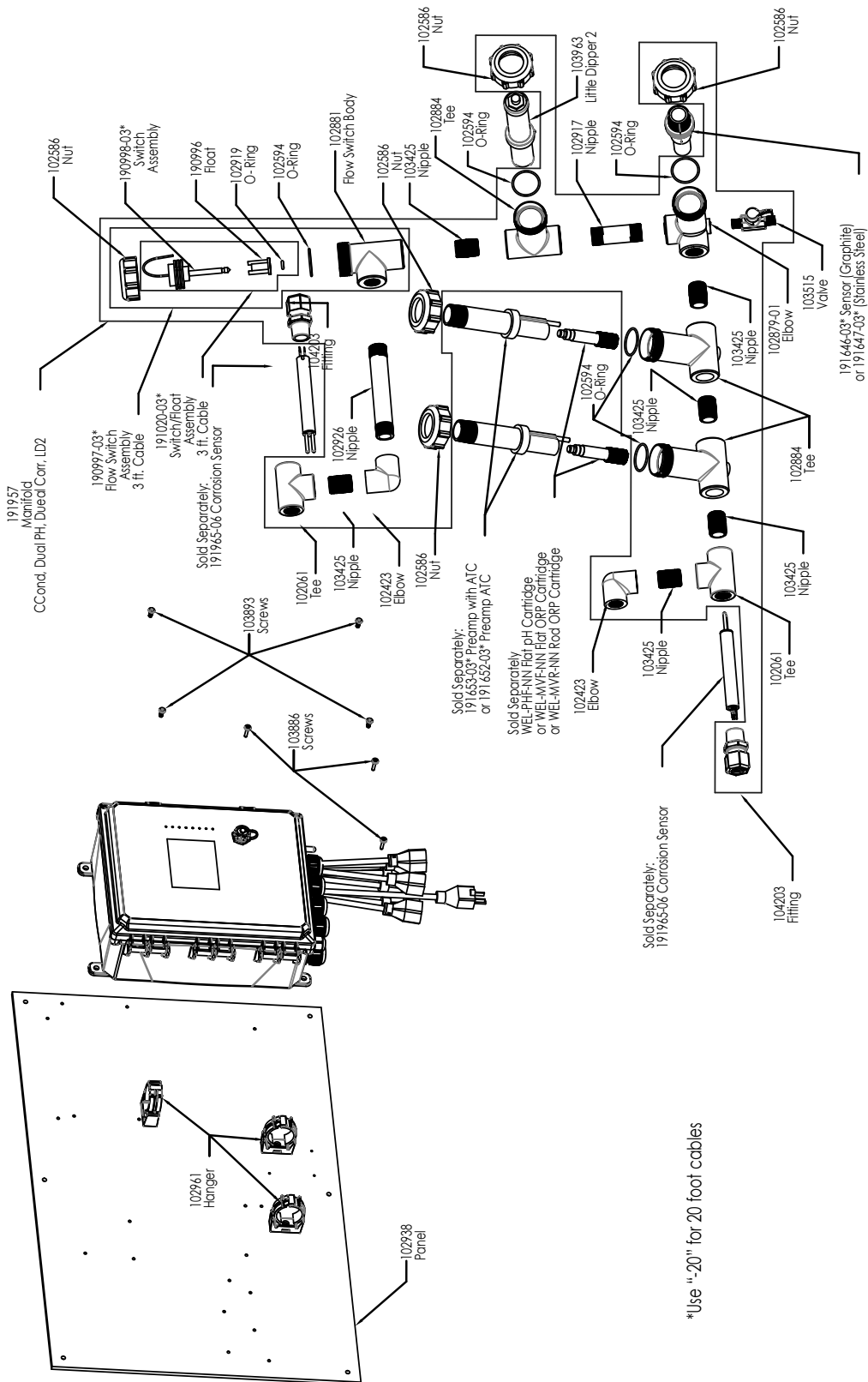




## SOCT900 Sensor Options PAEPNN, PBEPNN

**PAEPNN:** Graphite contacting conductivity + Flow Switch manifold on panel + Pyxis + makeup sensor

**PBEPNN:** 316SS contacting conductivity + Flow Switch manifold on panel + Pyxis + makeup sensor



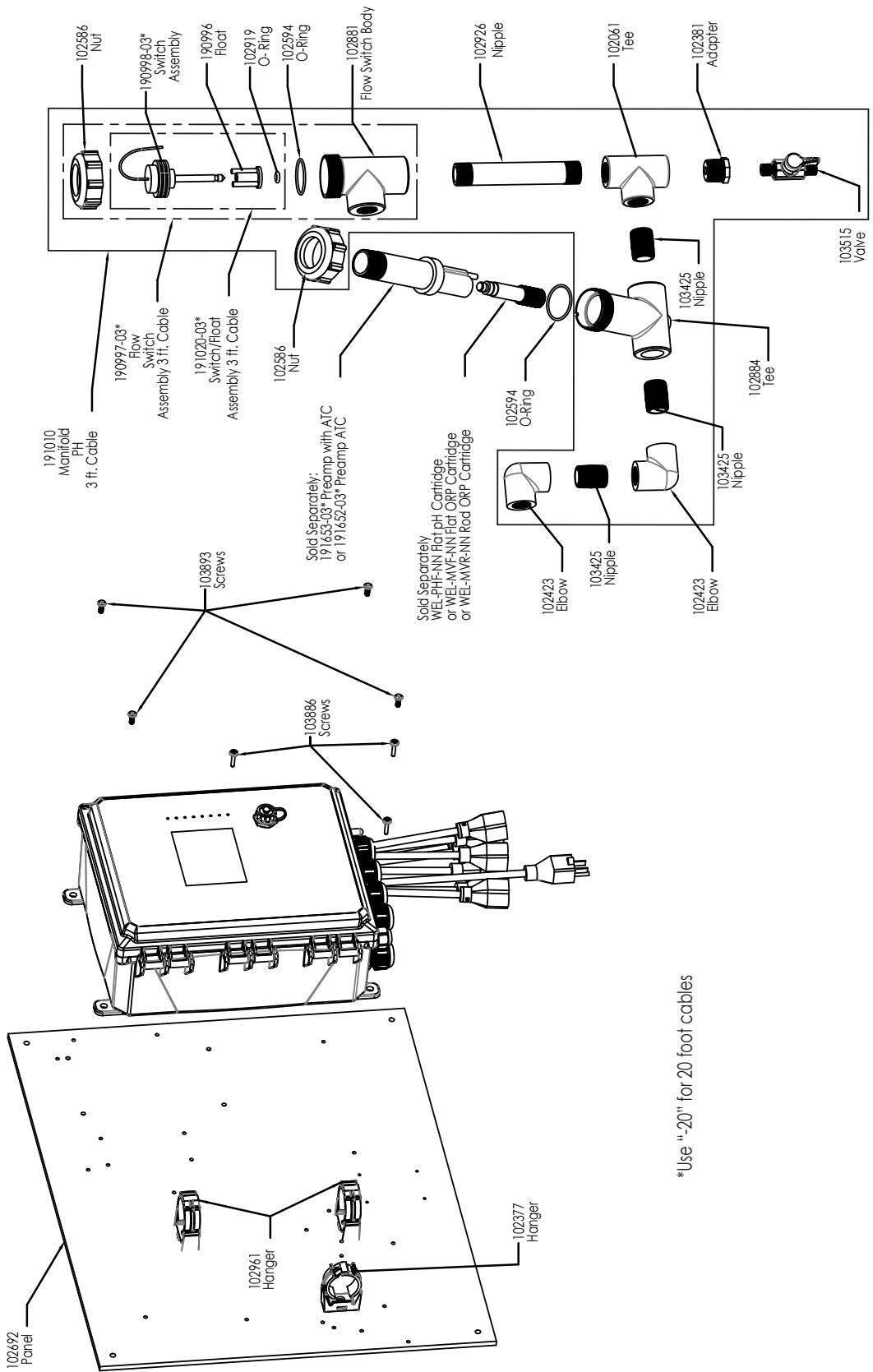
**SOCT90 Sensor Options PAFHMR, PBFHMR, PAFIMR, PBFIMR**

**PAFHMR:** Graphite contacting conductivity + Flow Switch manifold on panel + WEL-PHF no ATC + Little Dipper 2 +Dual Corrosion + WEL-MVR

**PAFIMR:** + WEL-MVF

**PBFHMR:** 316SS contacting conductivity + Flow Switch manifold on panel+ WEL-PHF no ATC + Little Dipper 2 + Dual Corrosion + WEL-MVR

**PBFIMR:** + WEL-MVF



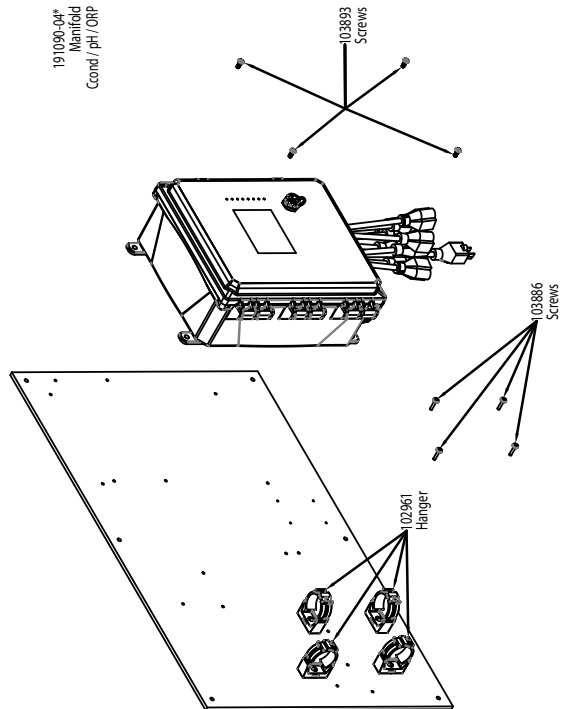
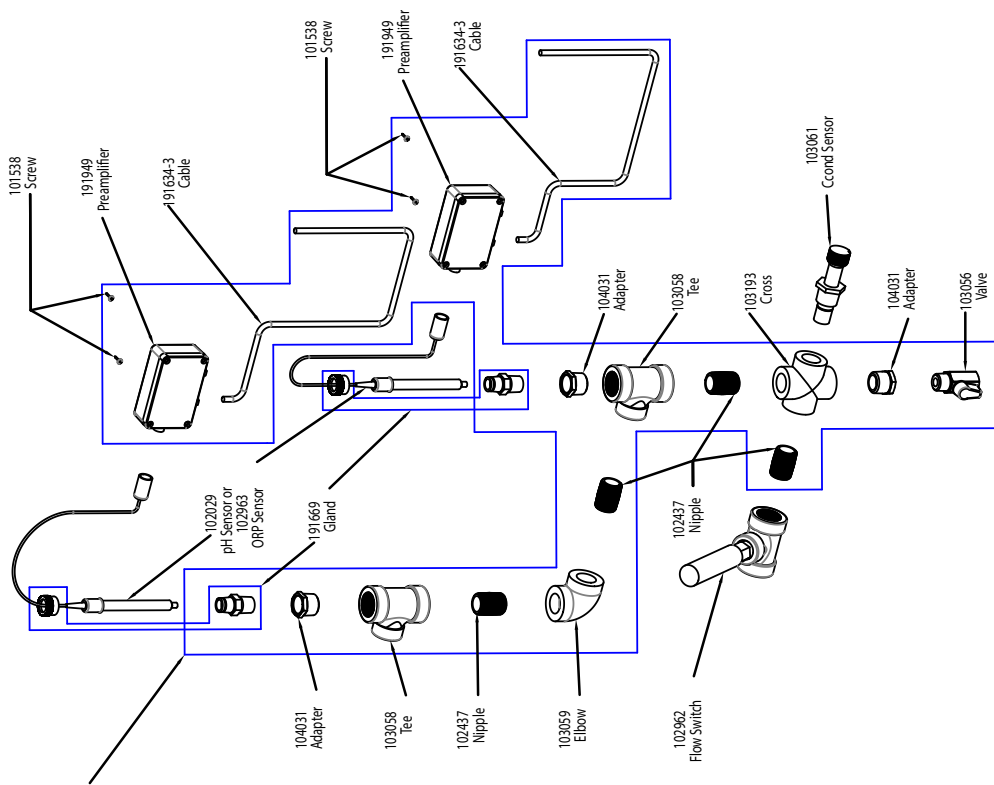
**SOCT900 Sensor Options PFNNNN, PHNNNN, PINNNN and WIN900 Sensor Option PBNNNN**

**SO900-CT-PFNNNN:** Flow Switch manifold on panel + WEL-PHF no ATC

**PHNNNN:** + WEL-MVR

**PINNNN:** + WEL-MVF

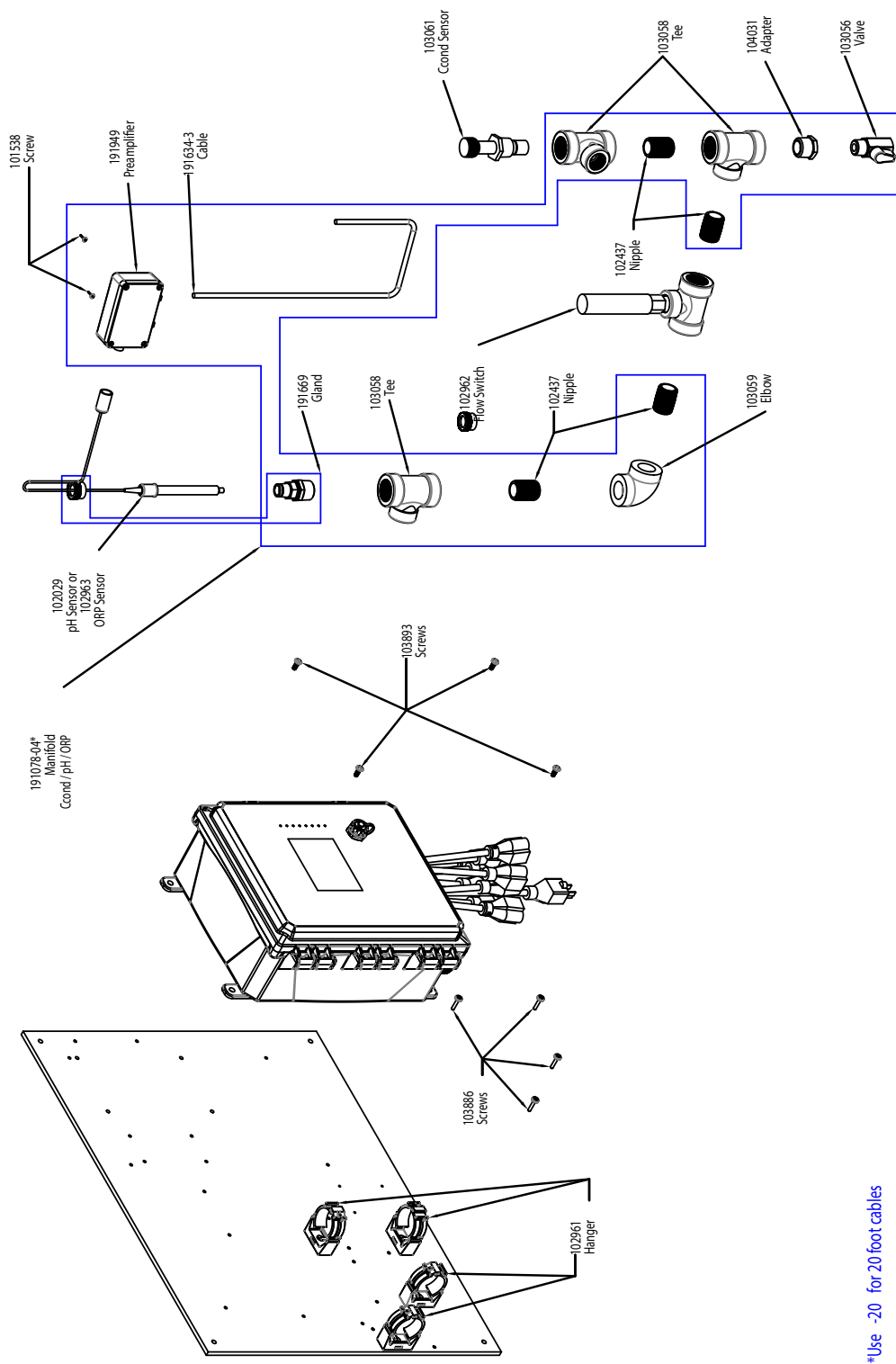
**SO900-IN-PBNNNN:** Flow Switch manifold on panel + WEL-PHF with ATC



\*Use -20 for 20 foot cables

### SOCT900 Sensor Option HDGJNN

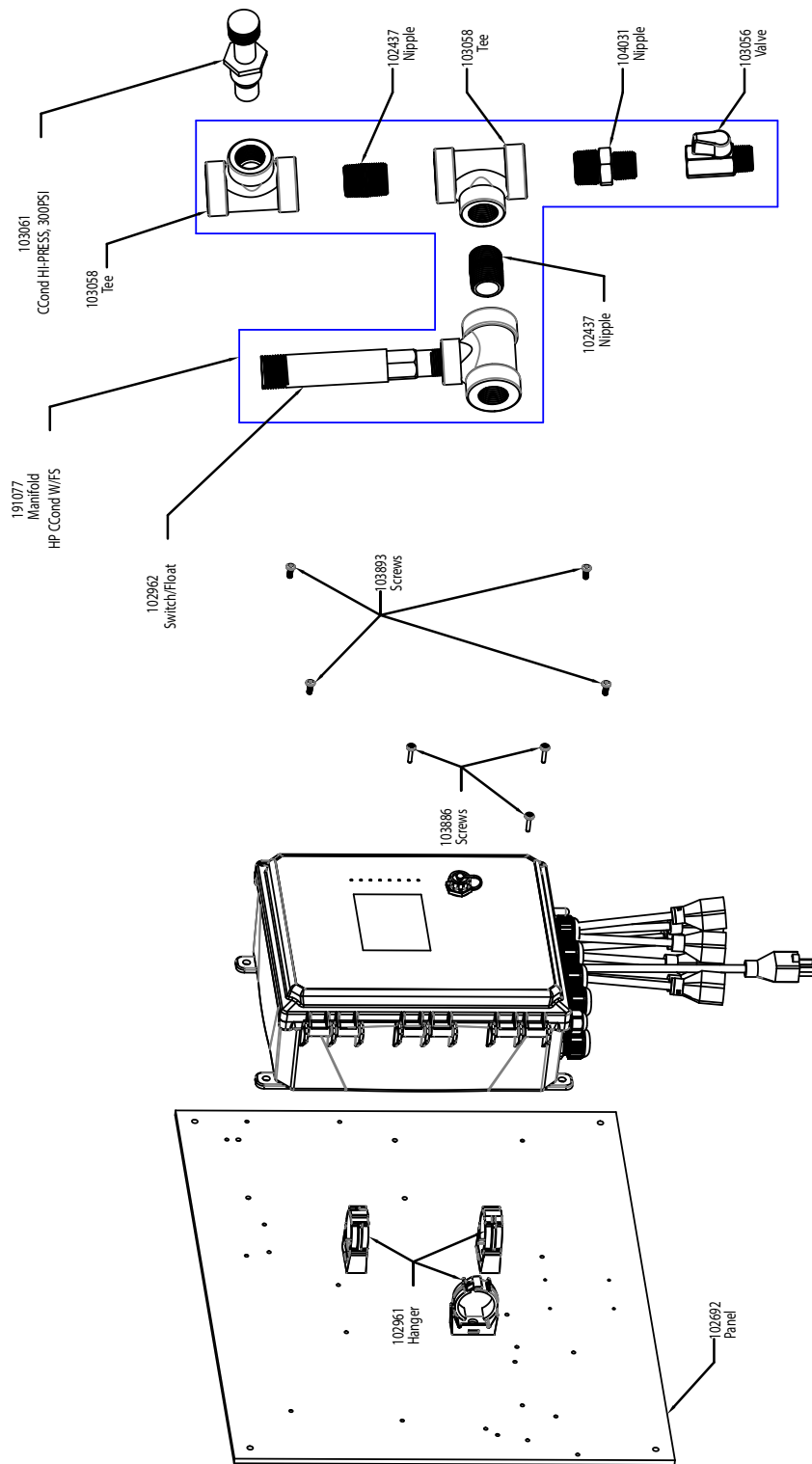
**HDGJNN:** High Pressure conductivity + pH + ORP + Flow Switch manifold on panel



\*Use -20 for 20 foot cables

### SOCT900 Sensor Options HDGNNN, HDJNNN

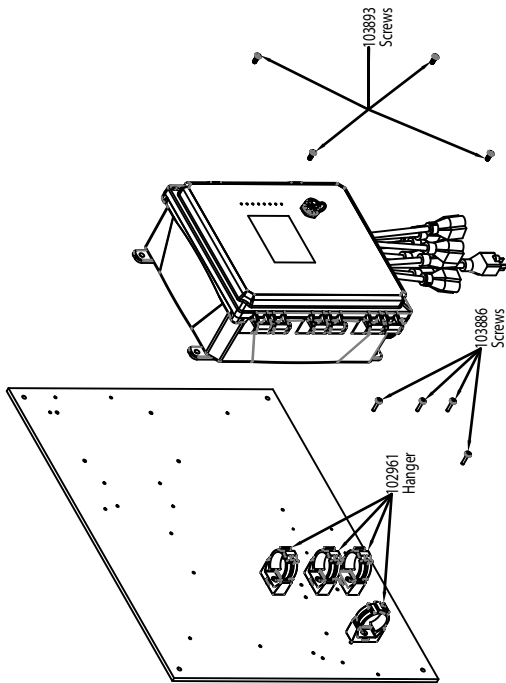
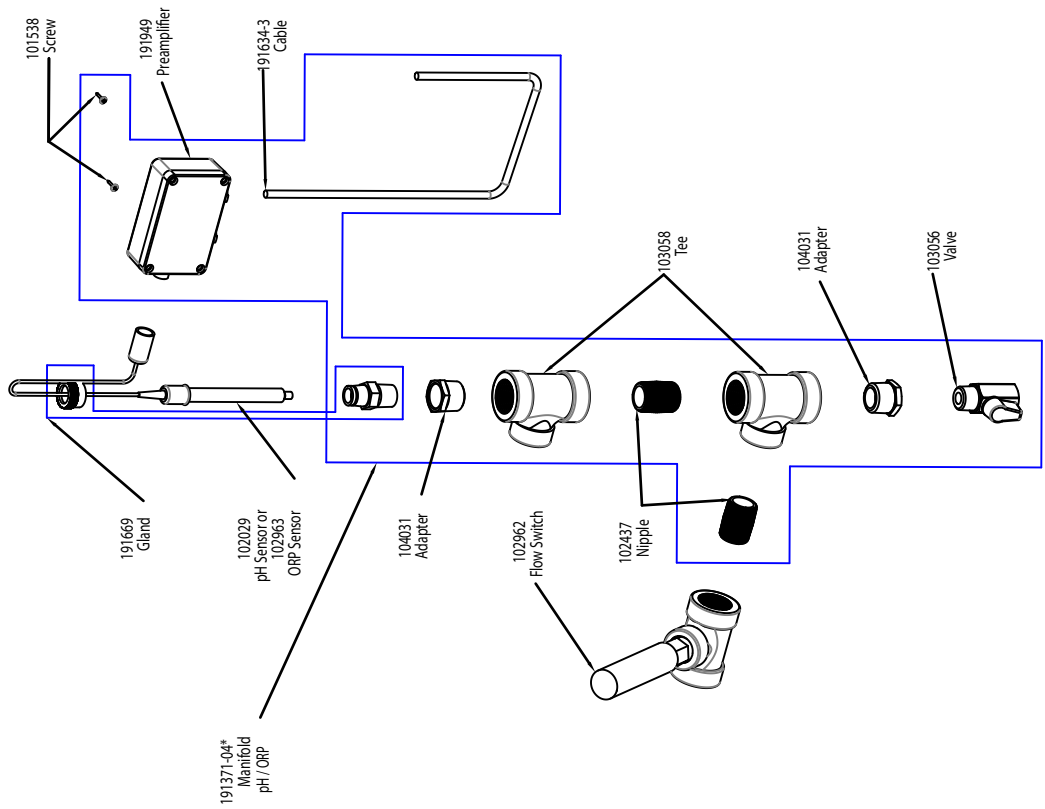
- HDGNNN:** High Pressure Conductivity + pH + Flow Switch manifold on panel
- HDJNNN:** High Pressure Conductivity + ORP + Flow Switch manifold on panel



SOLIDWORKS Educational Product.  
For Instructional Use Only.

## SOCT900 Sensor Option HDNNNN

**HDNNNN:** High Pressure conductivity + Flow Switch manifold on panel

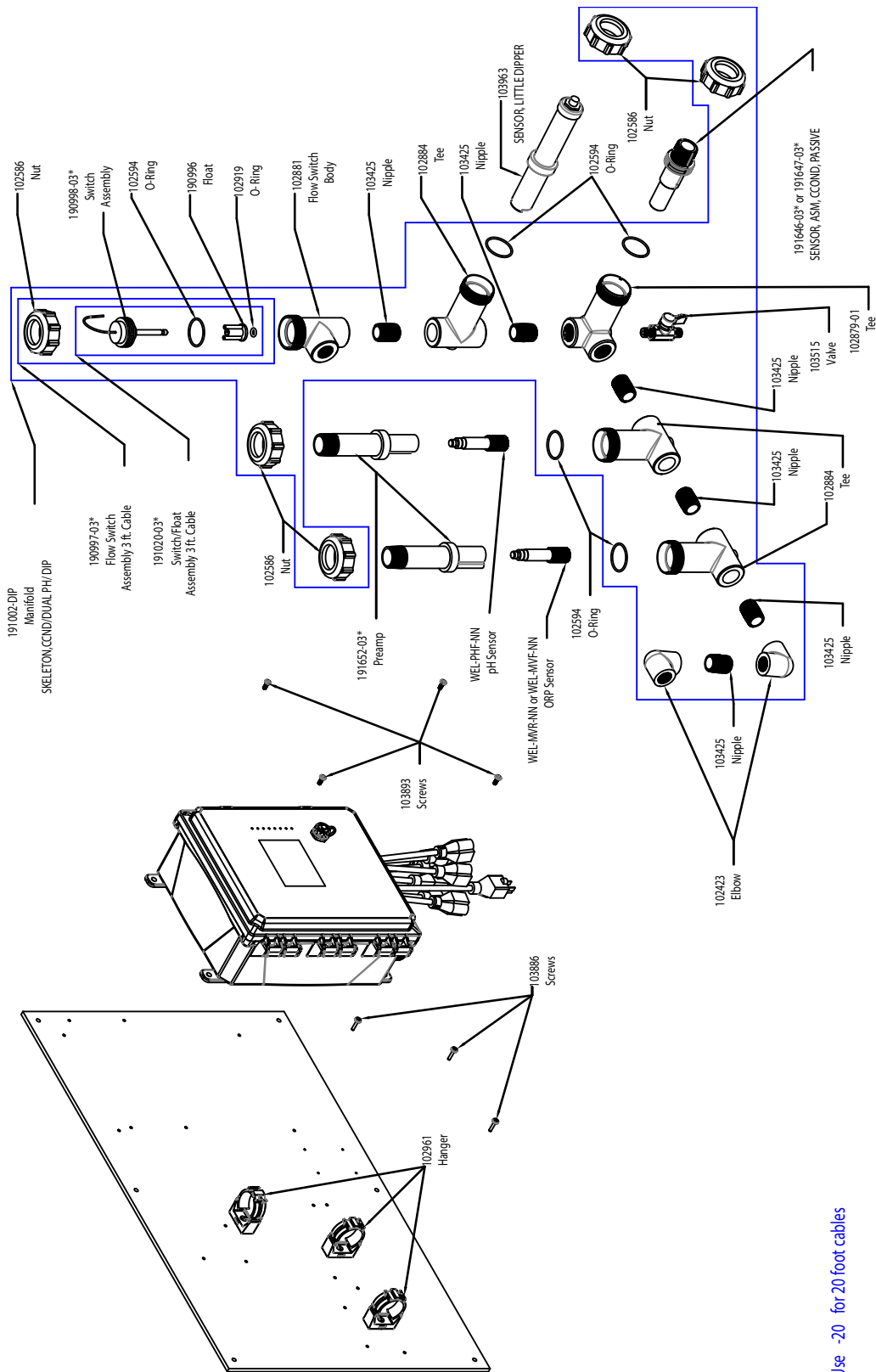


\*Use -20 for 20 foot cables

## SOCT900 Sensor Options HGNNNN, HJNNNN

**HGNNNN:** High Pressure pH + Flow Switch manifold on panel

**HJNNNN:** High Pressure ORP + Flow Switch manifold on panel

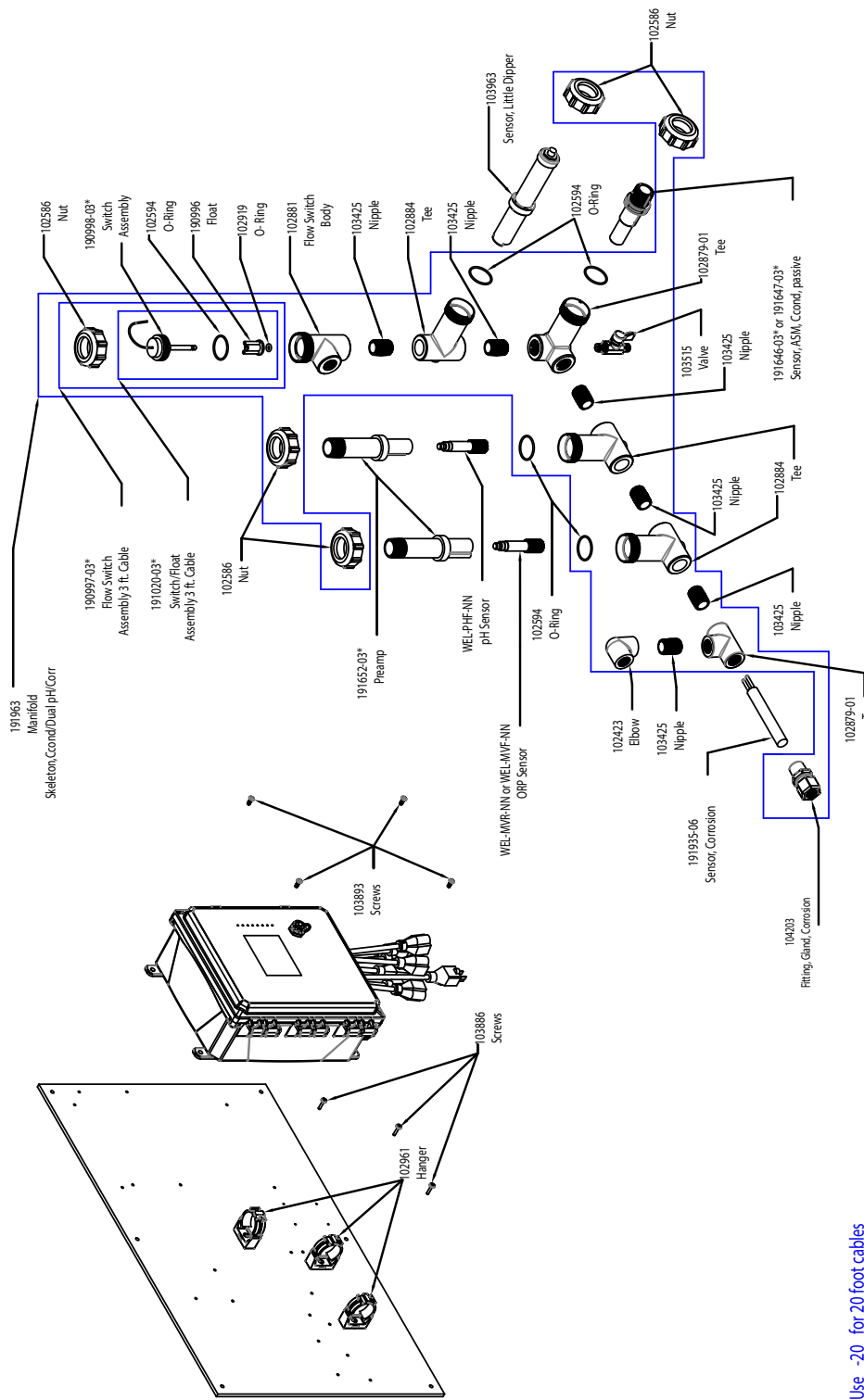


\*Use -20 for 20 foot cables

### SOCT900 Sensor Options PAFHMN, PBFHMN, PAFIMN, PBFIMN

- PAFHMN:** Graphite contacting conductivity + pH + LD2 + Flow Switch manifold on panel + Rod ORP
- PAFIMN:** + Flat ORP
- PBFIMN:** 316SS contacting conductivity + pH + LD2 + Flow Switch manifold on panel + Flat ORP
- PBFHMN:** + Rod ORP

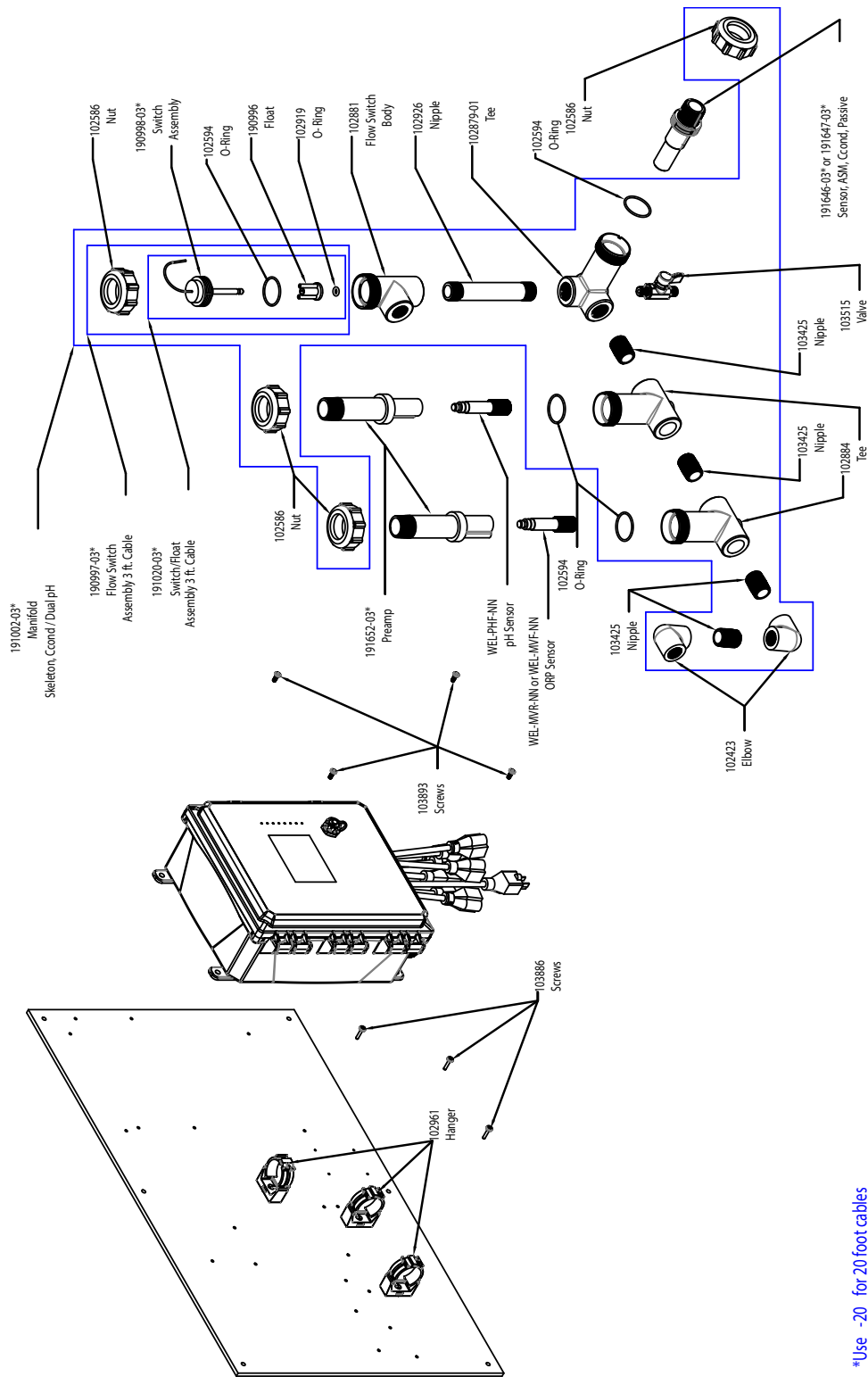




\*Use -20 for 20 foot cables

### SOCT900 Sensor Options PAFHMO, PBFHMO, PAFIMO, PBFIMO

- PAFHMO:** Graphite contacting conductivity + pH + LD2 + Corrosion + Flow Switch manifold on panel + Rod ORP
- PAFIMO:** + Flat ORP
- PBFHMO:** 316SS contacting conductivity + pH + LD2 + Corrosion + Flow Switch manifold on panel + Rod ORP
- PBFIMO:** + Flat ORP



\*Use -20 for 20 foot cables

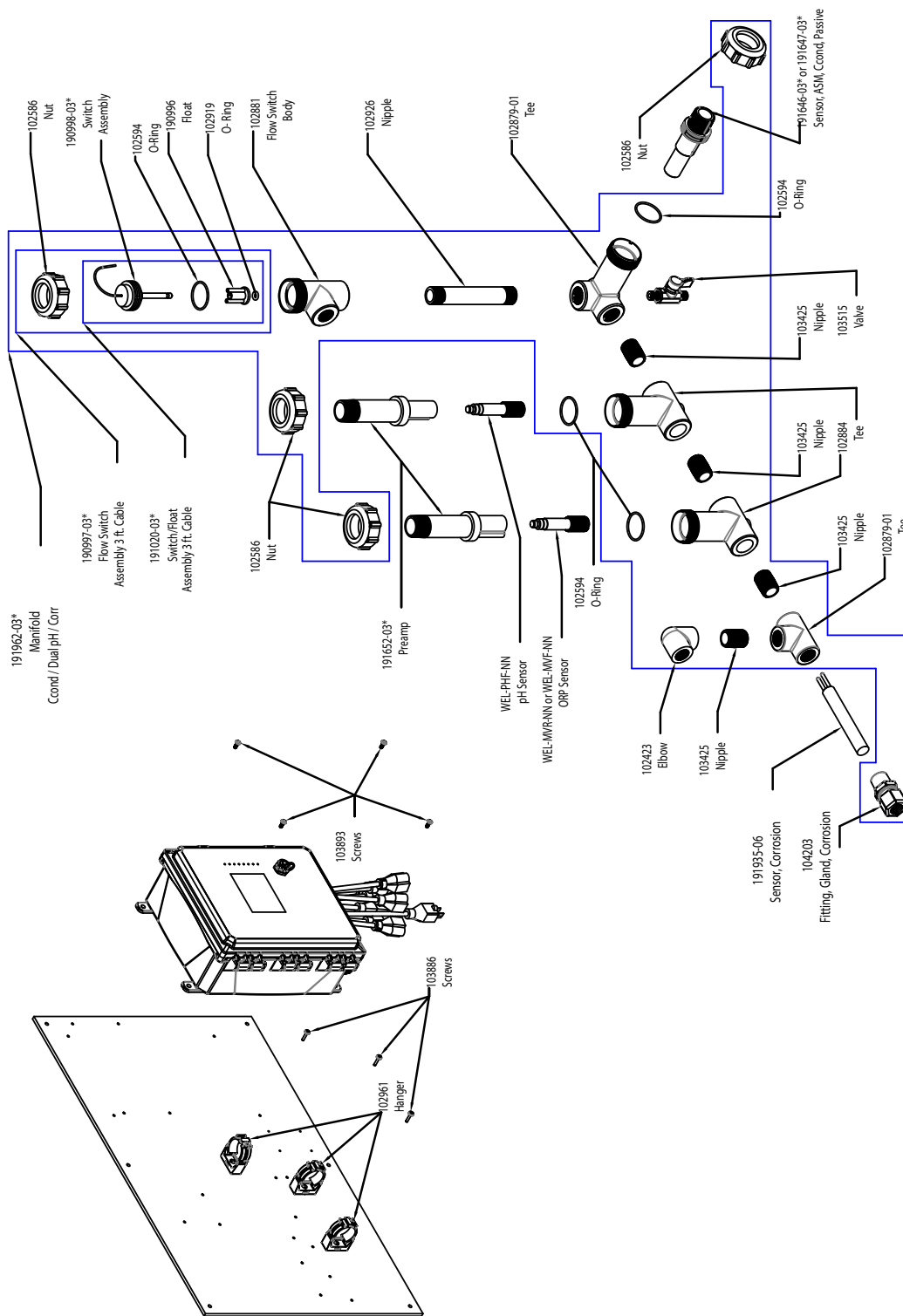
## SOCT900 Sensor Options PAFHNN, PBFHNN, PAFINN, PBFINN

**PAFHNN:** Graphite contacting conductivity + pH + Flow Switch manifold on panel + Rod ORP

**PAFINN:** + Flat ORP

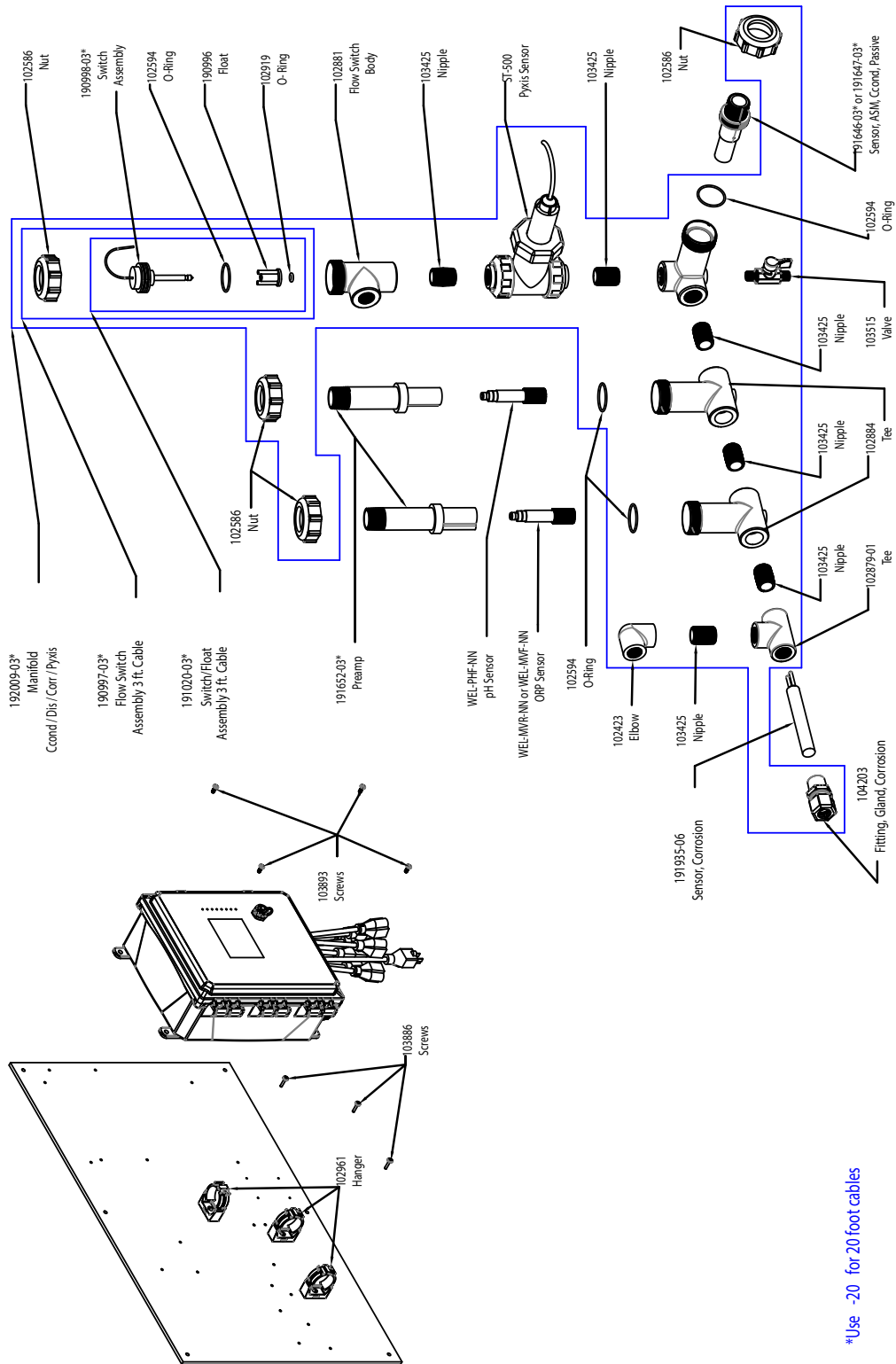
**PBFHNN:** 316SS contacting conductivity + pH + Flow Switch manifold on panel + Rod ORP

**PBFINN:** + Flat ORP



**SOCT900 Sensor Options PAFHON, PBFHON, PAFION, PBFION**

- PAFHON:** Graphite contacting conductivity + pH + Corrosion + Flow Switch manifold on panel + Rod ORP
- PAFION:** + Flat ORP
- PBFHON:** 316SS contacting conductivity + pH + Corrosion + Flow Switch manifold on panel + Rod ORP
- PBFION:** + Flat ORP



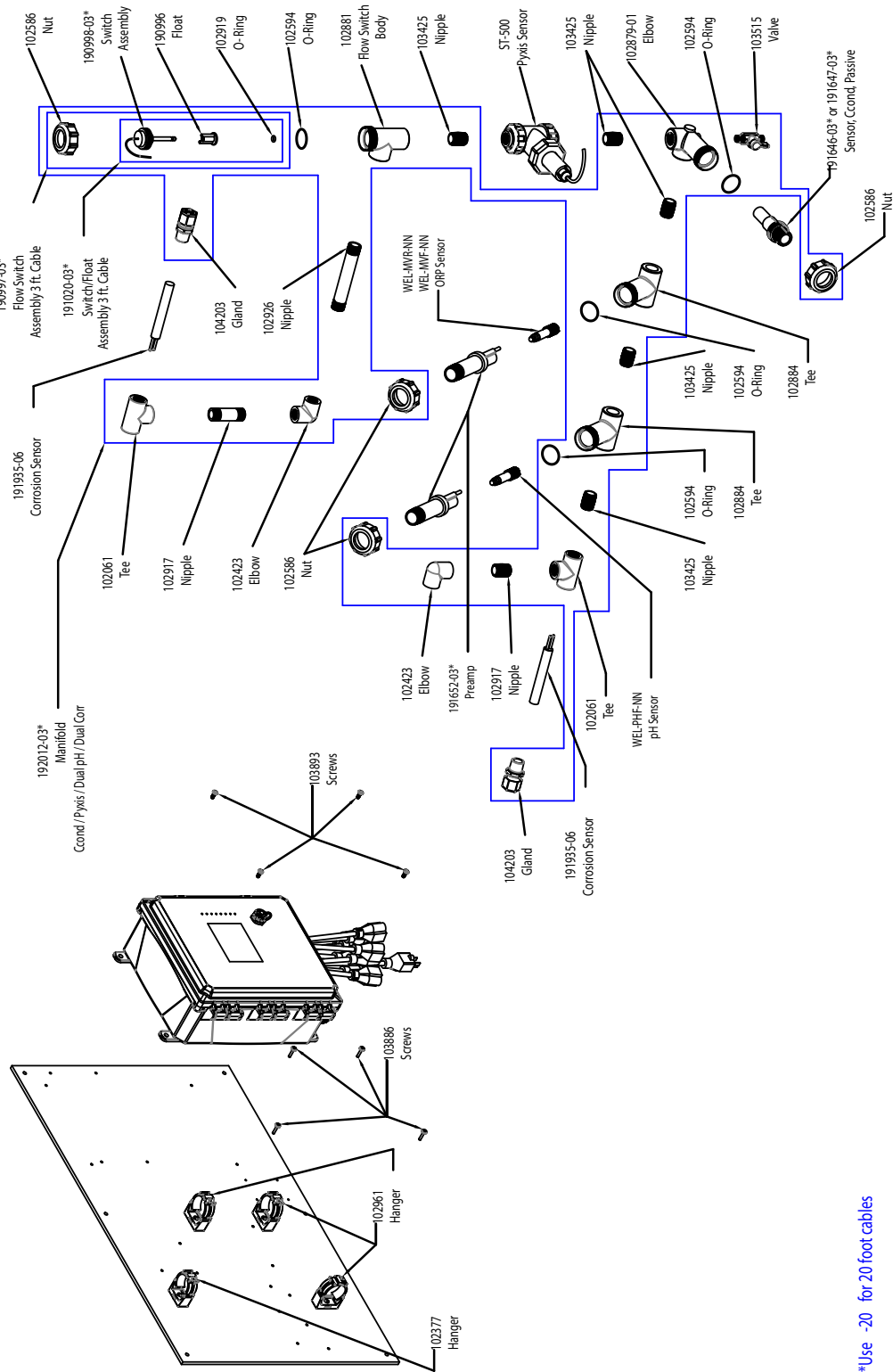
## SOCT900 Sensor Options PAFHOP, PBFHOP, PAFIOP, PBFIOP

**PAFHOP:** Graphite contacting conductivity + pH + Corrosion + Pyxis + Flow Switch manifold on panel + Rod ORP

**PAFIOP:** + Flat ORP

**PBFHOP:** 316SS contacting conductivity + pH + Corrosion + Pyxis + Flow Switch manifold on panel + Rod ORP

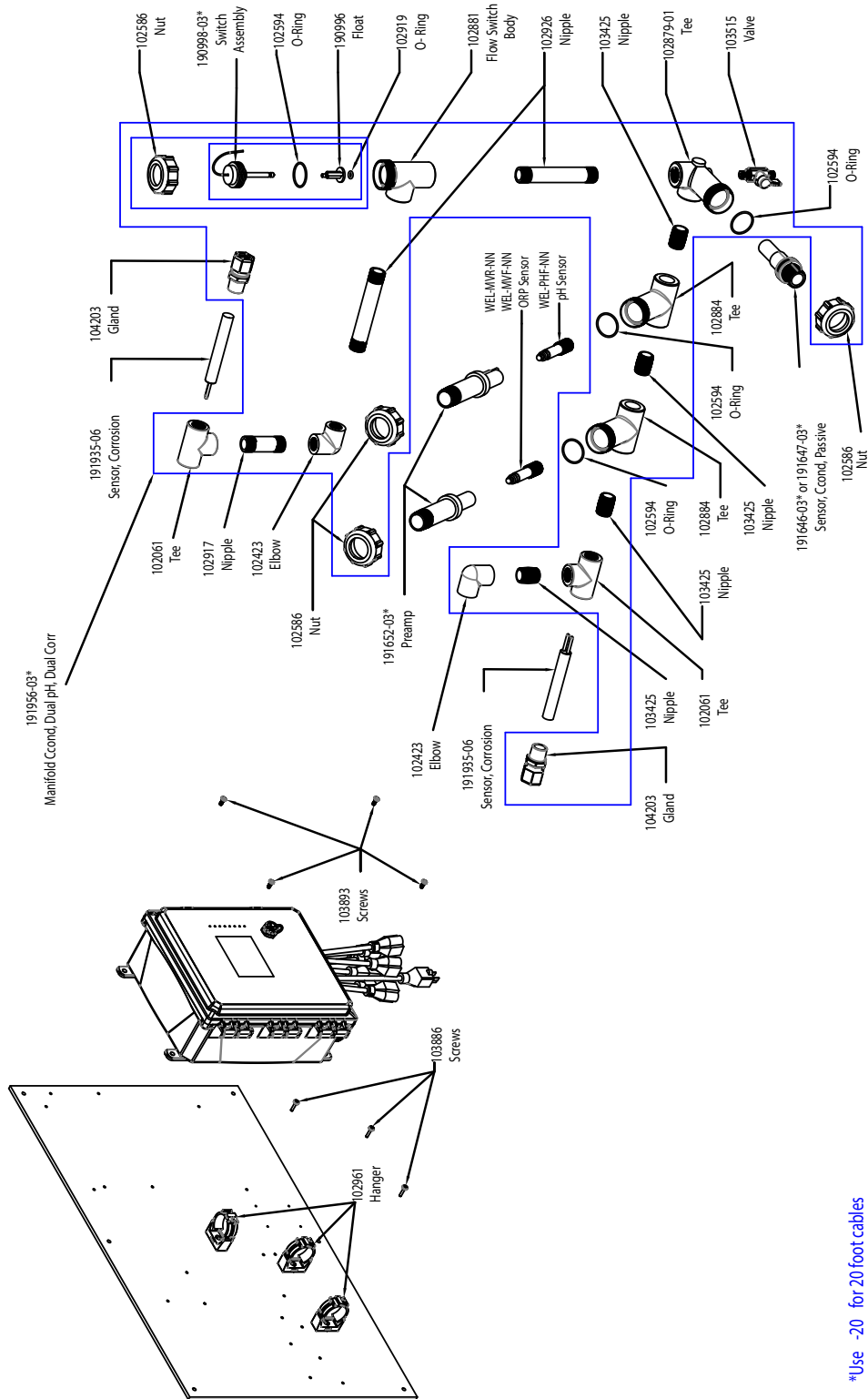
**PBFIOP:** + Flat ORP



\*Use -20 for 20 foot cables

### SOCT900 Sensor Options PAFHPR, PBFHPR, PAFIPR, PBFIPR

- PAFHPR:** Graphite contacting conductivity + pH + Dual Corrosion + Pyxis + Flow Switch manifold on panel + Rod ORP
- PAFIPR:** + Flat ORP
- PBFHPR:** 316SS contacting conductivity + pH + Dual Corrosion + Pyxis + Flow Switch manifold on panel + Rod ORP
- PBFIPR:** + Flat ORP



\*Use -20 for 20 foot cables

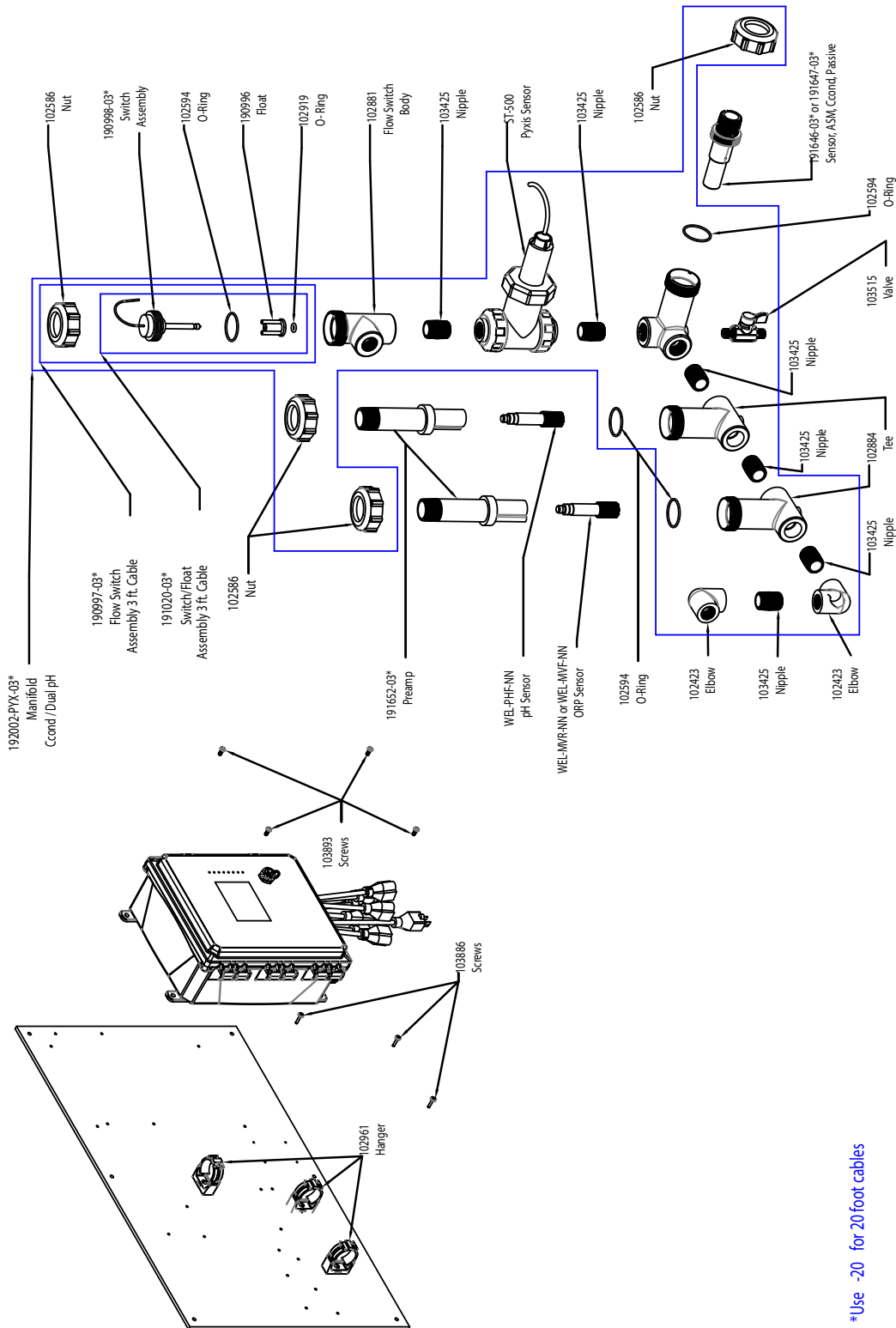
## SOCT90 Sensor Options PAFHRN, PBFHRN, PAFIRN, PBFIRN

**PAFHRN:** Graphite contacting conductivity + pH + Dual Corrosion + Flow Switch manifold on panel  
+ Rod ORP

**PAFIRN:** + Flat ORP

**PBFHRN:** 316SS contacting conductivity + pH + Dual Corrosion + Flow Switch manifold on panel  
+ Rod ORP

**PBFIRN:** + Flat ORP



\*Use -20 for 20 foot cables

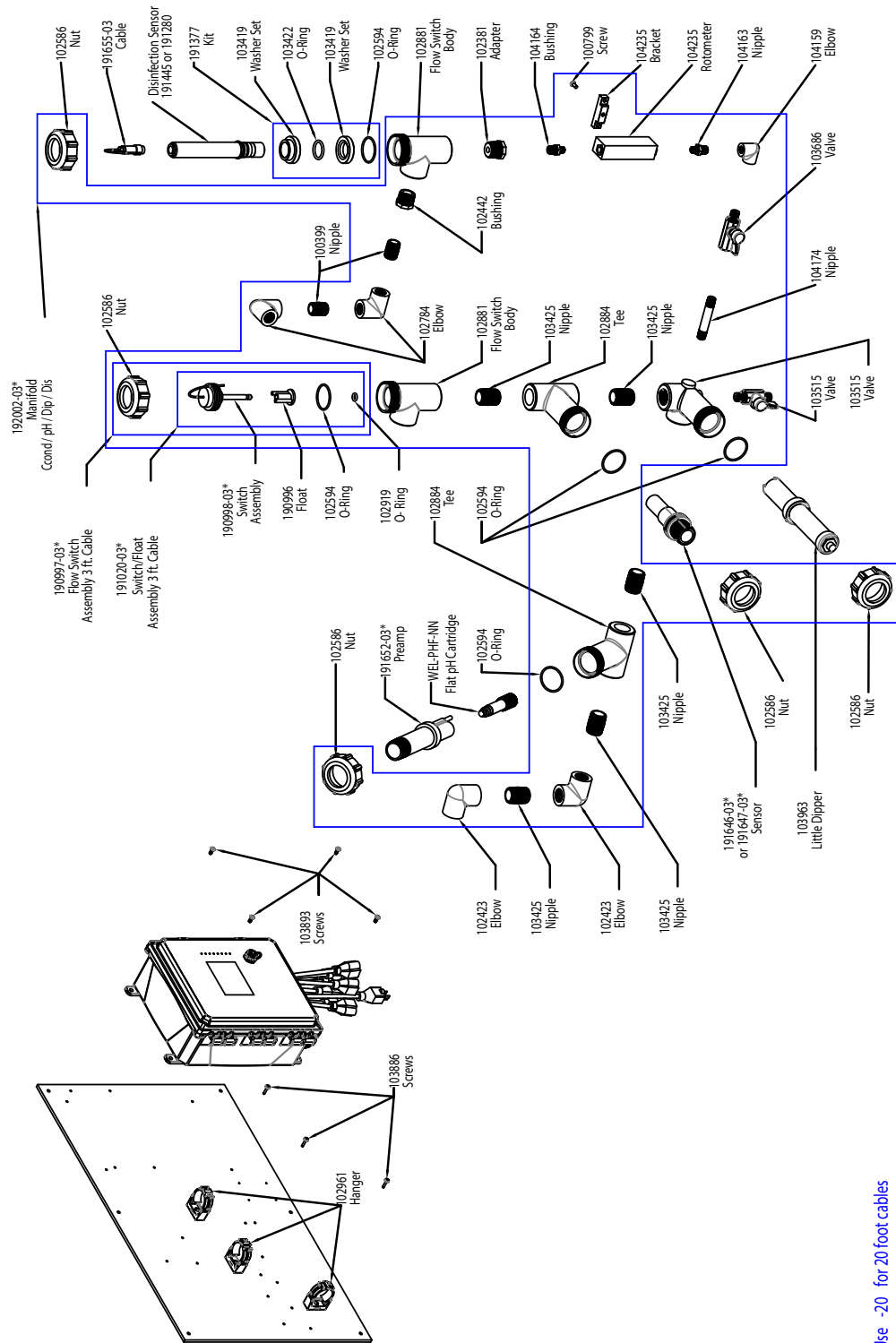
## SOCT900 Sensor Options PAFHPN, PBFHPN, PAFIPN, PBFIPN

**PAFHPN:** Graphite contacting conductivity + pH + Pyxis + Flow Switch manifold on panel + Rod ORP

**PAFIPN:** + Flat ORP

**PBFHPN:** 316SS contacting conductivity + pH + Pyxis + Flow Switch manifold on panel + Rod ORP

**PBFIPN:** + Flat ORP



## SOCT90 Sensor Options PAFKMN, PBFKMN, PAFLMN, PBFLMN

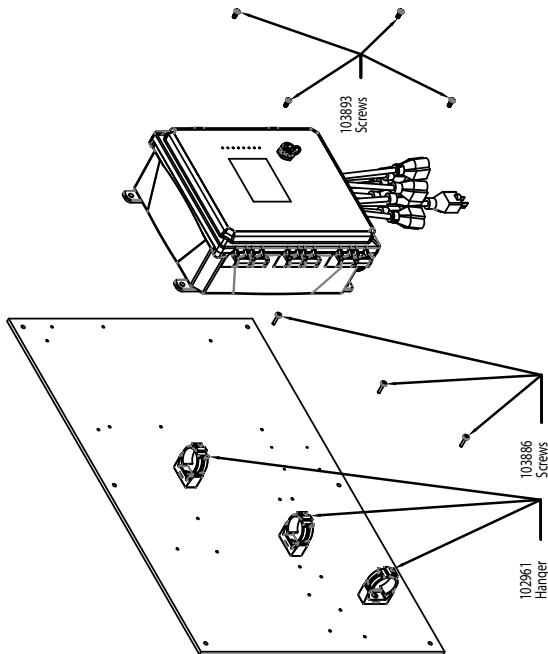
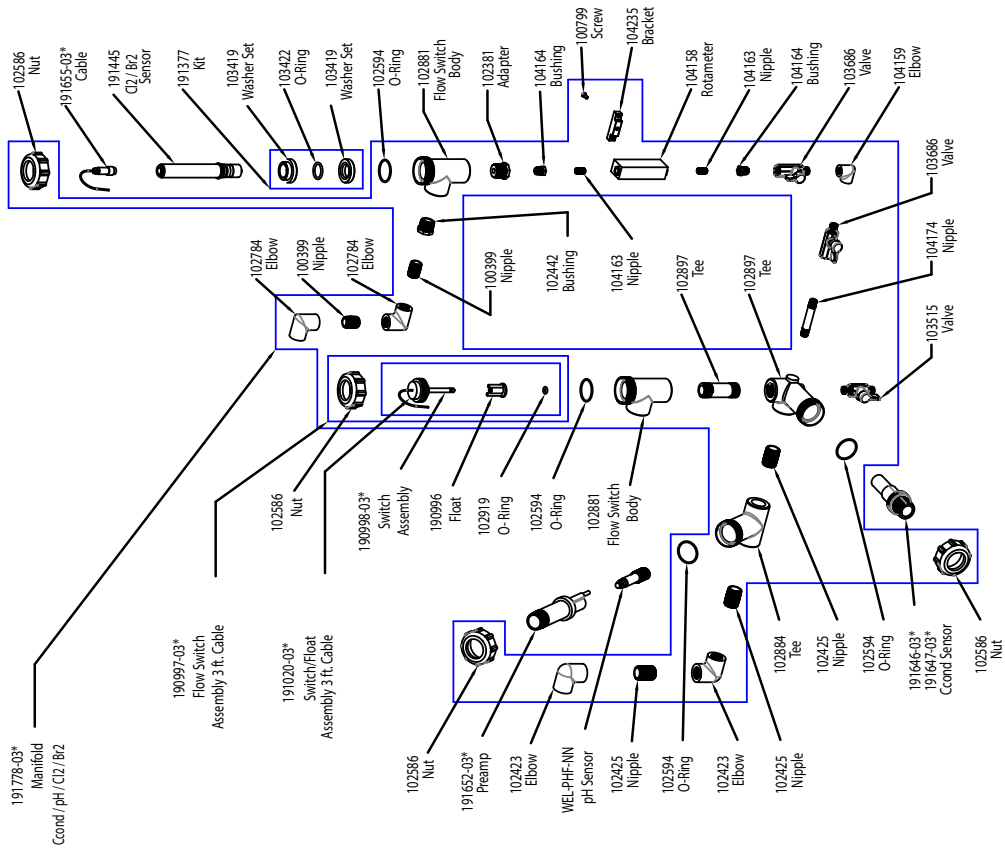
**PAFKMN:** Graphite contacting conductivity + pH + LD2 + Flow Switch manifold on panel + Chlorine

**PAFLMN:** + Chlorine Dioxide

**PBFKMN:** 316SS contacting conductivity + pH + LD2 + Flow Switch manifold on panel + Chlorine

**PBFLMN:** + Chlorine Dioxide





\*Use -20 for 20 foot cables

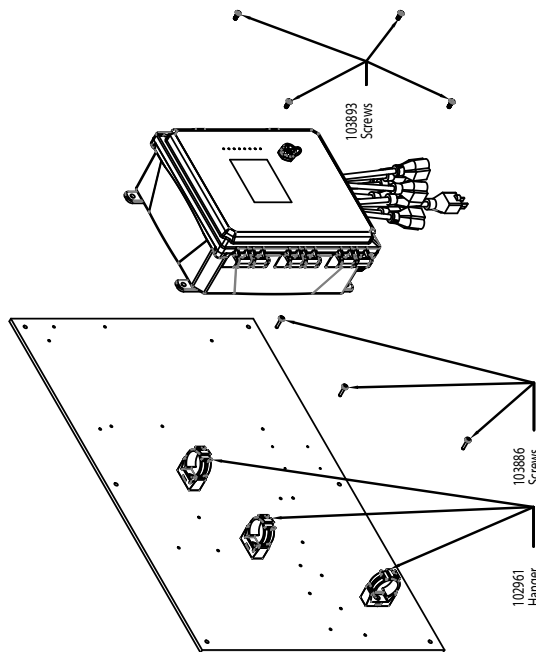
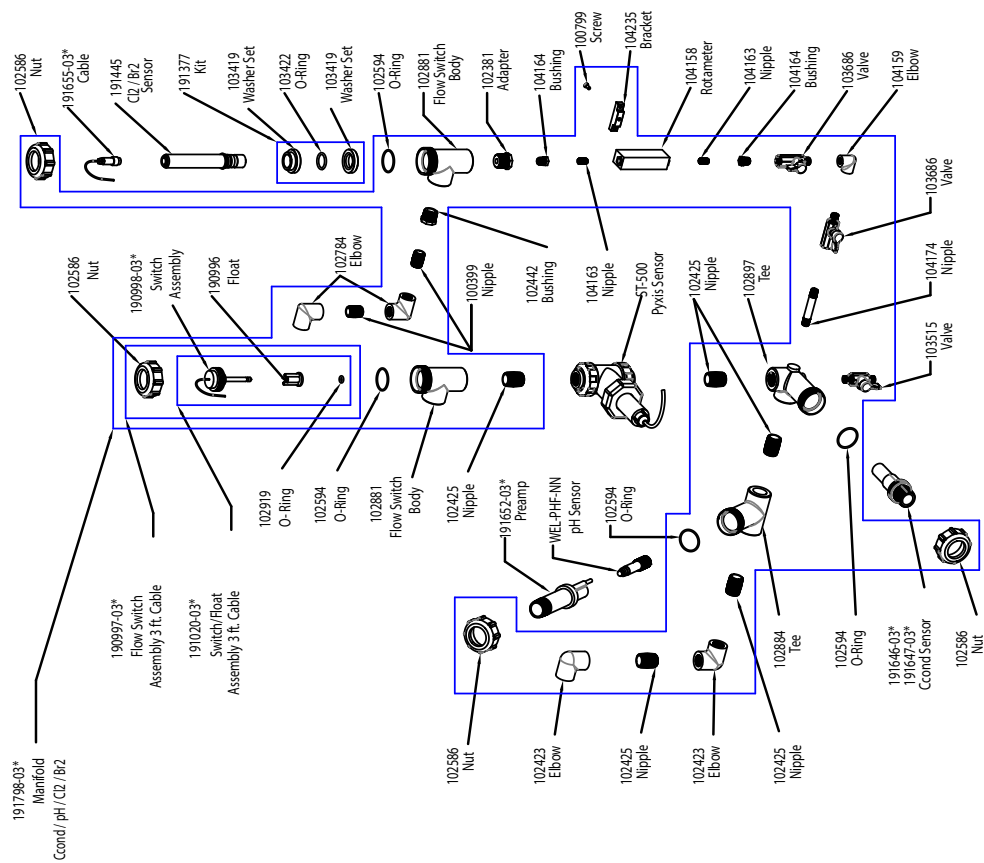
## SOCT900 Sensor Options PAFKNN, PBFKNN, PAFLNN, PBFLNN

**PAFKNN:** Graphite contacting conductivity + pH + Flow Switch manifold on panel + Chlorine

**PAFLNN:** + Chlorine Dioxide

**PBFKNN:** 316SS contacting conductivity + pH + Flow Switch manifold on panel + Chlorine

**PBFLNN:** + Chlorine Dioxide



\*Use -20 for 20 foot cables

## SOCT900 Sensor Options PAFKPN, PBFKPN, PAFLPN, PBFLPN

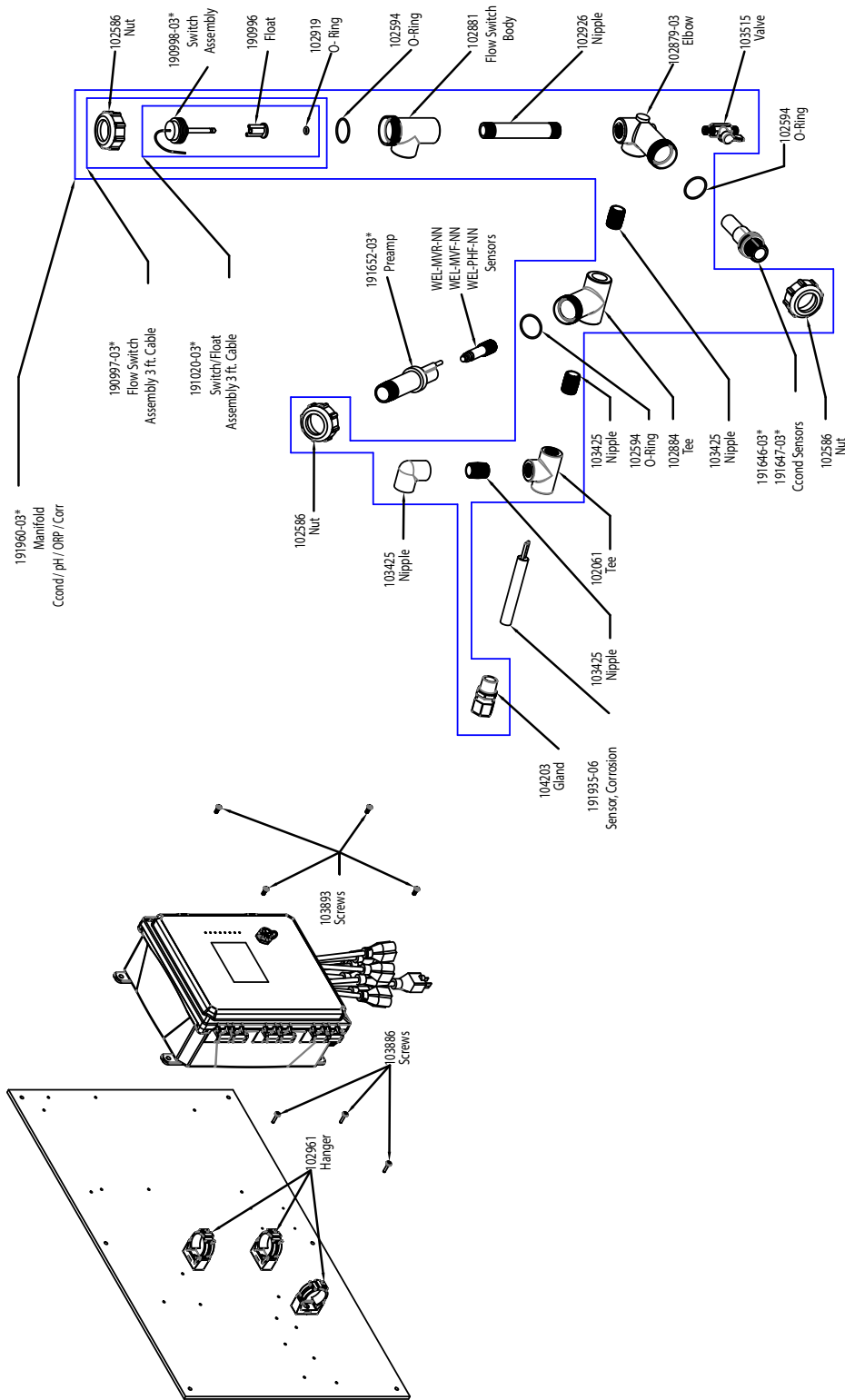
**PAFKPN:** Graphite contacting conductivity + pH + Pyxis + Flow Switch manifold on panel + Chlorine

**PAFLPN:** + Chlorine Dioxide

**PBFKPN:** 316SS contacting conductivity + pH + Pyxis + Flow Switch manifold on panel + Chlorine

**PBFLPN:** + Chlorine Dioxide





\*Use -20 for 20 foot cables

### SOCT900 Sensor Options PAFONN, PBFONN, PAHONN, PBHONN, PAIONN, PBIONN

**PAFONN:** Graphite contacting conductivity + Corrosion + Flow Switch manifold on panel + pH

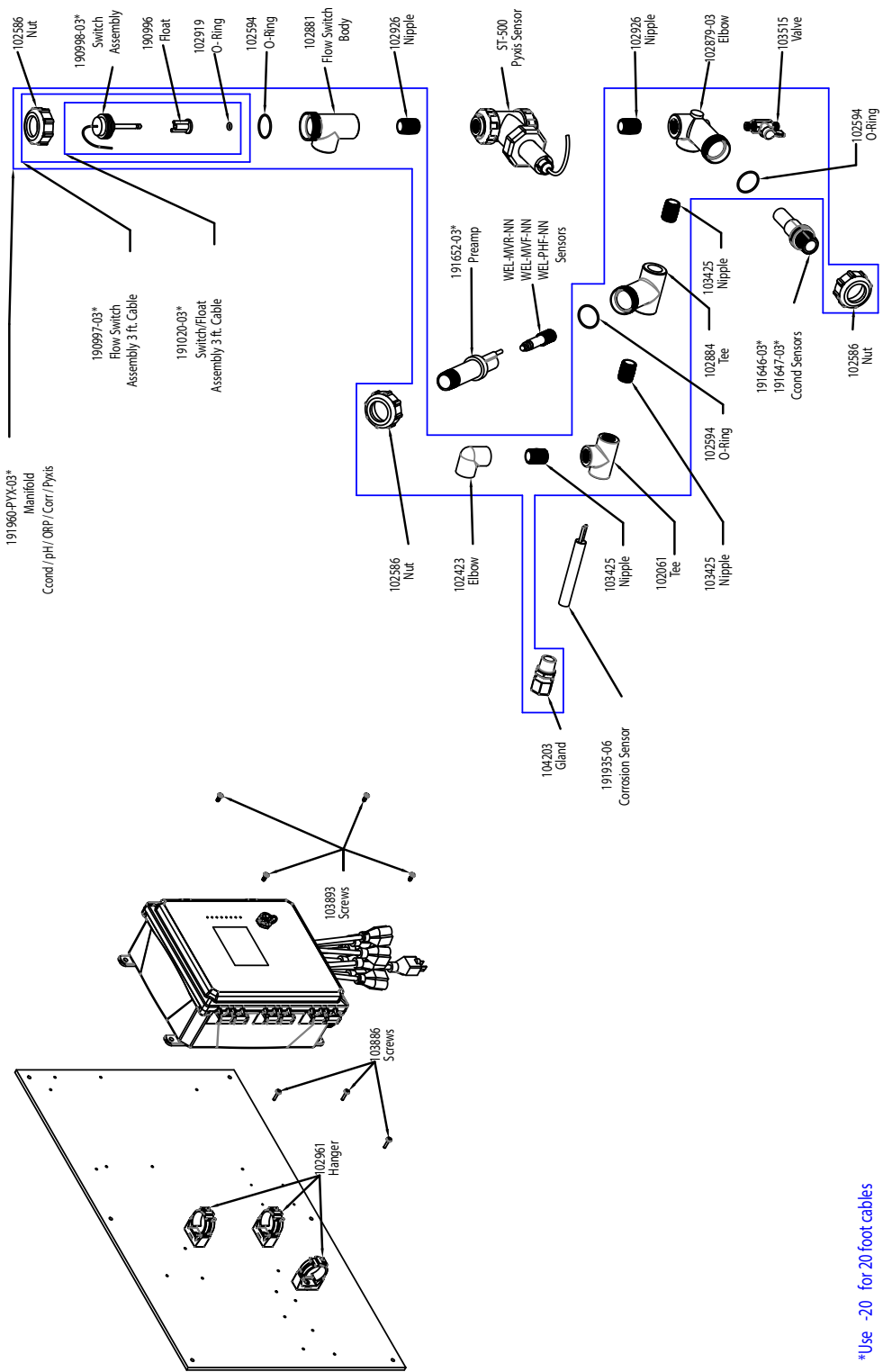
**PAHONN:** + Rod ORP

**PAIONN:** + Flat ORP

**PBFONN:** 316SS contacting conductivity + Corrosion + Flow Switch manifold on panel + pH

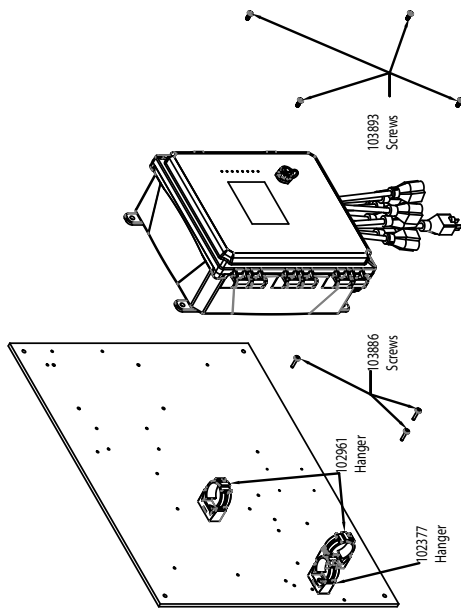
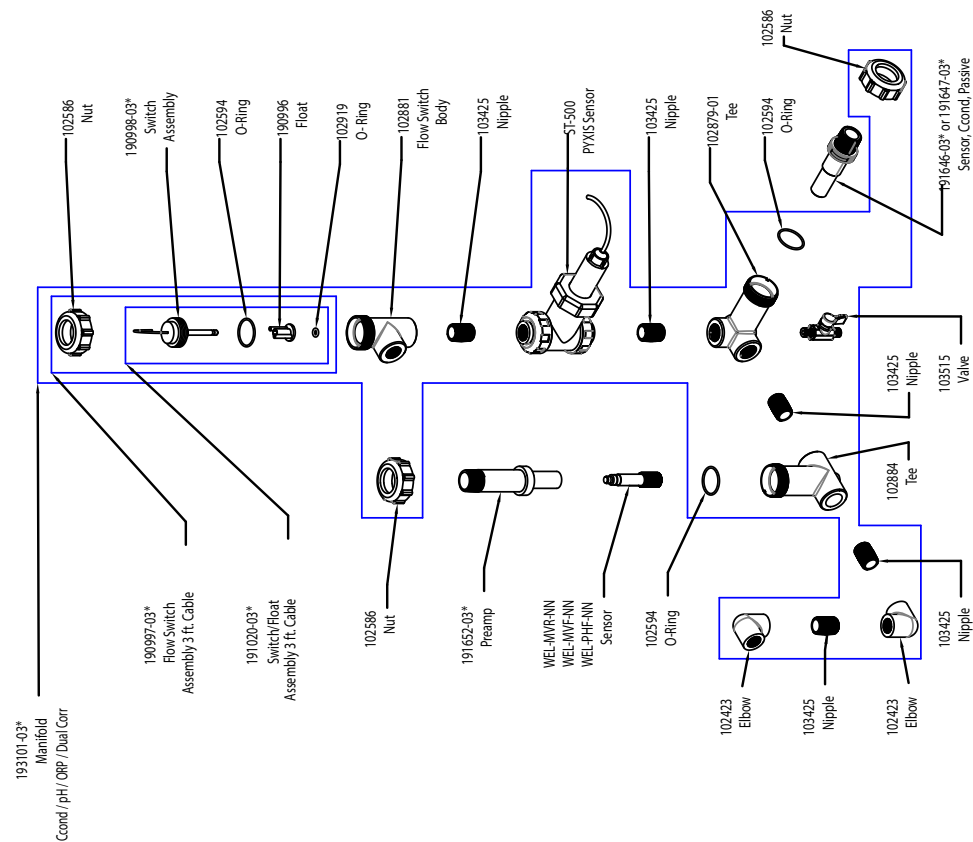
**PBHONN:** + Rod ORP

**PBIONN:** + Flat ORP



**SOCT900 Sensor Options PAFOPN, PBFOPN, PAHOPN, PBHOPN, PAIOPN, PBIOPN**

- PAFOPN:** Graphite contacting conductivity + Corrosion + Pyxis + Flow Switch manifold on panel + pH
- PAHOPN:** + Rod ORP
- PAIOPN:** + Flat ORP
- PBFOPN:** 316SS contacting conductivity + Corrosion + Pyxis + Flow Switch manifold on panel + pH
- PBHOPN:** + Rod ORP
- PBIOPN:** + Flat ORP



\*Use -20 for 20 foot cables

## SOCT900 Sensor Options PAFPNN, PBFNN, PAHPNN, PBHPNN, PAIPNN, PBIPNN

**PAFPNN:** Graphite contacting conductivity + Pyxis + Flow Switch manifold on panel + pH

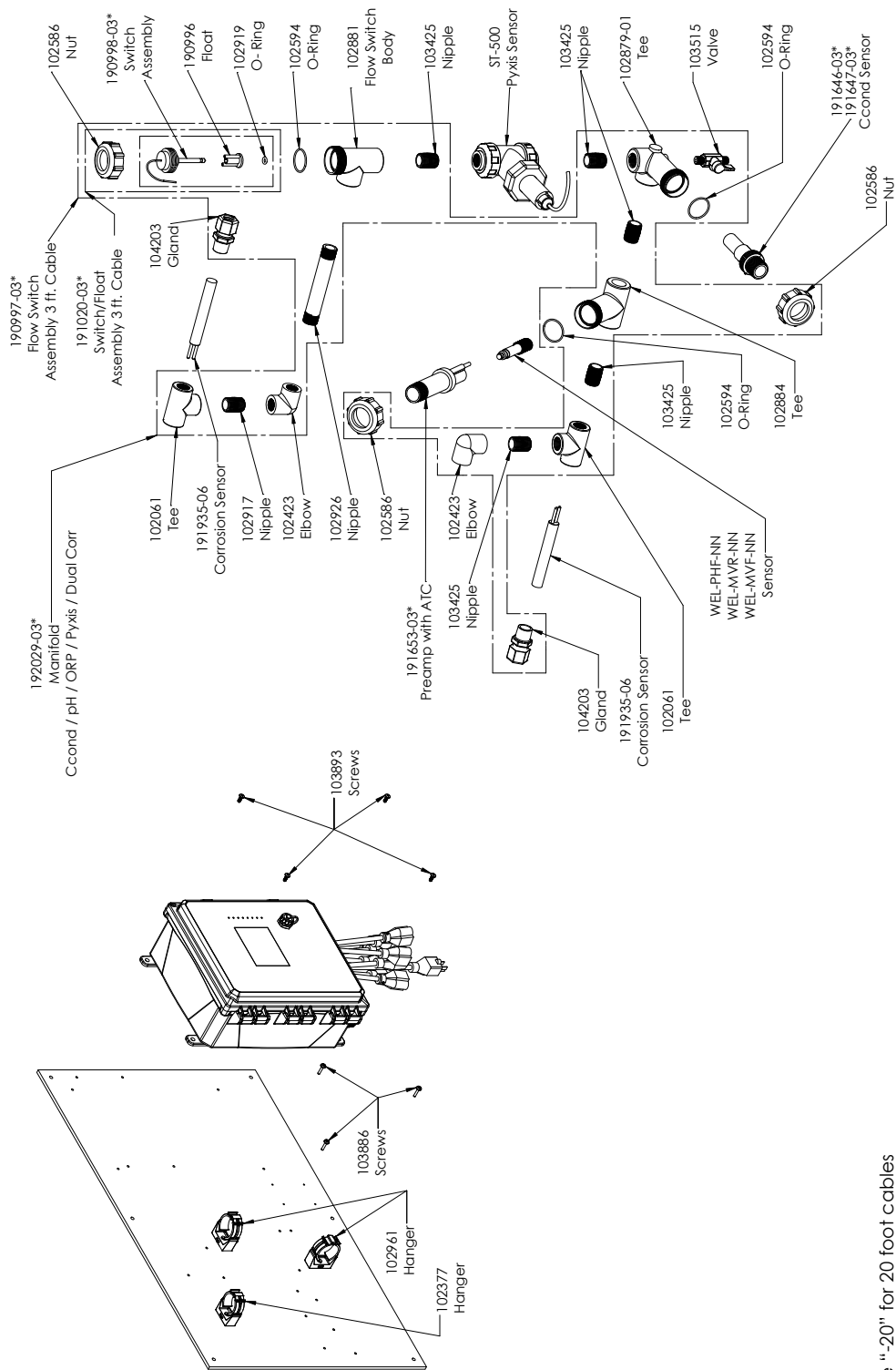
**PAHPNN:** + Rod ORP

**PAIPNN:** + Flat ORP

**PBFNN:** 316SS contacting conductivity + Pyxis + Flow Switch manifold on panel + pH

**PBHPNN:** + Rod ORP

**PBIPNN:** + Flat ORP



\*Use ".20" for 20 foot cables

### SOCT900 Sensor Options PAFPRN, PBFPRN, PAHPRN, PBHPRN, PAIPRN, PBIPRN

**PAFPRN:** Graphite contacting conductivity + Dual Corrosion + Pyxis + Flow Switch manifold on panel + pH

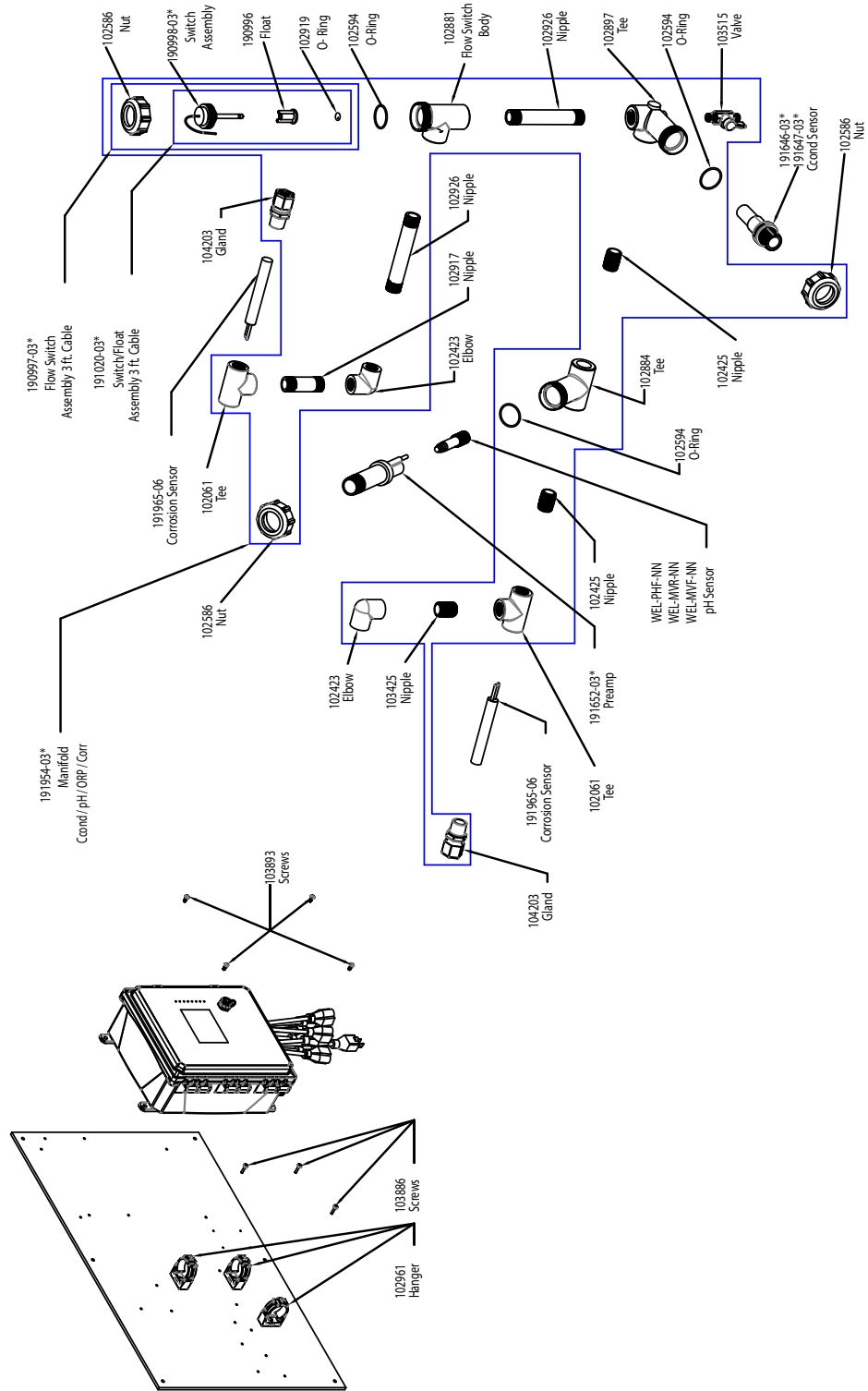
**PAHPRN:** + Rod ORP

**PAIPRN:** + Flat ORP

**PBFPRN:** 316SS contacting conductivity + Dual Corrosion + Pyxis + Flow Switch manifold on panel + pH

**PBHPRN:** + Rod ORP

**PBIPRN:** + Flat ORP



\*Use -20 for 20 foot cables

### SOCT900 Sensor Options PAFRNN, PBFRNN, PAHRNN, PBHRNN, PAIRNN, PBIRNN

**PAFRNN:** Graphite contacting conductivity + Dual Corrosion + Flow Switch manifold on panel + pH

**PAHRNN:** + Rod ORP

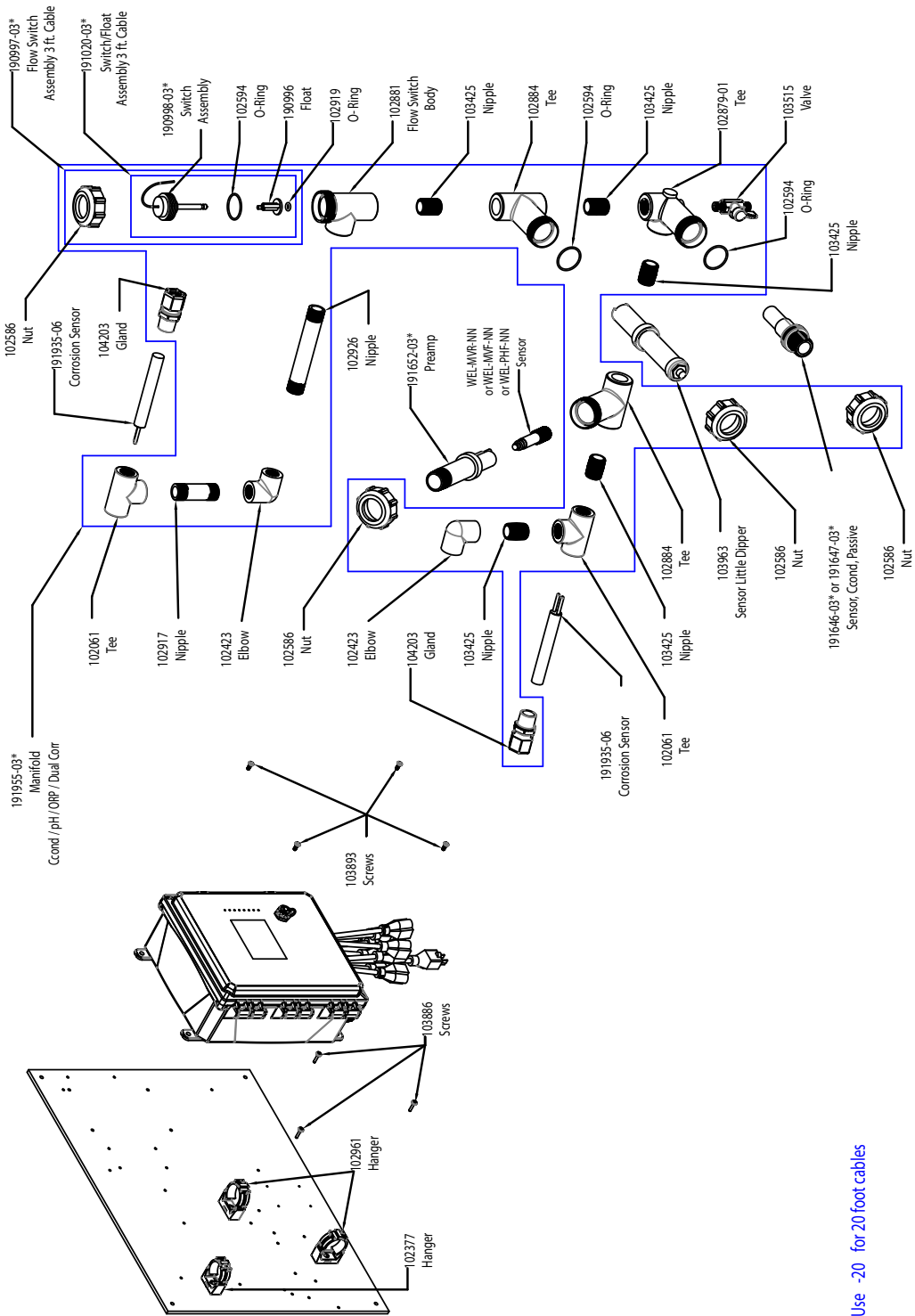
**PAIRNN:** + Flat ORP

**PBFRNN:** 316SS contacting conductivity + Dual Corrosion + Flow Switch manifold on panel + pH

**PBHRNN:** + Rod ORP

**PBIRNN:** + Flat ORP





\*Use -20 for 20 foot cables

## SO900 Sensor Options PAFMRN, PBFMRN, PAHMRN, PBHMRN, PAIMRN, PBIMRN

**PAFMRN:** Graphite contacting conductivity + LD2 + Dual Corrosion + Flow Switch manifold on panel + pH

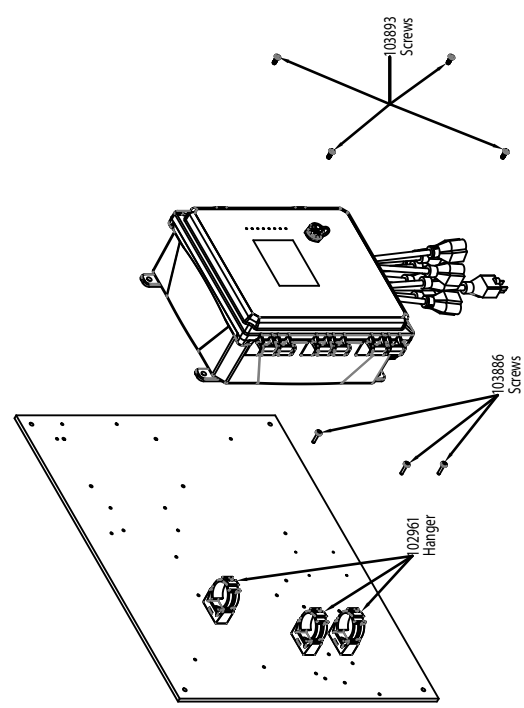
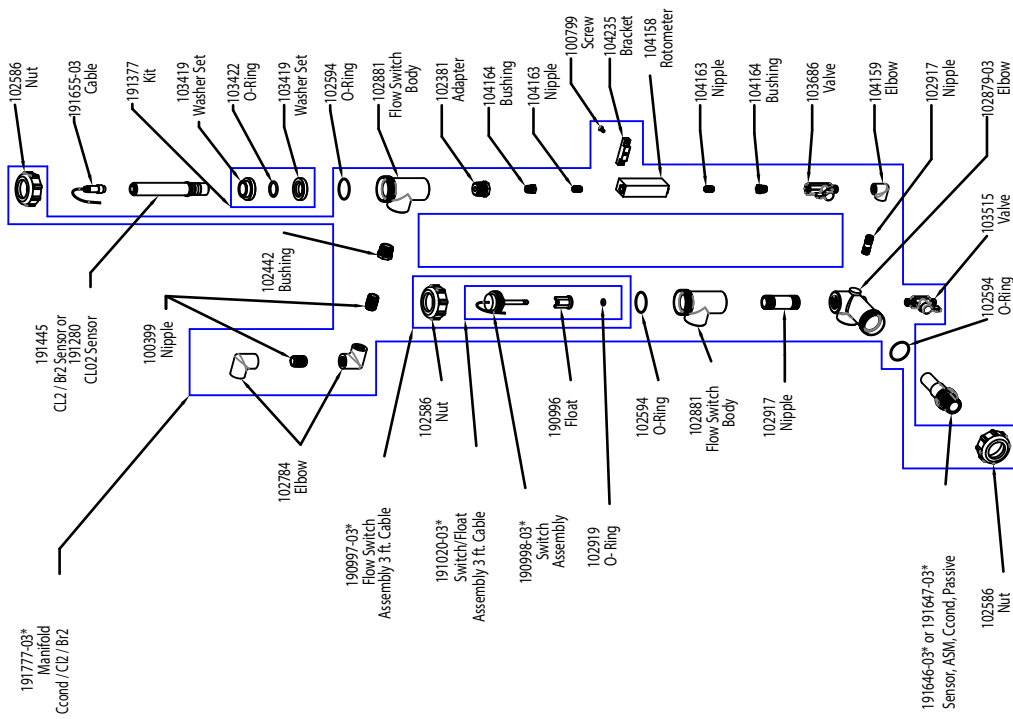
**PAHMRN:** + Rod ORP

**PAIMRN:** + Flat ORP

**PBFMRN:** 316SS contacting conductivity + LD2 + Dual Corrosion + Flow Switch manifold on panel + pH

**PBHMRN:** + Rod ORP

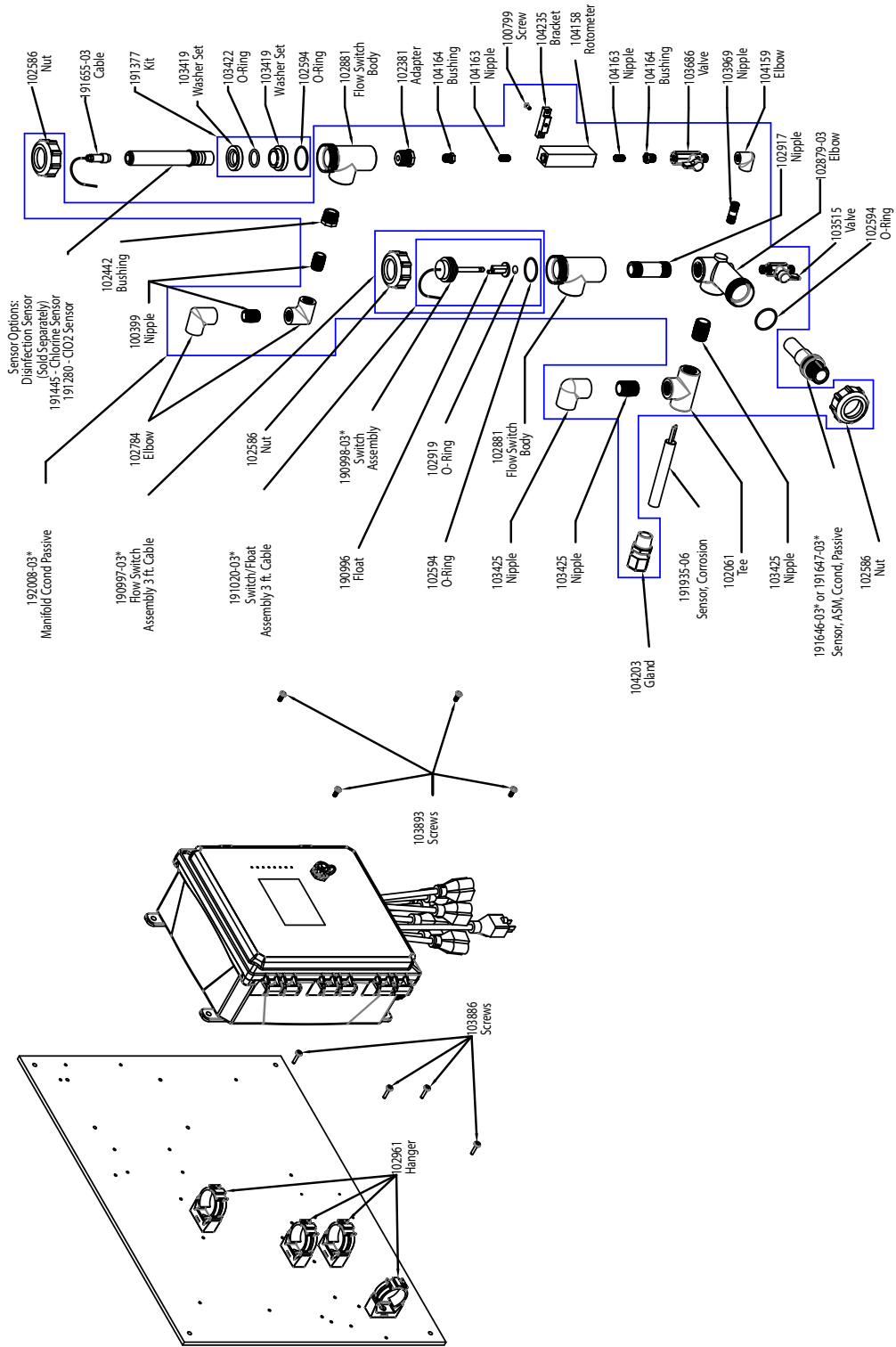
**PBIMRN:** + Flat ORP



\*Use -20 for 20 foot cables

### SO900 Sensor Options PAKNNN, PBKNNN, PALNNN, PBLNNN

- PAKNNN:** Graphite contacting conductivity + Flow Switch manifold on panel + Chlorine
- PALNNN:** + Chlorine Dioxide
- PBKNNN:** 316SS contacting conductivity + Flow Switch manifold on panel + Chlorine
- PBLNNN:** + Chlorine Dioxide



## SOCT900 Sensor Options PAKONN, PBKONN, PALONN, PBLONN, PAOSNN

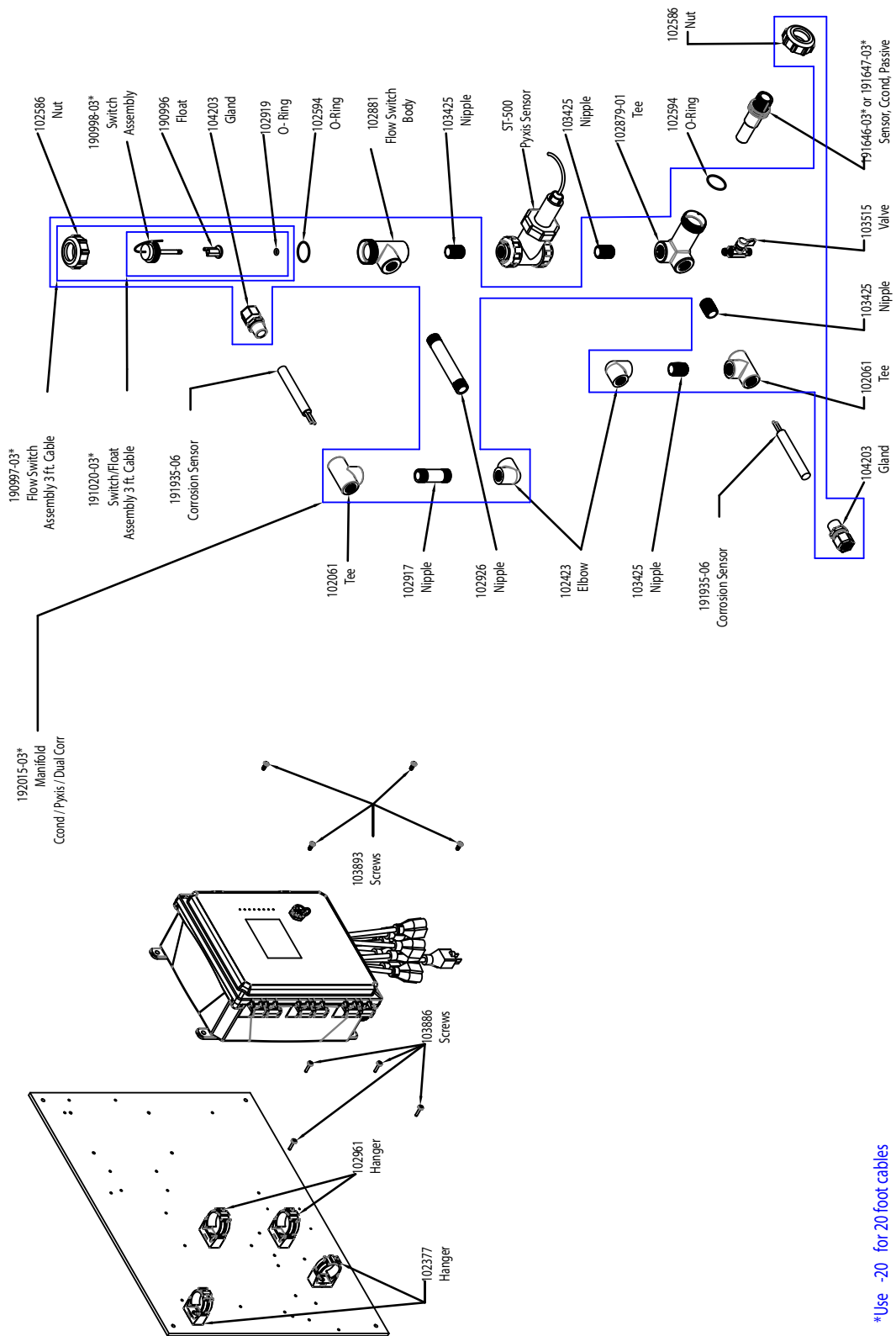
**PAKONN:** Graphite contacting conductivity + Flow Switch manifold on panel + Chlorine + Corrosion

**PBKONN:** 316SS contacting conductivity + Flow Switch manifold on panel + Chlorine + Corrosion

**PALONN:** Graphite contacting conductivity + Flow Switch manifold on panel + ClO2 + Corrosion

**PBLONN:** 316SS contacting conductivity + Flow Switch manifold on panel + ClO2 + Corrosion

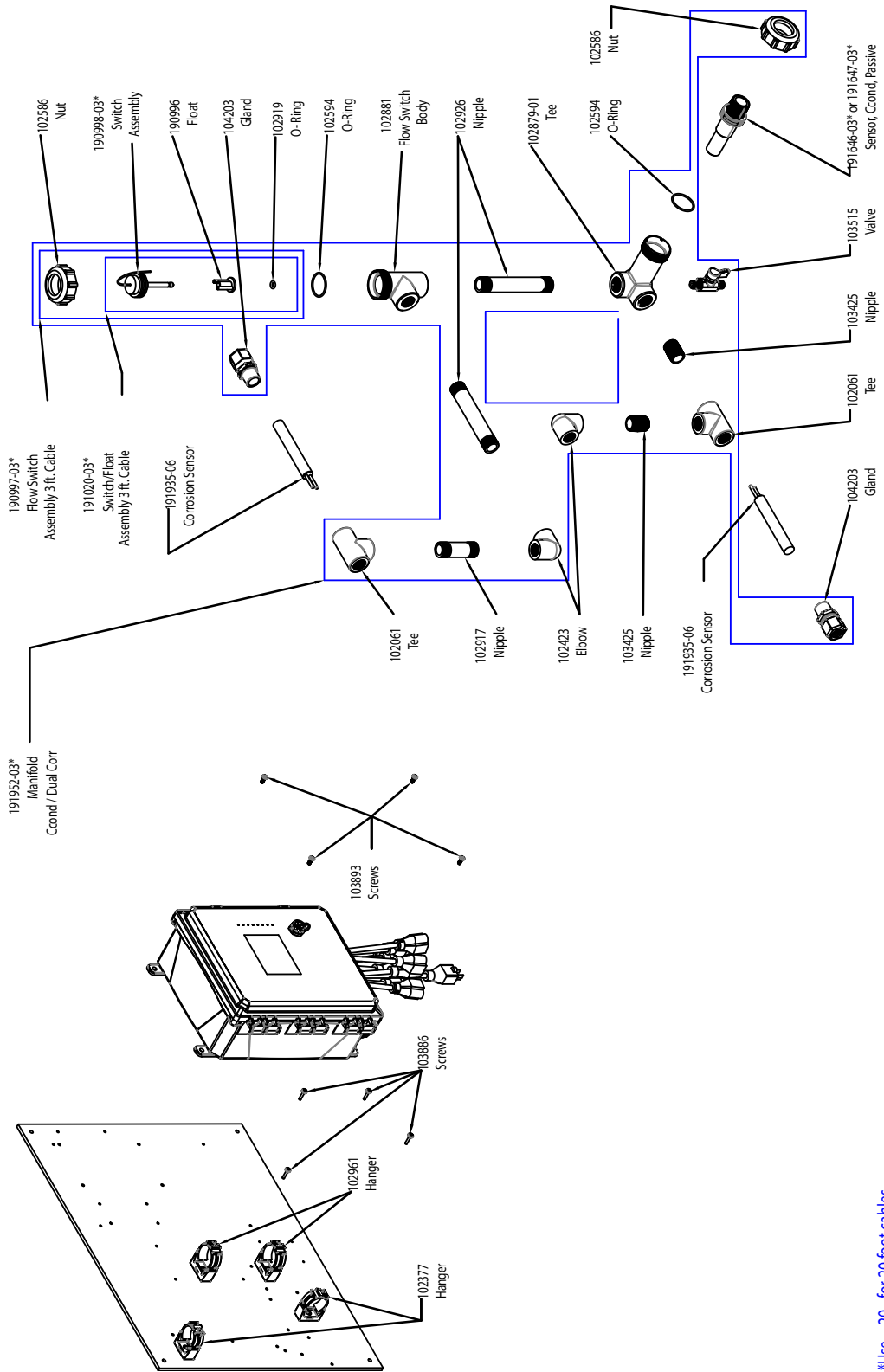
**PAOSNN:** Graphite contacting conductivity + Flow Switch manifold on panel + Disinfection (no sensor) + Corrosion



\*Use -20 for 20 foot cables

### SOCT900 Sensor Options PAPERNN, PBPRNN

**PAPERNN:** Graphite contacting conductivity + Dual Corrosion + Pyxis + Flow Switch manifold on panel  
**PBPRNN:** 316SS contacting conductivity + Dual Corrosion + Pyxis + Flow Switch manifold on panel

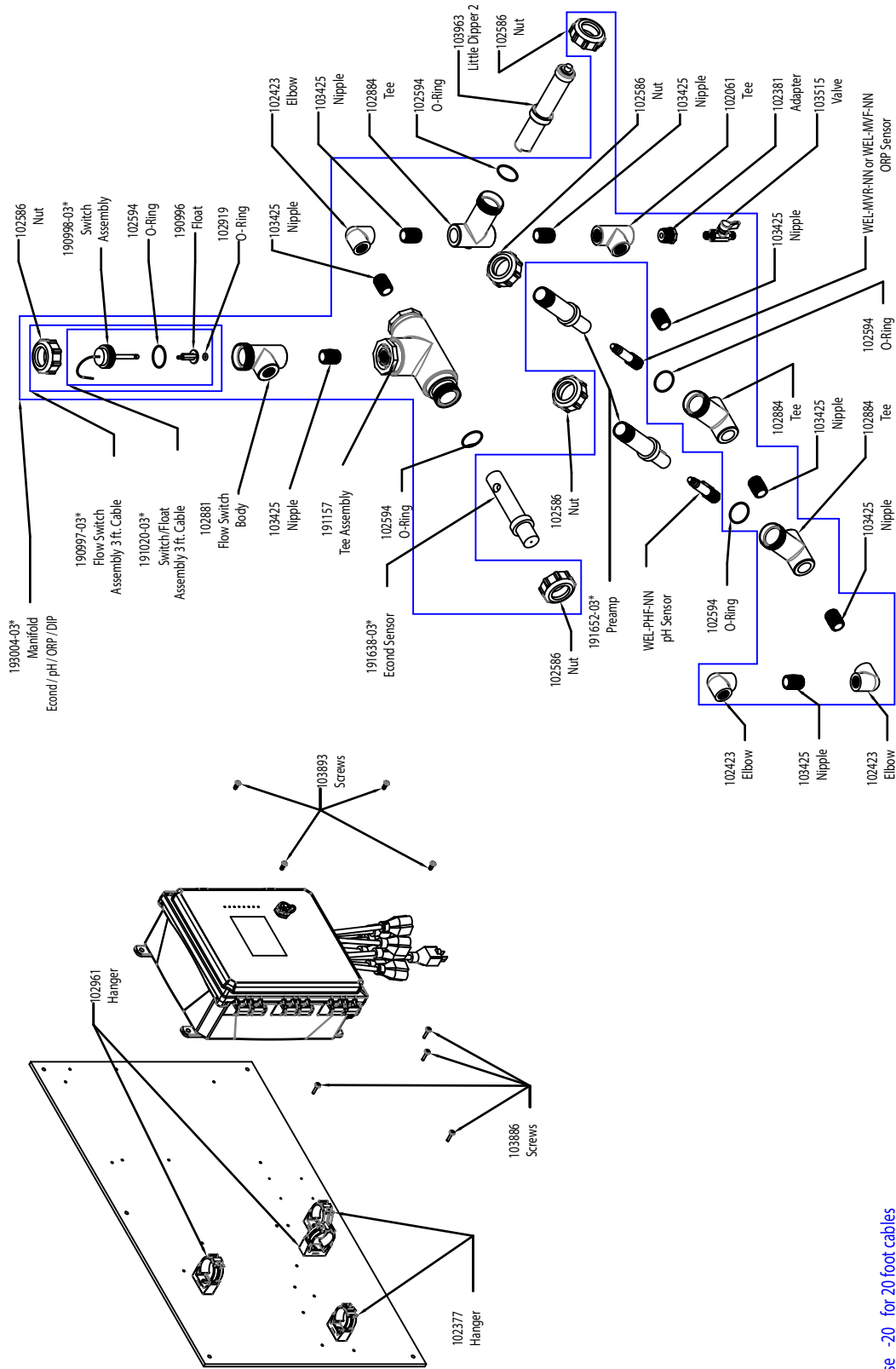


\*Use -20 for 20 foot cables

## SOCT900 Sensor Options PARNNN, PBRNNN

**PARNNN:** Graphite contacting conductivity + Dual Corrosion + Flow Switch manifold on panel

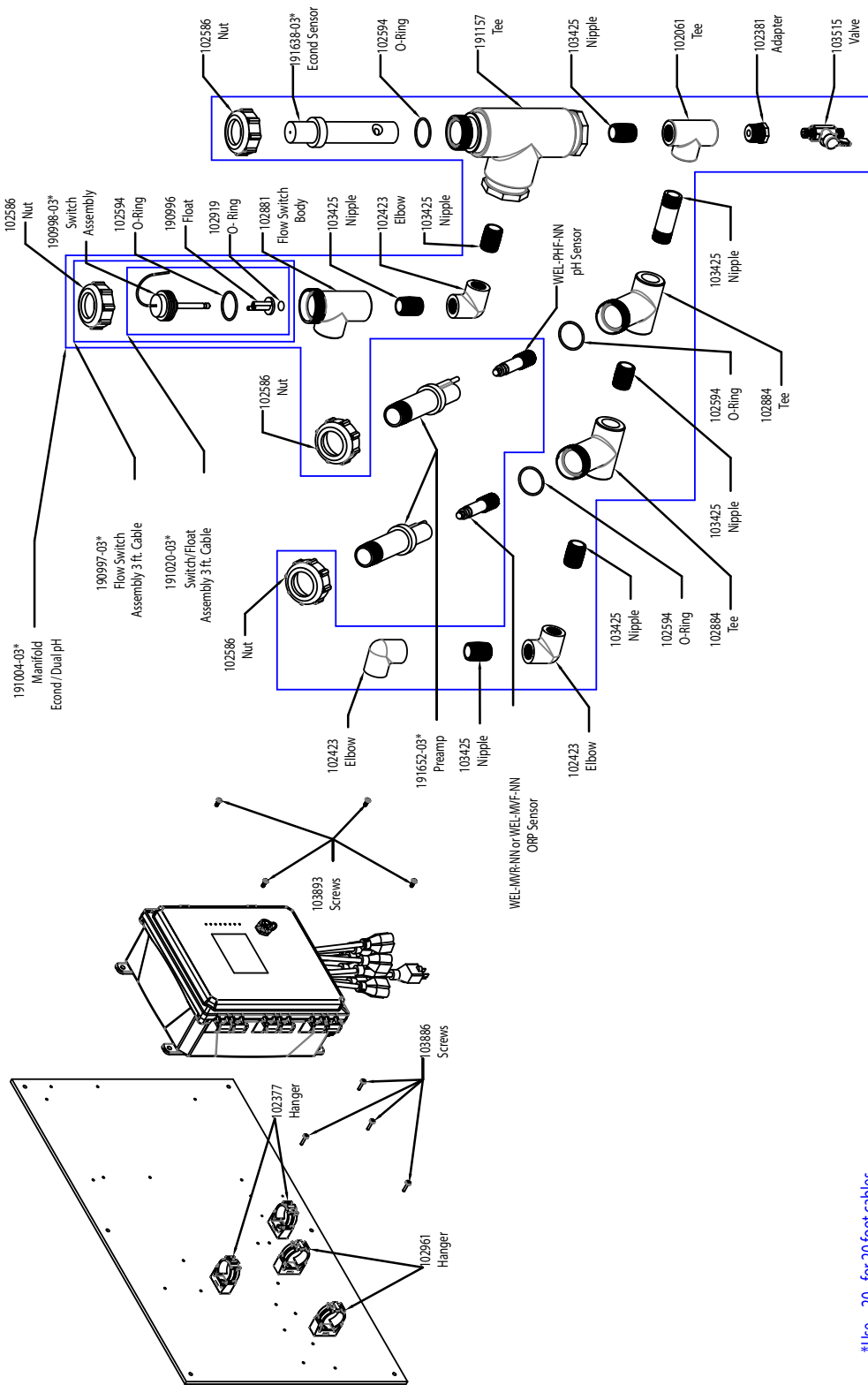
**PBRNNN:** 316SS contacting conductivity + Dual Corrosion + Flow Switch manifold on panel



\*Use -20 for 20 foot cables

## SOCT900 Sensor Options PCFHMN, PCFIMN

**PCFHMN:** Electrodeless conductivity + pH + LD2 + Flow Switch manifold on panel + Rod ORP  
**PCFIMN:** + Flat ORP



\*Use -20 for 20 foot cables

## SOCT900 Sensor Options PCFHNN, PCFINN

**PCFHNN:** Electrodeless conductivity + pH + Flow Switch manifold on panel + Rod ORP

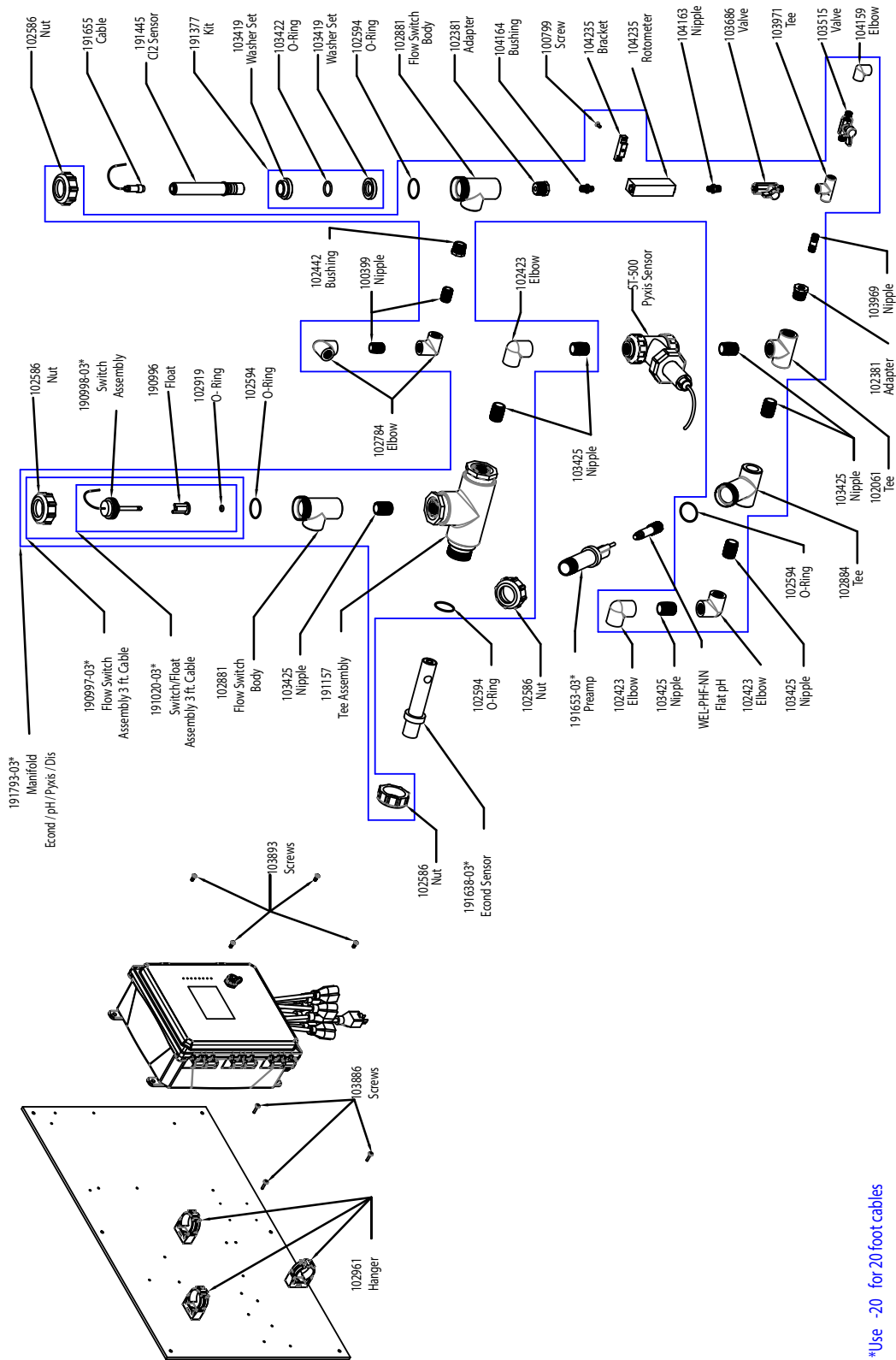
**PCFINN:** + Flat ORP











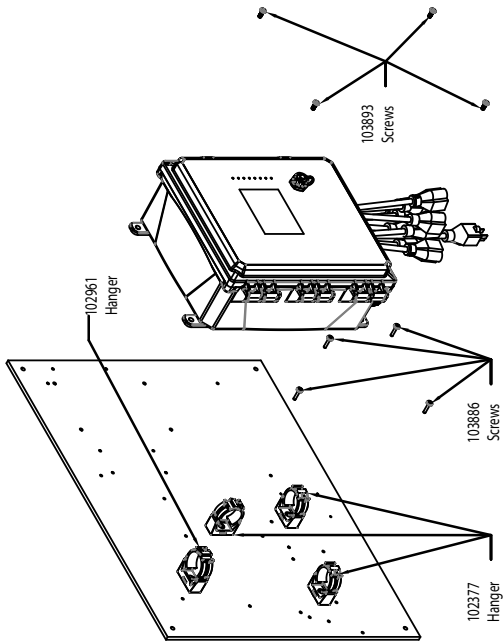
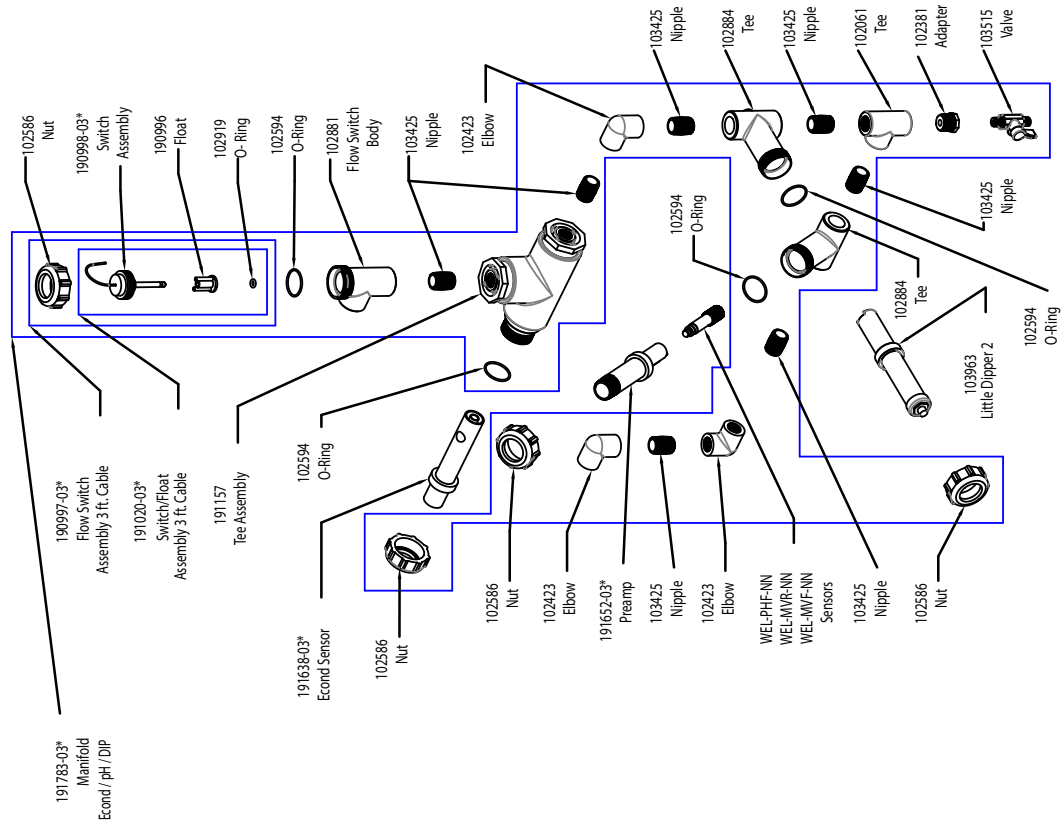
\*Use -20 for 20 foot cables

## SOCT900 Sensor Options PCFKPN, PCFLPN, PCFPSN

**PCFKPN:** Electrodeless conductivity + pH + Pyxis + Flow Switch manifold on panel + Chlorine

**PCFLPN:** + Chlorine Dioxide

**PCFPSN:** + Disinfection (no sensor)



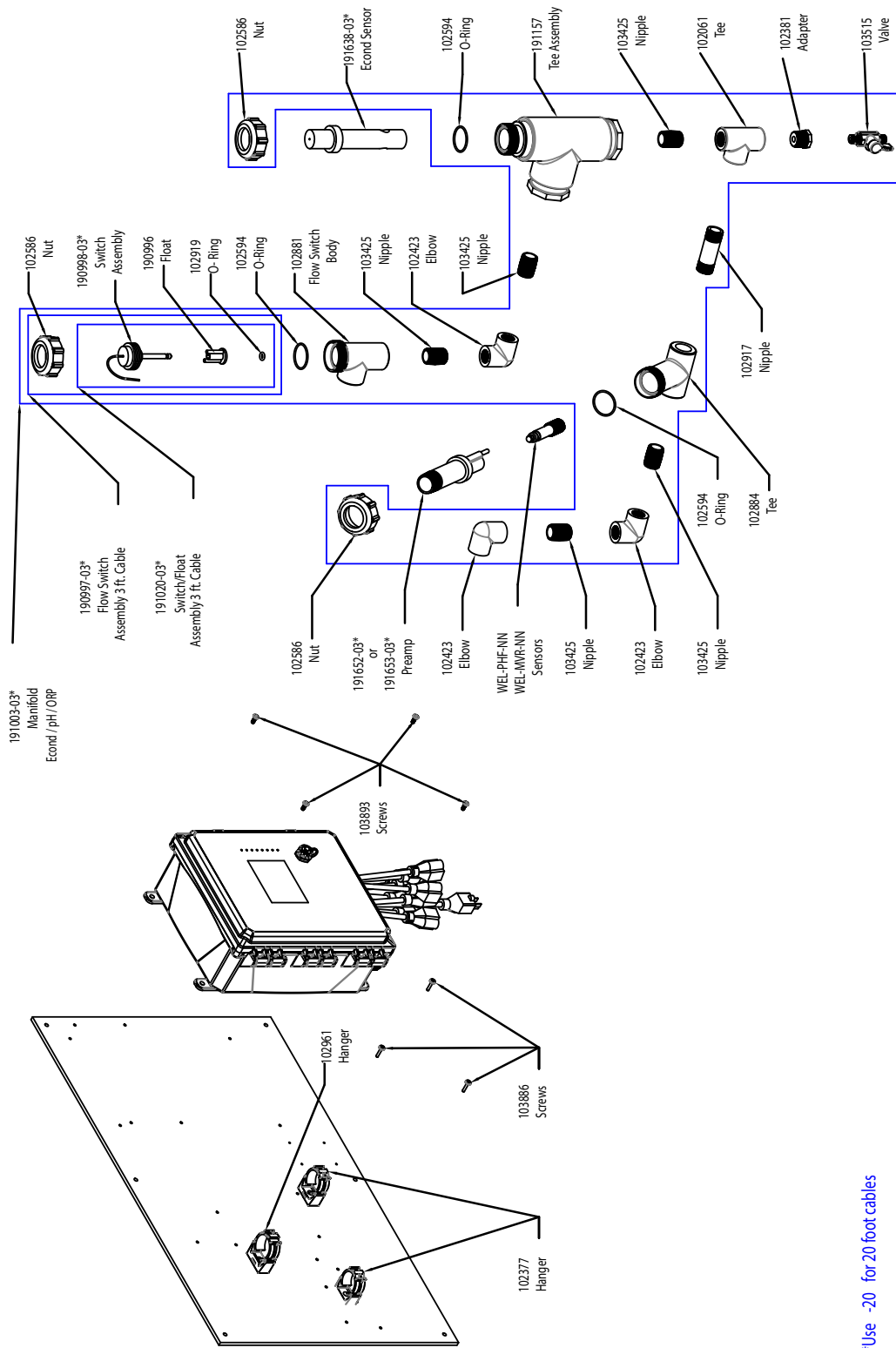
\*Use -20 for 20 foot cables

### SOCT900 Sensor Options PCFMNN, PCHMNN, PCIMNN

**PCFMNN:** Electrodeless conductivity + LD2 + Flow Switch manifold on panel + pH

**PCHMNN:** + Rod ORP

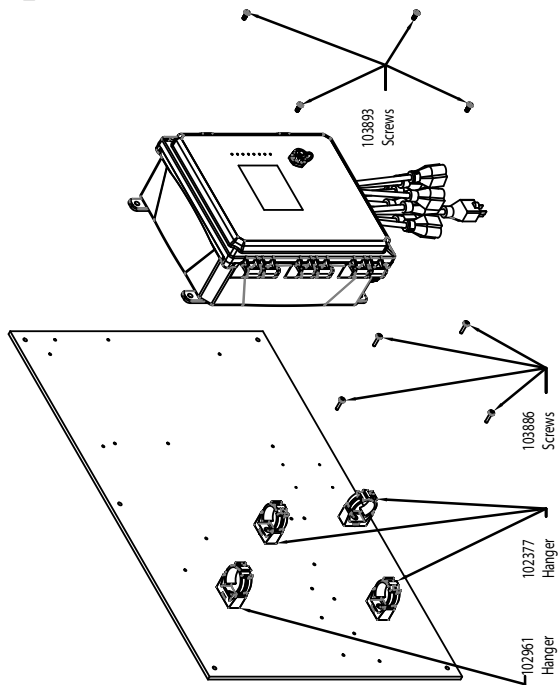
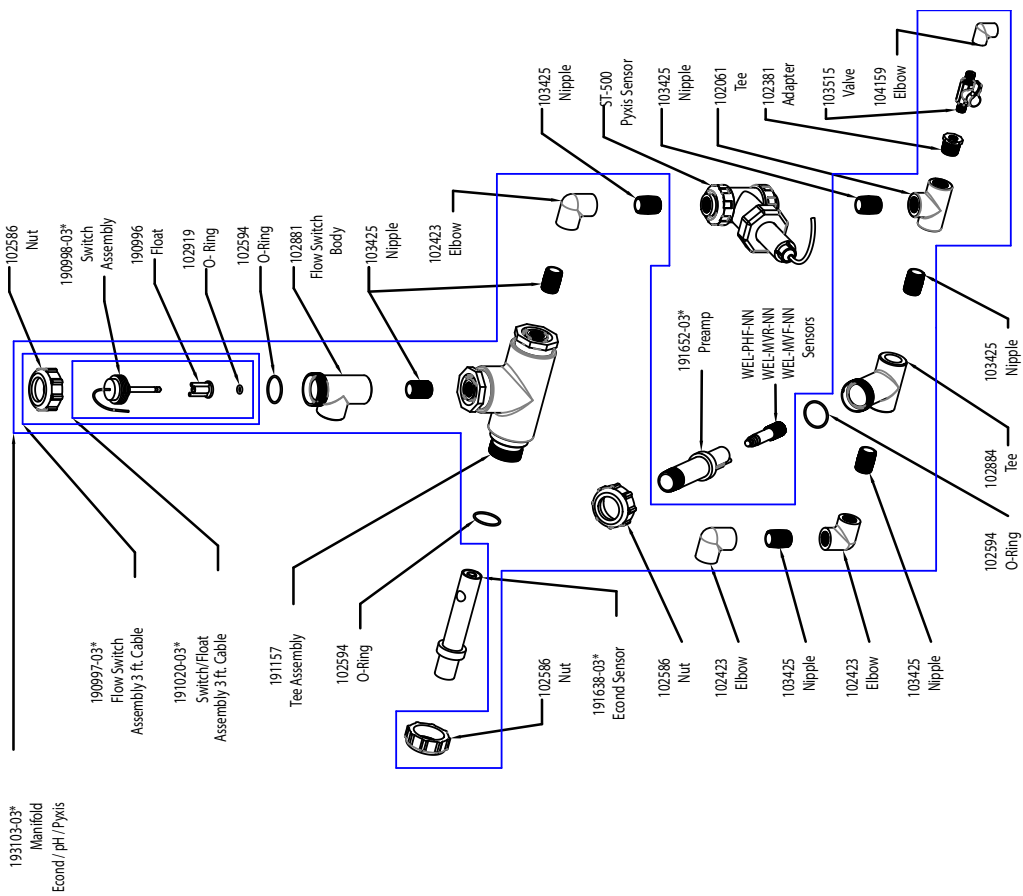
**PCIMNN:** + Flat ORP



\*Use -20 for 20 foot cables

**SOCT900 Sensor Options PCFNNN, PCHNNN, PCINNN, WIN900 Sensor Option PBENNN**

- PCFNNN:** Electrodeless conductivity + Flow Switch manifold on panel + pH
- PCHNNN:** + Rod ORP
- PCINNN:** + Flat ORP
- PBENNN:** Electrodeless conductivity + Flow Switch manifold on panel + pH with ATC



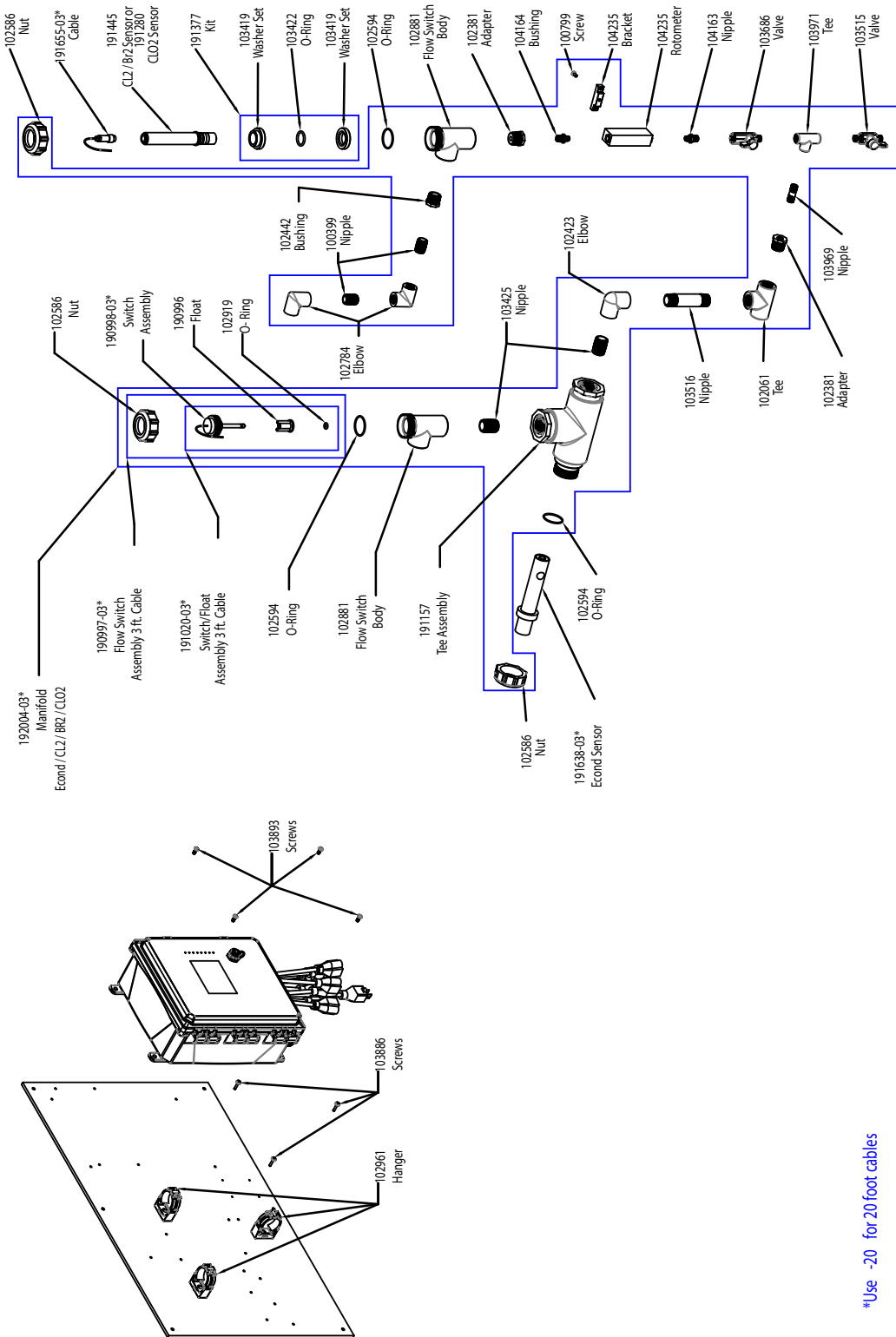
\*Use -20 for 20 foot cables

## SOCT900 Sensor Options PCFPNN, PCHPNN, PCIPNN

**PCFPNN:** Electrodeless conductivity + Pyxis + Flow Switch manifold on panel + pH

**PCHPNN:** + Rod ORP

**PCIPNN:** + Flat ORP

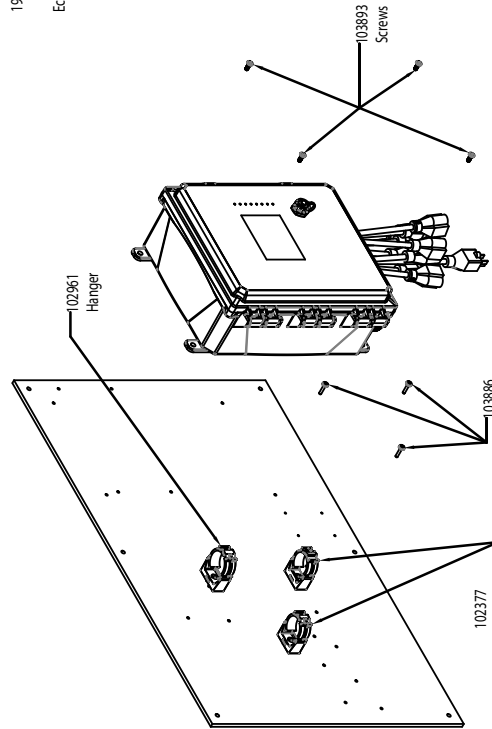
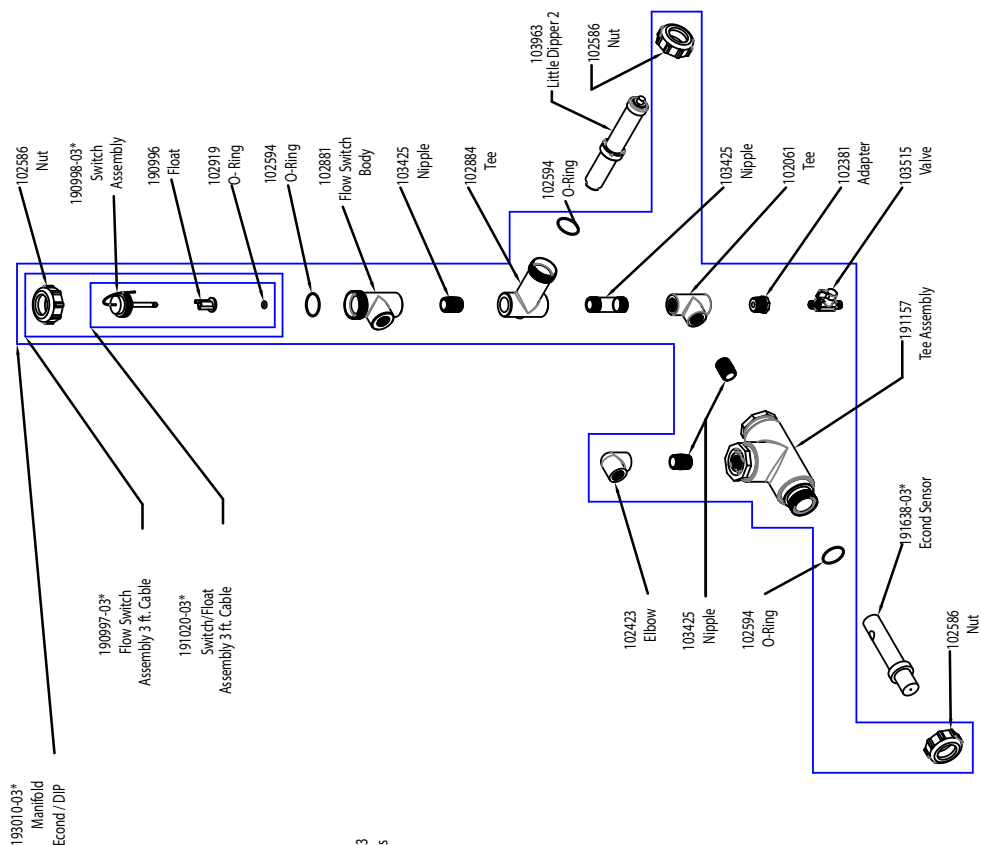


## SOCT90 Sensor Options PCKNNN, PCLNNN, PCSNNN

**PCKNNN:** Electrodeless conductivity + Flow Switch manifold on panel + Chlorine

**PCLNNN:** + Chlorine Dioxide

**PCSNNN:** + Disinfection (no sensor)

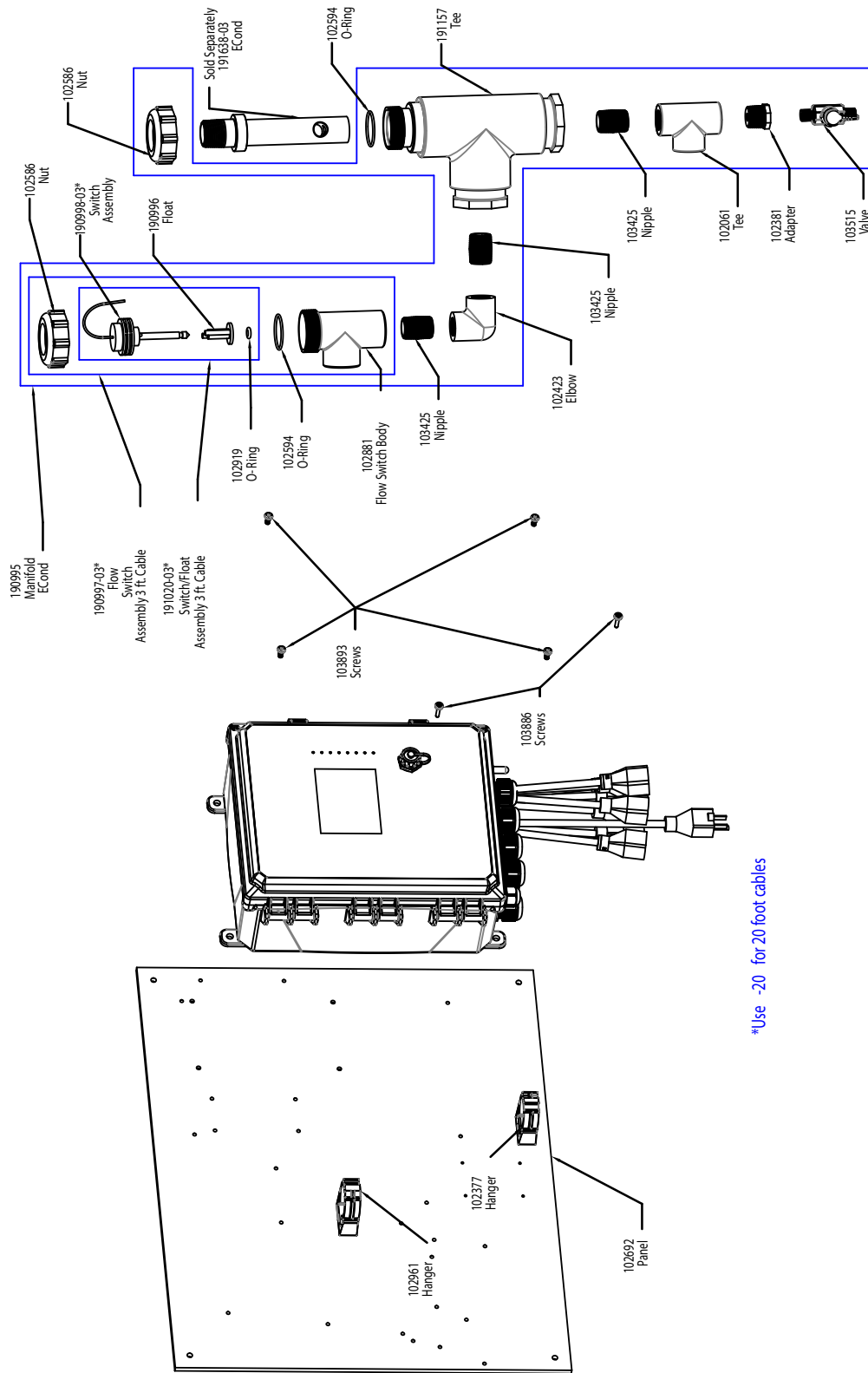


\*Use -20 for 20 foot cables

### SOCT900 Sensor Option PCMNNN

PCMNNN: Electrodeless conductivity + LD2 + Flow Switch manifold on panel

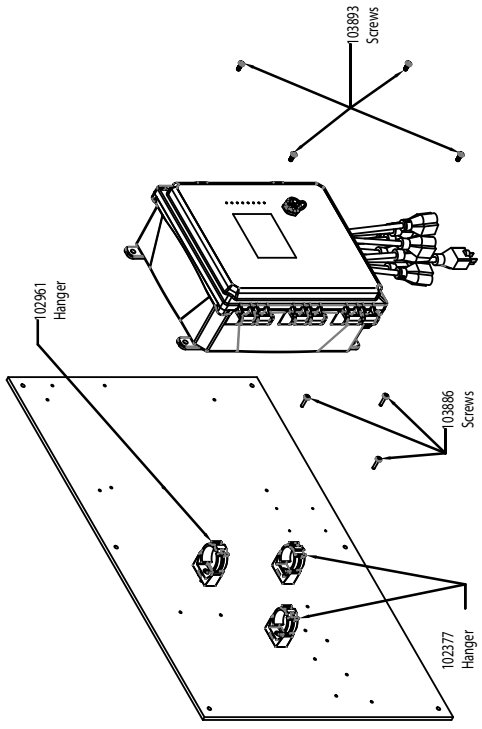
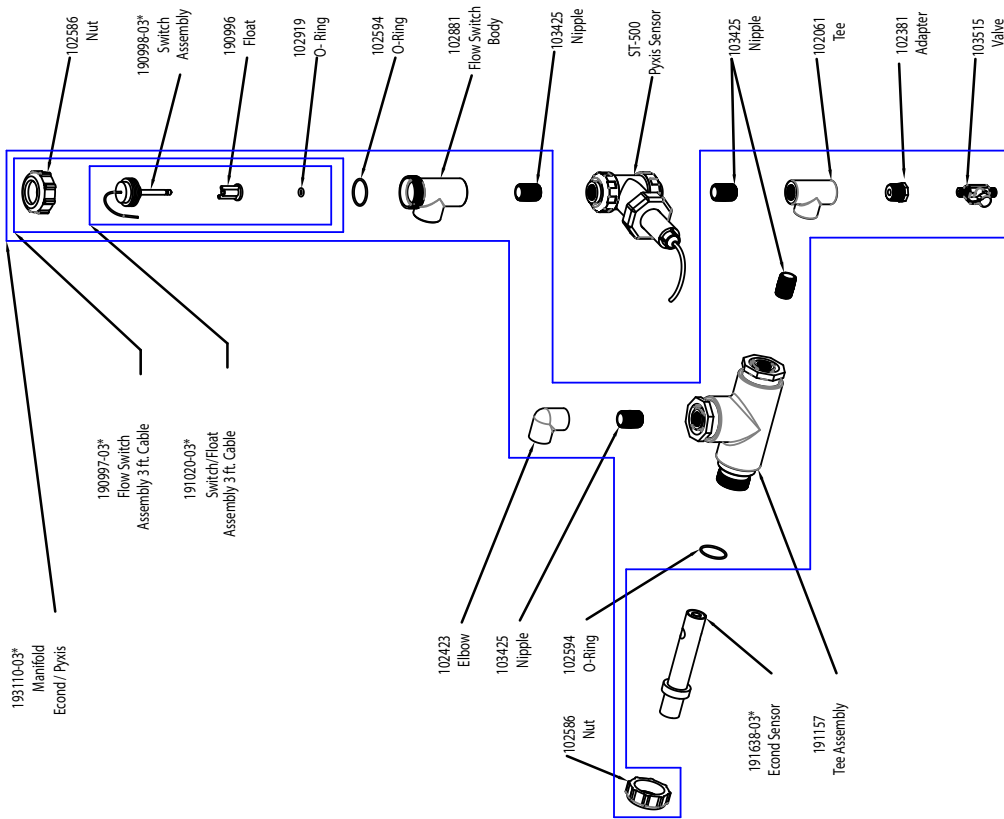




\*Use -20 for 20 foot cables

### SOCT900 Sensor Option PCNNNN

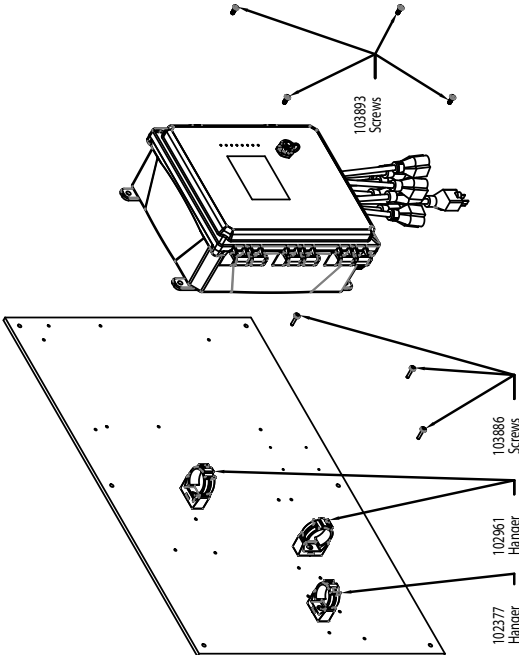
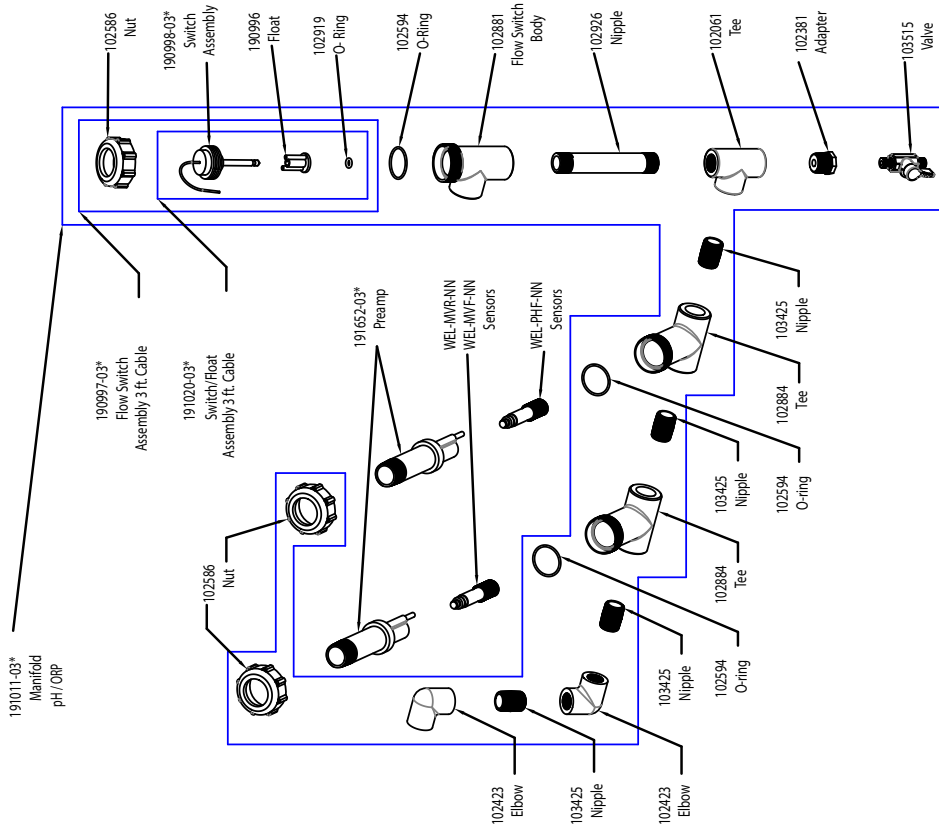
PCNNNN: CPVC electrodeless conductivity + Flow Switch manifold on panel



\*Use -20 for 20 foot cables

### SOCT900 Sensor Option PCPNNN

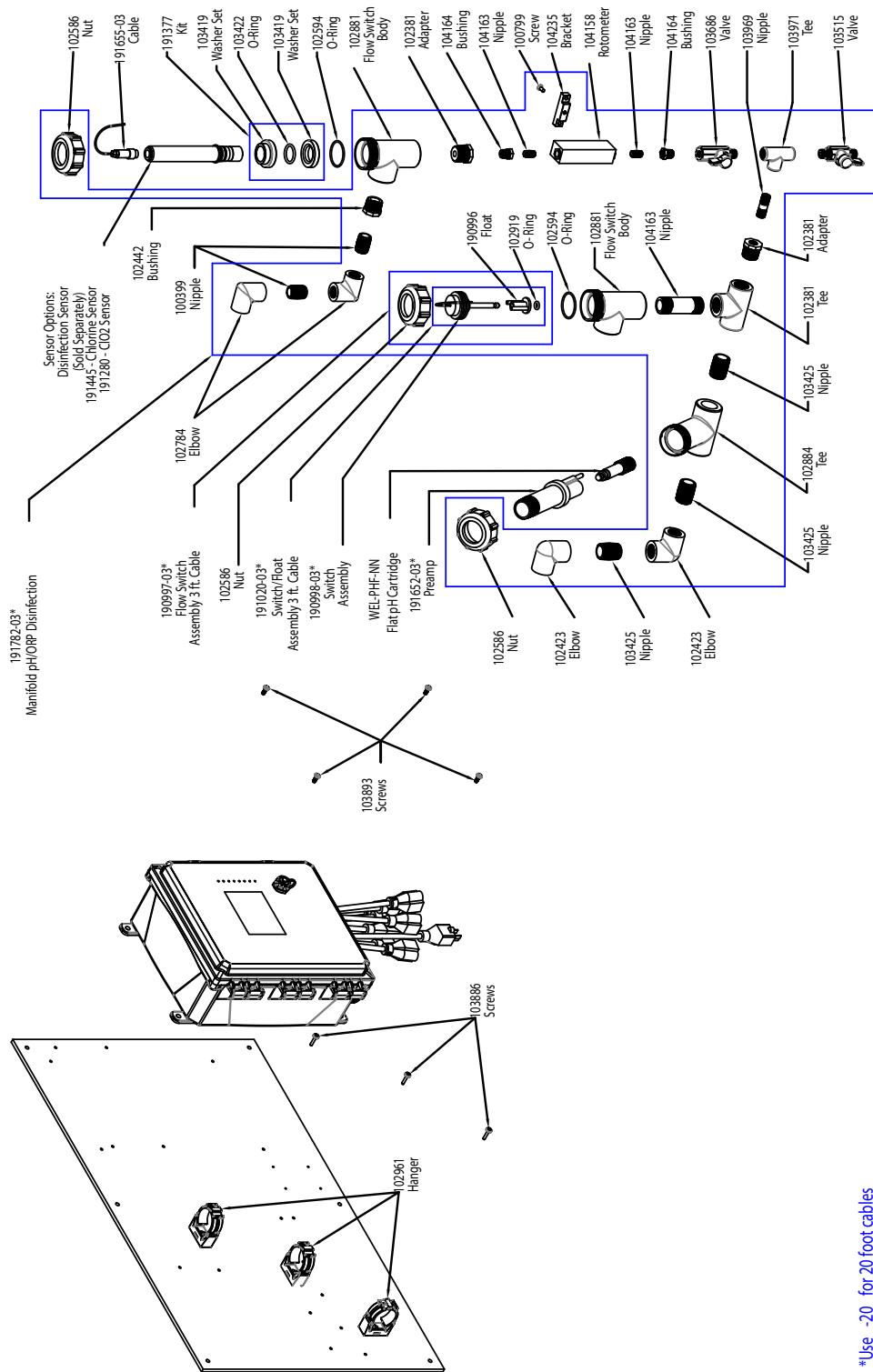
PCPNNN: Electrodeless conductivity + Pyxis + Flow Switch manifold on panel



\*Use -20 for 20 foot cables

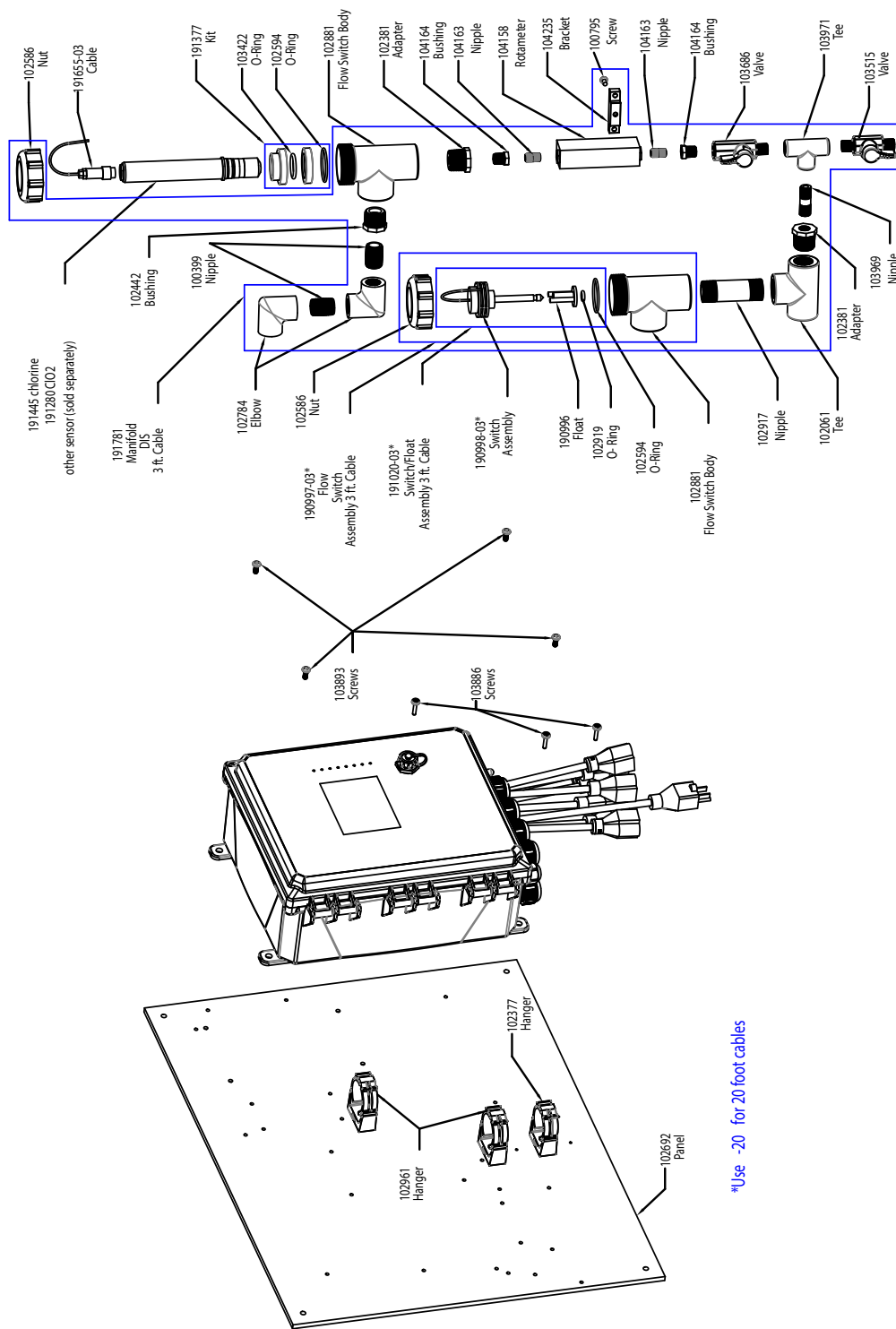
**SOCT900 Sensor Options PFHNNN, PFINNN**

**PFHNNN:** pH + Flow Switch manifold on panel + Rod ORP  
**PFINNN:** + Flat ORP



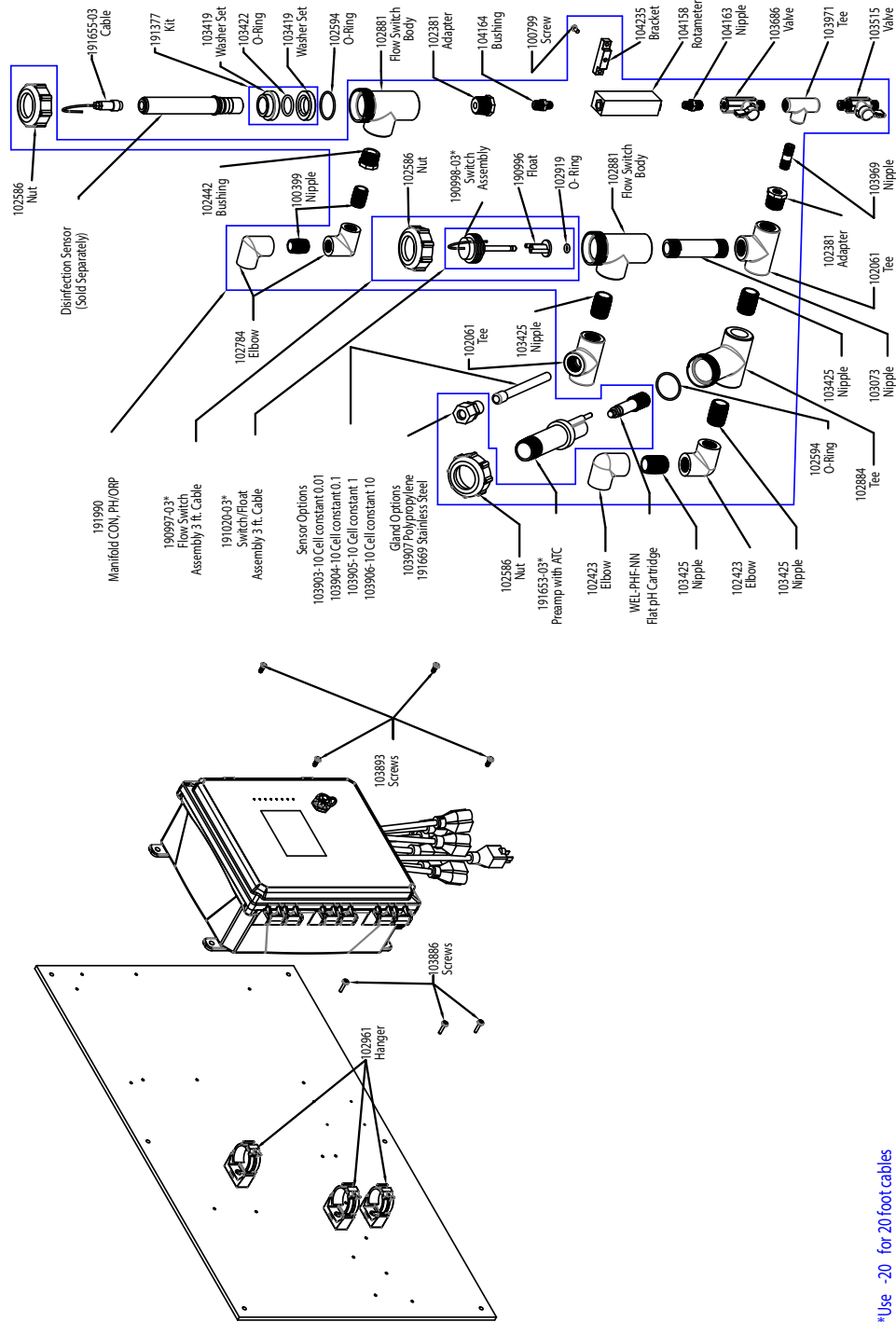
**SOCT900 Sensor Options PFKNNN, PFLNNN, PFSNNN**

- PFKNNN:** pH + Flow Switch manifold on panel + Chlorine
- PFLNNN:** + Chlorine Dioxide
- PFSNNN:** + Disinfection (no sensor)



**SOCT900 Sensor Options PKNNNN, PLNNNN. WIN900 Sensor Option PCNNNN**

- PKNNNN:** Extended pH Chlorine + Flow Switch manifold on panel
- PLNNNN:** Chlorine Dioxide + Flow Switch manifold on panel
- PCNNNN:** Disinfection (No Sensor) + Flow Switch manifold on panel



\*Use -20 for 20 foot cables

## SO900 Sensor Options PBCFNN, PBCGNN, PBCHNN, PBCINN, PBCJNN, PBCKNN, PBCLNN, PBCMNN

**PBCFNN:** Flat pH with ATC + Disinfection (No Sensor) + Flow Switch manifold on panel + Cell Constant 1.0 Low Pressure Generic conductivity

**PBCGNN:** + Cell Constant 0.1 Low Pressure Generic conductivity

**PBCHNN:** + Cell Constant 10 Low Pressure Generic conductivity

**PBCINN:** + Cell Constant 0.01 Low Pressure Generic conductivity

**PBCJNN:** + Cell Constant 1.0 High Pressure Generic conductivity

**PBCKNN:** + Cell Constant 0.1 High Pressure Generic conductivity

**PBCLNN:** + Cell Constant 10 High Pressure Generic conductivity

**PBCMNN:** + Cell Constant 0.01 High Pressure Generic conductivity

## **10.0 Service Policy**

---

Walchem controllers have a 2-year warranty on electronic components and a 1-year warranty on mechanical parts and electrodes. See Statement of Limited Warranty in front of manual for details.

Walchem controllers are supported by a worldwide network of authorized master distributors. Contact your authorized Walchem distributor for troubleshooting support, replacement parts, and service. If a controller is not functioning properly, circuit boards may be available for exchange after the problem has been isolated. Authorized distributors will provide a Return Material Authorization (RMA) number for any products being returned to the factory for repair. Repairs are generally completed in less than one week. Repairs that are returned to the factory by next-day-air freight will receive priority service. Out-of-warranty repairs are charged on a time and material basis.

**FIVE BOYNTON ROAD**  
TEL: 508-429-1110

**HOPPING BROOK PARK**

**HOLLISTON, MA 01746 USA**  
Web: [www.walchem.com](http://www.walchem.com)