



EH & EZ Series Electronic Metering Pump Instruction Manual

W A L C H E M

Five Boynton Road Hopping Brook Park Holliston, MA 01746 USA TEL 508-429-1110 FAX 508-429-7433

WEBSITE: www.walchem.com

Notice

© 2007 WALCHEM Corporation
Five Boynton Road, Holliston, MA 01746 USA
tel (508) 429-1110 fax (508) 429-7433
All Rights Reserved
Printed in USA

Proprietary Material

The information and descriptions contained herein are the property of WALCHEM Corporation. Such information and descriptions may not be copied or reproduced by any means, or disseminated or distributed without the express prior written permission of WALCHEM Corporation.

This document is for information purposes only and is subject to change without notice.

Statement of Limited Warranty

WALCHEM Corporation warrants equipment of its manufacture and bearing its identification to be free from defects in workmanship and material for a period of two years from date of delivery from the factory or authorized distributor under normal use and service and otherwise when such equipment is used in accordance with instructions furnished by WALCHEM Corporation and for the purposes disclosed in writing at the time purchased, if any. WALCHEM Corporation's liability under this warranty shall be limited to replacement or repair, F.O.B. Holliston, MA U.S.A. of any defective equipment or part which, having been returned to WALCHEM Corporation, transportation charges prepaid, has been inspected and determined by WALCHEM Corporation to be defective.

THIS WARRANTY IS IN LIEU OF ANY OTHER WARRANTY, EITHER EXPRESS OR IMPLIED, AS TO DESCRIPTION, QUALITY, MERCHANTABILITY, FITNESS FOR ANY PARTICULAR PURPOSE OR USE, OR ANY OTHER MATTER.

*P/N E00008.L
March 2007*

TABLE OF CONTENTS

Thank you for choosing a Walchem EH or EZ Series metering pump. This instruction manual deals with the correct installation, operation, maintenance and troubleshooting procedures for the EHB, EHC and EZ model metering pumps. Please read through it carefully to ensure the optimum performance, safety and service of your pump.

1.0	INTRODUCTION	1
1.1	Safety and Caution Notes	1
1.2	Principle of Operation	1
1.3	Model Code	2
1.4	Specifications	3
1.5	Dimensions	4
2.0	INSTALLATION	8
2.1	Unpacking	8
2.2	Location	8
2.3	Supply Tubing	10
2.4	Discharge Tubing	11
2.5	Installing Injection/BackPressure Valve	11
2.6	Electrical	12
3.0	OPERATION	13
3.1	Priming	13
3.2	Adjustment	13
3.3	Calibration	14
3.4	External Control	14
3.5	STOP Function	25
3.6	AC Power Interruption (Y-Control Module)	25
3.7	Auto Air Vent Valve Operation	26
3.8	MultiFunction Valve Operation	26
3.8	MultiFunction Valve Operation	27
4.0	MAINTENANCE	28
4.1	Diaphragm Replacement	28
4.2	Valve Replacement	28
4.3	Tubing	28
5.0	EXPLODED VIEW & PARTS GUIDE	29
6.0	TROUBLESHOOTING	41
7.0	SERVICE POLICY	42

1.0 INTRODUCTION

1.1 Safety and Caution Notes



Always wear protective clothing, eye protection and gloves before working on or near a metering pump. Follow all recommendations of the supplier of the solution being pumped. Refer to the MSDS from the solution supplier for additional precautions.

Walchem EH and EZ Series metering pumps should be installed where ambient temperatures do not exceed 122°F (50°C) or do not fall below 32°F (0°C), or where pump or tubing are directly exposed to sunlight.



WARNING Risk of electrical shock! This pump is supplied with a grounding conductor and grounding-type attachment plug. To reduce the risk of electrical shock, be certain that it is connected only to a properly grounded, grounding type receptacle with ratings conforming to the data on the pump data plate. Prior to performing any maintenance on a pump, disconnect the pump from the electrical power source.



Plumbing Precautions

All tubing must be securely attached to the fittings prior to starting the pump (see Section 2.3). Only use Walchem tubing with your pump. Tubing should be shielded to prevent possible injury in case of rupture or damage. UV resistant tubing should be used if the tubing is exposed to UV light. Always adhere to local plumbing codes and requirements. Be sure that the installation does not constitute a cross connection. Walchem is not responsible for improper installations. Prior to performing any maintenance on a pump, depressurize the discharge tubing.

If you are pumping downhill or into little or no system pressure, a back pressure/anti-siphon device must be installed to prevent over-pumping. Contact your Walchem distributor for additional information.



Solution Compatibility

CAUTION! This pump has been evaluated for use with water only. The suitability of this pump for use with liquids other than water (such as acid and alkaline) is the responsibility of the user. For liquids other than water, select the best-suited liquid end material combination using a chemical compatibility chart.

1.2 Principle of Operation

The EH and EZ series electronic metering pumps consist of a pump unit, a drive unit, and a control unit. The drive unit is an electromagnetic solenoid. When the solenoid coil is energized by the control unit the armature shaft moves forward due to the magnetic force of the solenoid. The shaft is attached to a PTFE faced diaphragm which is part of the pump unit. The diaphragm is forced into the pump head cavity decreasing volume and increasing pressure which forces liquid in the pump head out through the discharge check valves. When the solenoid coil is de-energized, a spring returns the armature to its starting position. This action pulls the diaphragm out of the head cavity increasing volume and decreasing pressure. Atmospheric pressure then pushes liquid from the supply tank through the suction check valves to refill the pump head.

1.3 Model Code

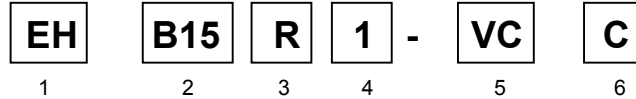

1 Pump Series

EH Electronic metering pump with external pulse control or manual speed control (adjustable to 360 strokes per minute) and manually adjustable stroke length. (Typical turndown ratio 125:1.)

EZ Electronic metering pump with manual speed control (adjustable to 360 strokes per minute)

2 Capacity/Pressure Rating (See Section 1.4 for detailed chart.)

3 Control Module

D For use on all EZ models, features digitally adjustable speed and fixed stroke length

R For use on all EHB & EHC models, features external pulse control.

Y For use on all EHB & EHC models, features analog and external pulse control with pulse divide and multiply capability.

4 Voltage

1 115 VAC, 50/60 Hz

2 230 VAC, 50/60 Hz

5 Liquid End (See Section 1.4 for detailed chart.)

6 Options

C High Compression Head: Supplied standard with auto air vent valve in place of manual air vent valve. Available for EHB10, EHB15, EHC15 and EHC20 sizes with -VC liquid ends only.

M Multifunction Valve is supplied in place of the manual air vent valve. Available for the EZ and EHB/C 10-20 sized pumps with VC, VE, VF, PC, PE, PCH and PEH liquid ends. Not available with the AAVV feature.

A Auto Air Vent Valve supplied in place of manual air vent valve. Available for EZ and EH Series in B10, B15, C15 and C20 sizes with – VC liquid ends only.

H High Pressure Head available only for PC/PE liquid ends. Available for EHB10 and EHC15 sizes only. Rated @ 215 PSI.

1.4 Specifications

Electrical	50/60 Hz, single phase			
	EHB/EZB	115 VAC±10%	0.9 Amp max.	16 watt avg.
		230 VAC±10%	0.4 Amp max.	16 watt avg.
EHC/EZC	115 VAC±10%	1.4 Amp max.	24 watt avg.	
	230 VAC±10%	0.6 Amp max.	24 watt avg.	

Operating Conditions

Ambient temperature	32°F to 122°F (0°C to 50°C)
Relative humidity	30% to 90% non-condensing
Liquid temperature	32° to 104°F (0 to 40°C) for PVC based liquid ends 32° to 140°F (0 to 60°C) for PP, PVDF, SS based liquid ends

Capacity/Pressure Rating

Size	Maximum Output Capacity		Output per Stroke (mL)		Maximum Pressure ³		Connection Size (in) Tubing O.D. ²
	(Gal/hr)	(mL/min)	Min.	Max.	PSI	MPa	
B10¹	0.6	38	0.05	0.11	150	1.0	3/8
B10(H)	0.5	30	0.04	0.08	215	1.5	3/8
B15¹	1.0	65	0.09	0.18	105	0.7	3/8
B20¹	1.5	95	0.13	0.26	60	0.4	3/8
B30¹	3.2	200	0.28	0.56	30	0.2	1/2
C15	1.3	80	0.09	0.22	150	1.0	3/8
C15(H)	0.8	50	0.06	0.14	215	1.5	3/8
C20	2.0	130	0.14	0.36	105	0.7	3/8
C30	4.3	270	0.30	0.75	50	0.35	1/2
C35⁴	6.7 ⁴	420 ⁴	0.46	1.17	30	0.2	1/2

¹ Available sizes for EZ pumps

² 1/4" NPT female for 316 SS

³ Auto Air vent valve reduces maximum pressure approx. 35 PSI (0.2 MPa)

⁴ EZC35 rated output is 6.3 GPH (400 ml/min)

Adjustment Range

Stroke length adjustment range	40% to 100% (EHB and EHC only)
Frequency adjustment range	0 to 360 strokes per minute

Materials of Construction

Liquid End Code	Pump Head & Fittings	Diaphragm	Valve Balls	Valve Seat	Valve Seals	Gasket	Tubing
PC	GFRPP	PTFE (bonded to EPDM)	CE	FKM	FKM	PTFE	PE
PE	GFRPP		CE	EPDM	EPDM		
VC	PVC		CE	FKM	FKM		
VE	PVC		CE	EPDM	EPDM		
VF	PVC		PTFE	EPDM	EPDM		
TC	PVDF		CE	FKM	FKM		
FC	PVDF		CE	PCTFE	PTFE		
SH	SS		HC	HC	PTFE		

CE Alumina ceramic

EPDM Ethylene propylene diene monomer

FKM Fluoroelastomer

GFRPP Glass fiber reinforced polypropylene

HC Hastelloy C276

PCTFE Polychlorotrifluoroethylene

PE Polyethylene

PTFE Polytetrafluoroethylene

PVC Polyvinylchloride (translucent)

PVDF Polyvinylidene fluoride

SS 316 stainless steel

1.5 Dimensions

EH Models with thermoplastic liquid ends and air vent valves

EHB Model shown for reference

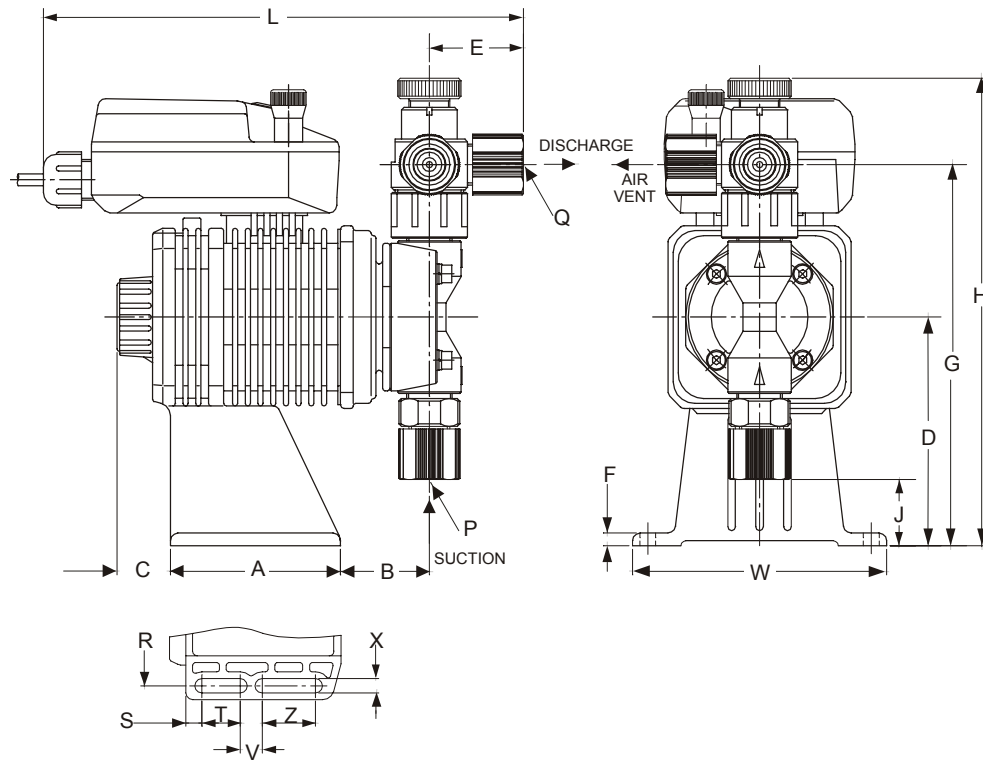

Model				A	B	C	D	E	F	G	H	J	L	P&Q TUBING G	W	
EHB	10 15 20	R1 R2	-PC	2.64	1.42	0.83	3.54	1.46	0.20	5.91 [6.13] ³	7.24	1.02	7.48	3/8 OD 1/4 ID	3.94	
			-PE					(3.01) ¹			{7.56} ²		(9.07) ¹			
			-VC					[1.83] ³			[8.40] ³		{7.72} ²			
EHB	30	R1 R2	-VE	2.64	1.57	0.83	3.54	0.87	0.20	8.04	8.04	0.31	7.05	1/2 OD 1/4 ID	3.94	
			-VF										(7.41) ²			
EHC	15 20	R1 R2	-PC	3.82	1.26	0.67	3.94	1.46	0.20	6.30 [6.44] ³	7.64	1.42	8.35	3/8 OD 1/4 ID	4.57	
			-PE					(3.01) ¹			{7.95} ²		(9.90) ¹			
			-VC					[1.83] ³			[8.75] ³		{8.58} ²			
EHC	30 35	R1 R2	-VE	3.82	1.42	0.67	3.94	0.87	0.20	8.44	8.44	0.71	7.92	1/2 OD 3/8 ID	4.57	
			-VF										(8.29) ²			
			-TC													

¹ With Auto Air Vent Valve

² With Y-Control Module

³ With Multifunction Valve

Mounting Dimensions	R	S	T	V	Z	X
EHB all variations	3.46	0.28	0.65	0.37	0.91	0.24
EHC all variations	3.94	0.28	0.67	0.39	1.81	0.24

All dimensions in inches

EH-FC Models without an air vent valve
 EHB Model Shown for reference

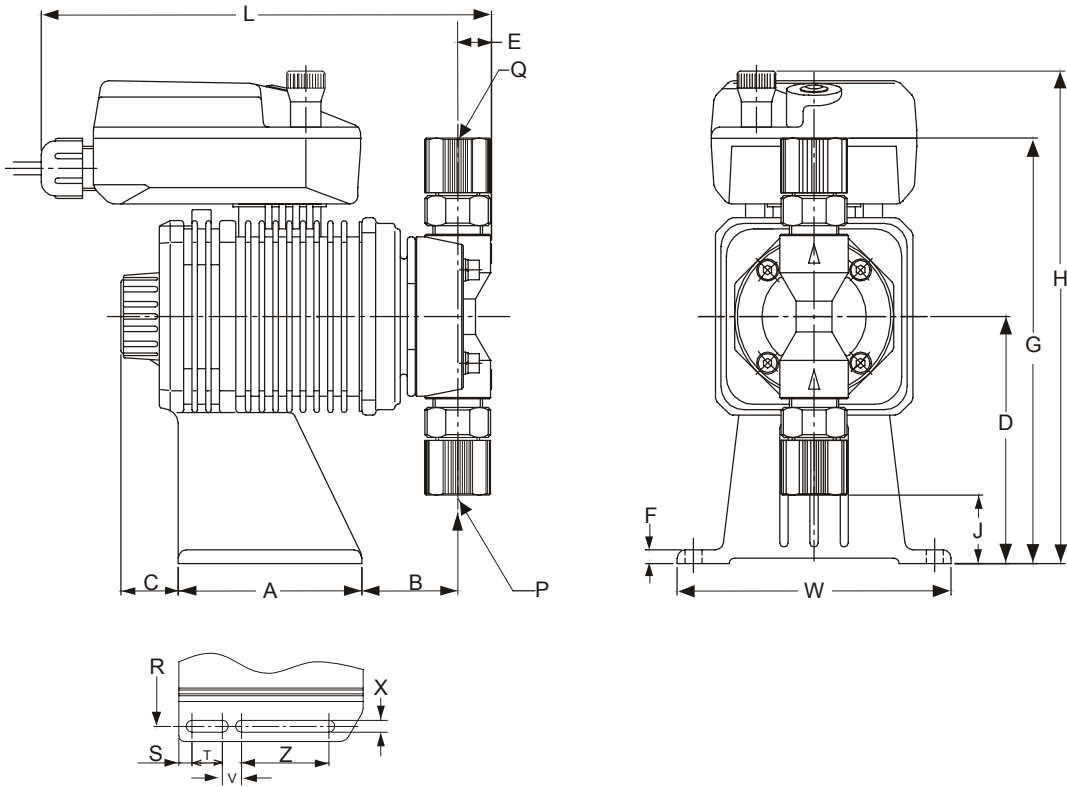

Model				A	B	C	D	E	F	G	H	J	L	P&Q TUBING	W
EHB	10 20	R1 R2	-FC	2.64	1.38	0.83	3.54	0.47	0.20	6.04	7.07 (7.56) [‡]	1.04	6.46 (6.81) [‡]	3/8 OD 1/4 ID	3.94
EHB	30	R1 R2	-FC	2.64	1.57	0.83	3.54	0.63	0.20	6.77	7.07 (7.56) [‡]	0.31	6.81 (7.17) [‡]	1/2 OD 3/8 ID	3.94
EHC	15 20	R1 R2	-FC	3.82	1.22	0.67	3.94	0.47	0.20	6.46	7.46 (7.95) [‡]	1.42	7.36 (7.75) [‡]	3/8 OD 1/4 ID	4.57
EHC	30 35	R1 R2	-FC	3.82	1.42	0.67	3.94	0.63	0.20	7.17	7.46 (7.95) [‡]	0.71	7.68 (8.05) [‡]	1/2 OD 3/8 ID	4.57

[‡] With Y-Control Module

Mounting Dimensions	R	S	T	V	Z	X
EHB all variations	3.46	0.28	0.65	0.37	0.91	0.24
EHC all variations	3.94	0.28	0.67	0.39	1.81	0.24

All dimensions in inches

EH Models with stainless steel liquid end materials

EHB Model Shown for reference

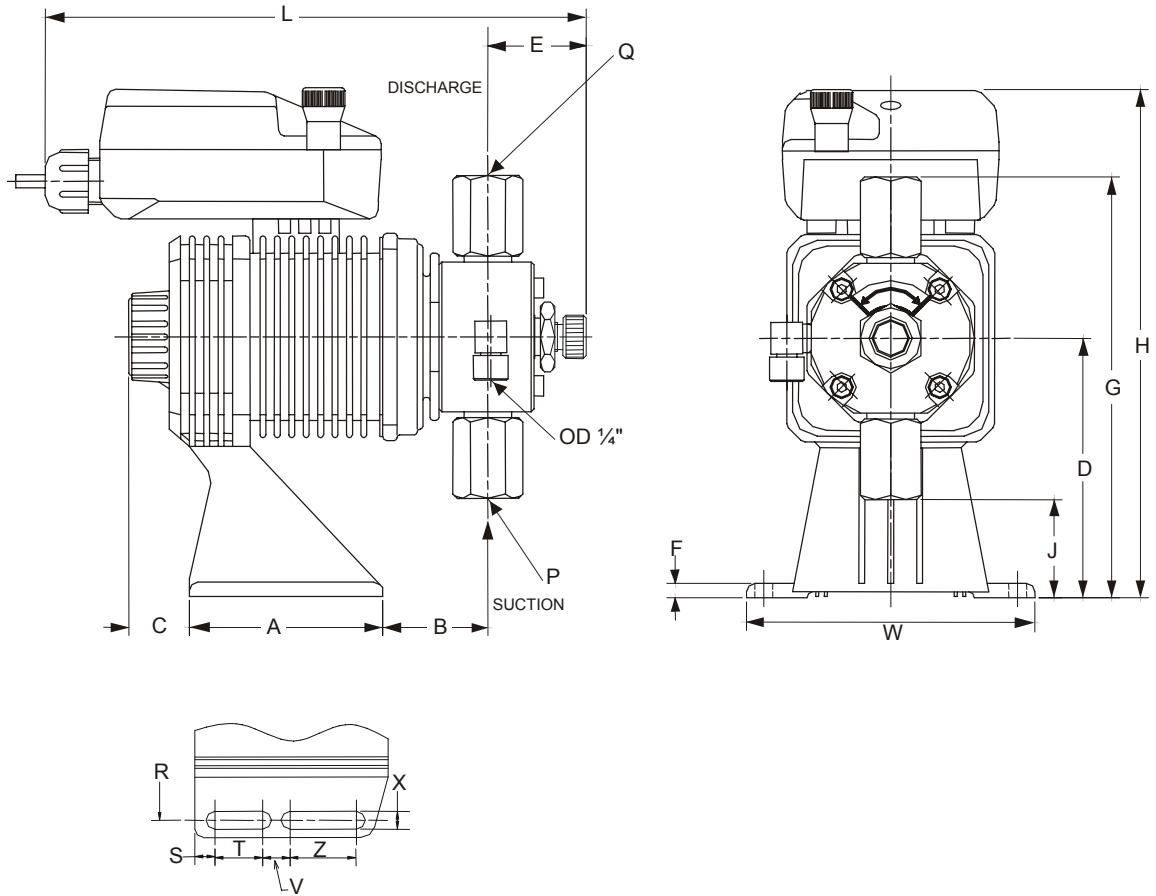

Model				A	B	C	D	E	F	G	H	J	L	P&Q TUBING	W
EHB	10 20	R1	-SH	2.64	1.38	0.83	3.54	1.34	0.20	5.75	7.07	1.34	7.38	1/4" NPTF	3.94
		(7.56) [‡]									(7.74) [‡]				
EHC	20	R1 R2	-SH	3.82	1.22	0.67	3.94	1.34	0.20	6.14	7.46 (7.95) [‡]	1.73	8.29 (8.66) [‡]	1/4" NPTF	4.57
EHC	30	R1 R2	-SH	3.82	1.38	0.67	3.94	1.30	0.20	6.53	7.46 (7.95) [‡]	1.34	8.29 (8.66) [‡]	1/4" NPTF	4.57
	35									6.50		1.22			

[‡] With Y-Control Module

Mounting Dimensions	R	S	T	V	Z	X
EHB all variations	3.46	0.28	0.65	0.37	0.91	0.24
EHC all variations	3.94	0.28	0.67	0.39	1.81	0.24

All dimensions in inches

EZ Models with thermoplastic liquid end materials

EZB Model Shown for reference

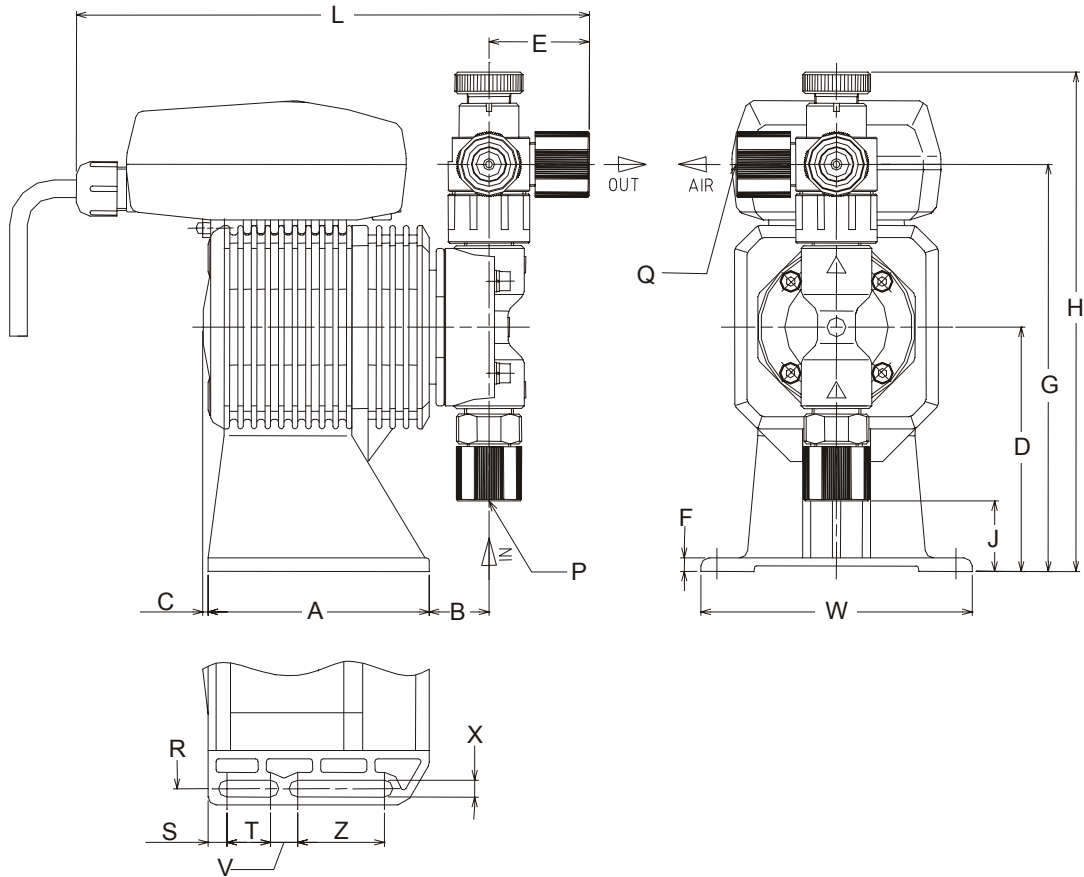

All dimensions in inches

Model			A	B	C	D	E	F	G	H	J	L	P & Q TUBING	W	
EZB	10 15 20	D1	-VC -VE	3.21	0.87	0.08	3.54	1.46	0.20	5.91 [6.11] ²	7.24 [8.39] ²	1.02	7.44 (9.53) ¹ [7.81] ²	3/8" O.D.	3.94
			-PC -PE					(3.03) ¹							
			-TC -VF					[1.83] ²							
	30	D2	-FC	3.21	0.87	0.08	3.54	0.51	0.20	6.09	6.83	1.00	6.50	3/8" O.D.	3.94
			-VC -VE	3.21	1.02	0.08	3.54	0.87	0.20	6.75	8.00	0.32	7.01	1/2" O.D.	3.94
			-PC -PE	3.21	1.02	0.08	3.54	0.87	0.20	6.75	8.00	0.32	7.01	1/2" O.D.	3.94
			-TC -VF	3.21	1.02	0.08	3.54	0.63	0.20	6.85	6.85	0.24	6.77	1/2" O.D.	3.94
EZC	15 20	D1	-VC -VE	4.13	0.94	---	3.94	1.46	0.31	6.30 [6.50] ²	7.64 [8.79] ²	1.42	8.15 (10.24) ¹ [8.52] ²	3/8" O.D.	4.57
			-PC -PE					(3.03) ¹							
			-TC -VF					[1.83] ²							
	30 35	D2	-FC	4.13	0.94	---	3.94	0.51	0.31	6.48	7.44	1.39	7.20	3/8" O.D.	4.57
			-VC -VE	4.13	1.10	---	3.94	0.87	0.31	7.11	8.37	0.71	7.72	1/2" O.D.	4.57
			-PC -PE	4.13	1.10	---	3.94	0.87	0.31	7.11	8.37	0.71	7.72	1/2" O.D.	4.57
			-TC -VF	4.13	1.10	---	3.94	0.63	0.31	7.44	7.44	0.63	7.48	1/2" O.D.	4.57

¹ Dimension with automatic air vent valve option

² With Multifunction valve

Mounting Dimensions	R	S	T	X	V	Z
EZB all variations	3.46	0.28	0.63	0.24	0.39	1.26
EZC all variations	3.94	0.59	1.18	0.28	0.59	1.18

2.0 INSTALLATION

2.1 Unpacking

Open the shipping carton and inspect contents for damage. If any items are missing or damaged contact your local distributor.



Pumps are pre-primed with water at the factory. If the application is not compatible with water, drain and dry before use. Be sure to remove caps from fittings before attaching tubing.

CAUTION: Head bolts may have loosened during storage or shipment. Be sure to check and tighten to 19 lb-in torque, if necessary.

Do not handle or move the pumps using the Control Module only. The pump should be supported by the base or drive unit during handling

2.2 Location

Choose a location for the pump which is clean, dry, close to an electrical outlet, and allows convenient access to stroke length control, frequency control, and tubing connections. Avoid areas where ambient temperature exceeds 122°F (50°C) or falls below 32°F (0°C), or where the pump or tubing would be exposed to direct sunlight.

This pump is cord connected and not intended for permanent mounting to a building structure. However, temporary mounting to stabilize the pump during operation may be necessary as long as tools are not required for the installation or removal of the pump.

Flooded suction (mounting the pump below the level of liquid in the supply tank) is strongly recommended, especially when pumping liquids that readily generate gas bubbles. Sodium hypochlorite and hydrogen peroxide are common examples of such liquids. (See Figure 1.)

If flooded suction mounting is not possible, a shelf adjacent to (but not directly above) the supply tank often works well. (See Figure 2.) The supply tank or cover can also be used if it has provisions for mounting a pump. (See Figure 3.) In any case, the total suction lift should not exceed 5 ft (1.5m).

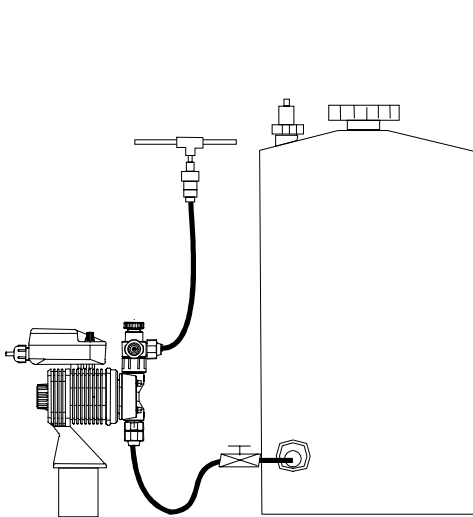

Figure 1
Flooded Suction

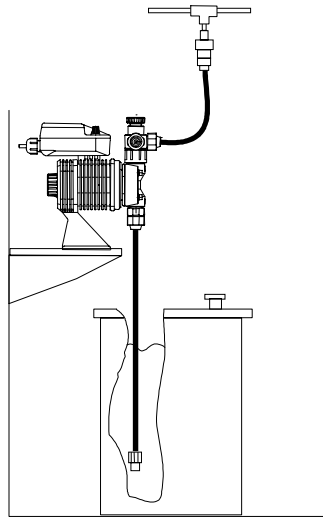

Figure 2
Shelf Mount

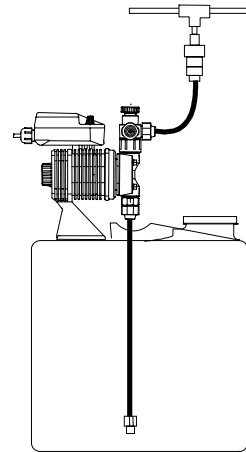

Figure 3
Tank Mount

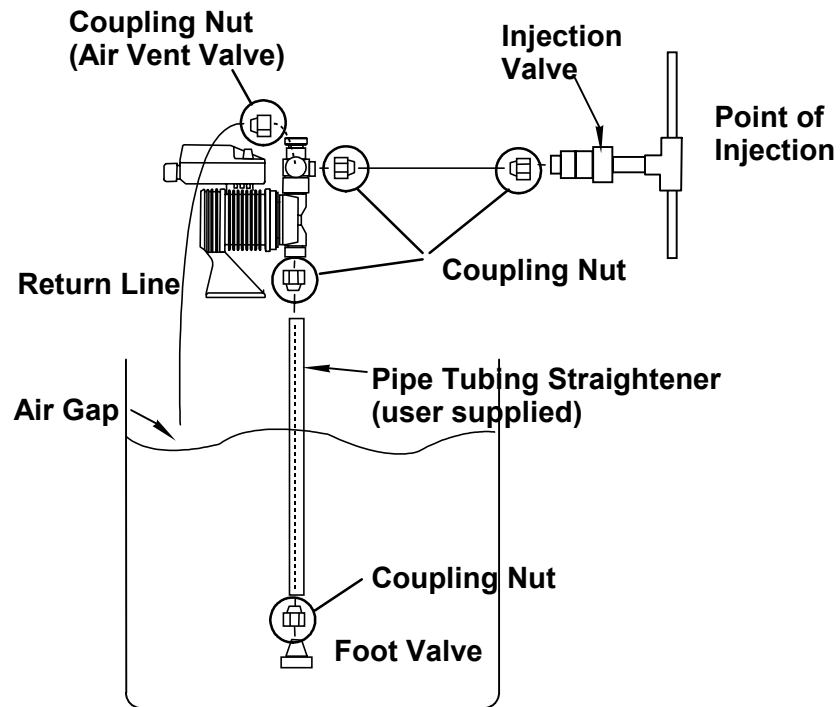

Figure 4 Connecting Tubing

2.3 Supply Tubing

The supply tubing run should be as short as possible. For flooded suction mounting, install a shut-off valve with an appropriate tubing connector at the tank outlet. Cut a length of tubing from the coil supplied and install between the shut-off valve and the pump inlet fitting. For suction lift applications, slide on the ceramic weight, then install a foot valve on one end of suction tubing. Cut the tubing to a length such that the foot valve hangs vertically about 1 in (25mm) above the bottom of the tank. Avoid any loops in the tubing run that could form a vapor trap. Running the tubing through a length of pipe will help to keep tubing straight. Total vertical suction lift should be no more than 5ft. (1.5m). Reference Figure 4.

Attach tubing as shown in Figure 5. First slide the coupling nut, small end first, onto the tubing. Push the tubing over the valve housing tip *all the way to the valve housing shoulder*. (Tip: if the tubing is stiff from cold, dip the tubing end in hot tap water for a few minutes so it will slide on and flare out more easily. Push the coupling nut onto the threads. Apply some pressure on the coupling nut and tubing while tightening the nut, making sure the tubing has not backed off of the shoulder of the valve housing.



WARNING: *All fittings and coupling nuts should be tightened by hand only. If necessary, a small tool may be used to make it snug. DO NOT use excessive force or large wrenches.*

The coupling nut should not bottom out completely against the fitting. If this happens during connection, either the tubing has slid down the shoulder while tightening, or the tubing has been pinched. Remove the coupling nut, re-cut the tubing and re-connect.



WARNING: *If there is any leakage around the coupling nut and it appears to have been installed correctly, DO NOT TIGHTEN the coupling further! Release pressure in the line, disconnect tubing, re-cut and re-connect. Tightening of misinstalled tubing may cause the tubing to pop off under pressure.*

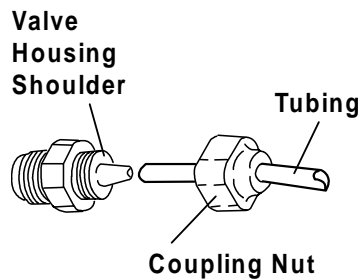

Figure 5 Attach Tubing

2.4 Discharge Tubing

Cut a length of tubing long enough to go from the pump to the application (injection) point. Additional tubing can be ordered from your distributor. Avoid sharp turns or bends and hot surfaces. Routing tubing through rigid pipe such as PVC pipe is recommended for long runs and/or as protective shielding against corrosive chemicals. If applicable, install the injection valve in 1/2" NPT thread at the injection point (see section 2.5) and connect the discharge tubing to the injection valve.

Attach tubing as described in section 2.3 and as shown in Figures 5 and 6. Note: Some models have an air vent valve with two outlet connections. The connection marked 'OUT' is the discharge side to the application point. (Fig 6). Attach a second length of tubing to the air vent side marked ('AIR') and route back to the chemical solution tank or drum. On the larger pumps (30 & 35 sizes), the air vent valve connections are not marked, however, the discharge side is the vertical (UP) connection and the air vent connection is on the side of the valve.

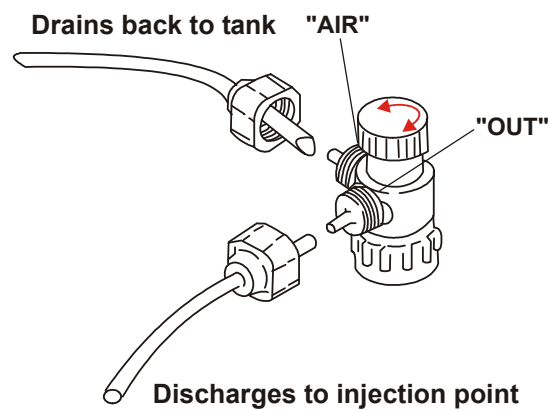

Figure 6 Air Vent Valve Tubing

2.5 Installing Injection/BackPressure Valve

A fitting or tee with 1/2" NPTF threads and with sufficient depth will accept the injection valve assembly. If required, trim off an amount of the extension tip until it fits your fitting or tee. (Fig. 7.)

The position of the injection/back pressure valve can be at any orientation as long as the spring is retained in the valve. **DO NOT REMOVE THE SPRING.** Be sure to check and replace the spring as needed. Attach the tubing following the same instructions in section 2.3, connecting the supply tubing.

CAUTION: Some chemicals may have reactions as they are injected into the main flow. For example, sulfuric acid may react with water causing excess heat.

If the chemical is heavier than water, mount the injection valve as close as possible to vertical coming into the bottom of the pipe. This will keep the injection nozzle facing up and keep the heavier chemistry from draining into the pipe and causing adverse reactions within the injection valve and pipe.

In addition to preventing backflow from pressurized lines, the injection valve acts as a back pressure valve when pumping into atmosphere or low pressure applications. However, the back pressure by the injection valve can vary and the valve does NOT act as an anti-siphon valve. If siphoning is a possibility, or if pumping downhill into open atmosphere (open tank), a Walchem MultiFunction valve or a separate back pressure/anti-siphon valve must be installed.

Note: Siphoning can also occur at the tip of the injection valve because of the high flow rate in the main pipe flowing past the small injection nozzle (venturi effect). In this case, an anti-siphon device must be installed to avoid over feeding or siphoning of chemistry.

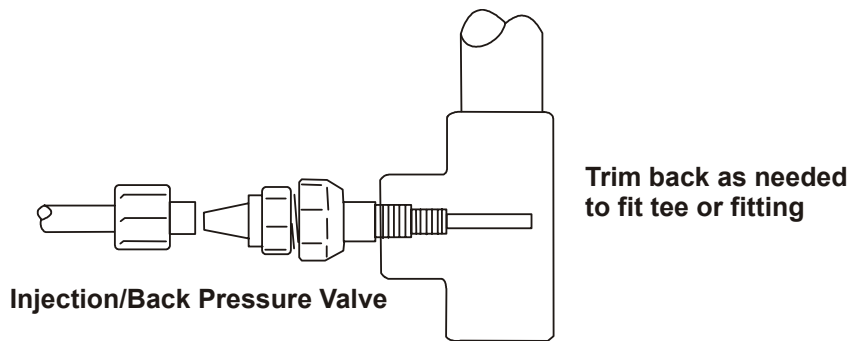

Figure 7 Injection Valve

See Section 5.0 for complete liquid ends parts list and exploded view.

2.6 Electrical



WARNING Risk of electrical shock! *This pump is supplied with a grounding conductor and grounding-type attachment plug. To reduce the risk of electrical shock, be certain that it is connected only to a properly grounded, grounding type receptacle.*

Connect the pump power cord to a **GROUND**ED outlet supplying proper voltage. Avoid branch circuits that also supply power to heavy machinery or other equipment that could generate electrical interference.

3.0 OPERATION

3.1 Priming

Install the pump as described above. With the pump turned on, set stroke length at 100% and frequency at 100%. If the pump is equipped with an air vent valve, open the knob 1/2 turn. Liquid should move through the suction tubing and into the pump head. When liquid starts running through the vent side tubing, close the air vent knob and continue with output adjustment described below. If the pump has no air vent valve, disconnect the discharge tubing from the injection valve. When liquid enters the discharge tubing at the pump head, stop the pump (set frequency knob to 0% on the R-Control module). Then reconnect the discharge tubing to the injection valve.

If the pump does not self prime, remove the check valve housing on discharge & suction sides to make sure valve cartridges and gaskets are in correct positions (see section 4.2 for correct orientation).

Note: Pumps with FC liquid ends should use flooded suction when priming, due to the hard valve seat material.

3.2 Adjustment

A. EZ Pumps using the 'D' Control Module

If less than full output is required, set the frequency to the appropriate percentage of maximum desired.

Example: Model EZB20D1-VE has maximum output of 1.5 GPH.

Desired output is 1.2 GPH. $1.2 \div 1.5 = 0.8$ or 80%

Set the frequency of the pump to $0.8 \times 360 = 288$ spm by pushing the UP or DOWN arrow keys.

B. EH Pumps using the 'R' Control Module

The pump will operate best with the stroke length at 100%. If less than full output is required, set the frequency to the approximate percentage of maximum desired.

Example: Model EHB20R1-VC has maximum output of 1.5 GPH.

Desired output is 1.2 GPH. $1.2 \div 1.5 = 0.8$ or 80%

Set the frequency knob at 80.

For outputs less than 2% of maximum it will be necessary to also reduce the stroke length. (Minimum recommended stroke length is 40%.)

C. EH Pumps using the 'Y' Control Module

The pump will operate best with the stroke length at 100%. If less than full output is required, set the frequency to the desired strokes per minute using the UP and DOWN arrow keys.

Example: Model EHB20Y1-VC has maximum output of 1.5 GPH.

Desired output is 1.2 GPH. $1.2 \div 1.5 = 0.8$ or 80%

Set frequency of the pump to $0.8 \times 360 = 288$ spm by pushing the UP or DOWN arrow keys.

For very low outputs it will be necessary to also reduce the stroke length. (Minimum recommended stroke length is 40%.)

3.3 Calibration

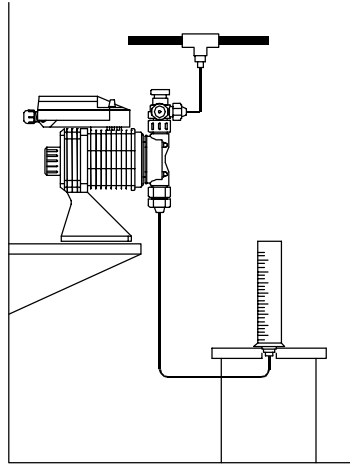

Figure 8 Calibration

If exact output calibration is required, first prime and adjust the pump as above. Then connect a calibration column to the suction side of the pump. Turn the pump on for one minute and read the amount of liquid pumped from the column. Adjust the frequency up or down as necessary and check the output again. When the desired output is reached, disconnect the calibration column and reconnect the suction tubing. (See Figure 8.) Calibration must be performed with application equivalent back pressure for accurate results.

3.4 External Control

(Not available on EZ pumps)

A. Pumps using the ‘R’ Control Module

For pulse proportional external control of pump frequency, connect the control signal leads to terminals 4 (positive) and 6 (common) inside the control module. The input signal should not exceed 360 pulses per minute. The control signal can be a contact closure type switch or solid state device, however the external circuit should be capable of switching 10 VDC at 2 mA with a pulse width of 10 ms to 100 ms. (See Figure 9.) Do not use a powered control signal.

In order for the pump to operate properly in External Mode, the frequency knob must be set fully counter clockwise so it points to the “E”. (See Figure 10.)

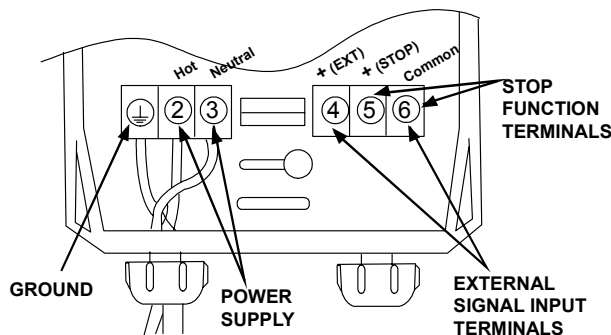

Figure 9

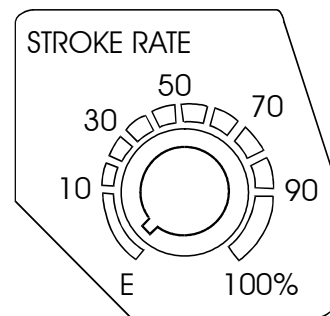

Figure 10

B. Pumps using the 'Y' Control Module

The EH-Y Series is able to operate in both digital and analog external modes. An external stop function is also available.

Display/Keypad Overview

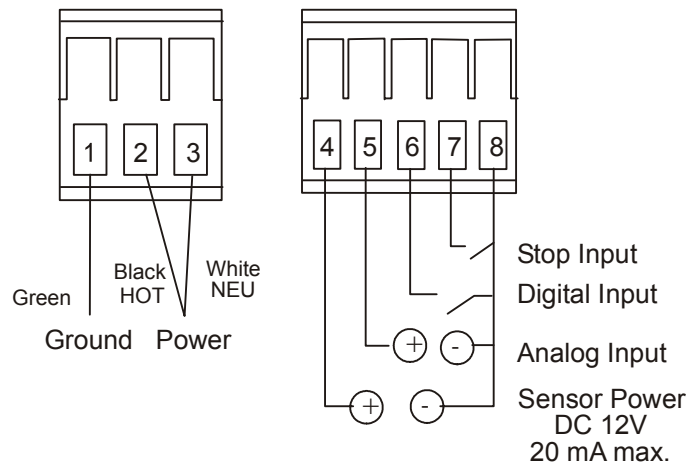
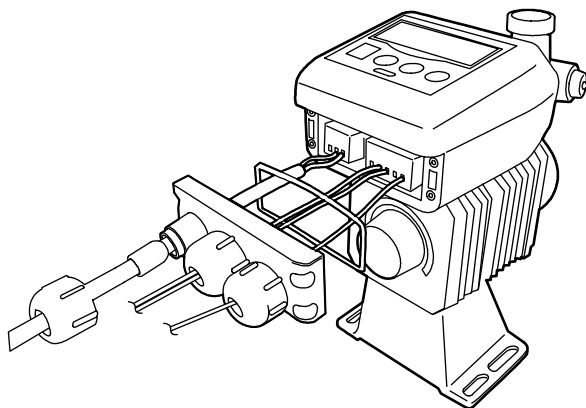
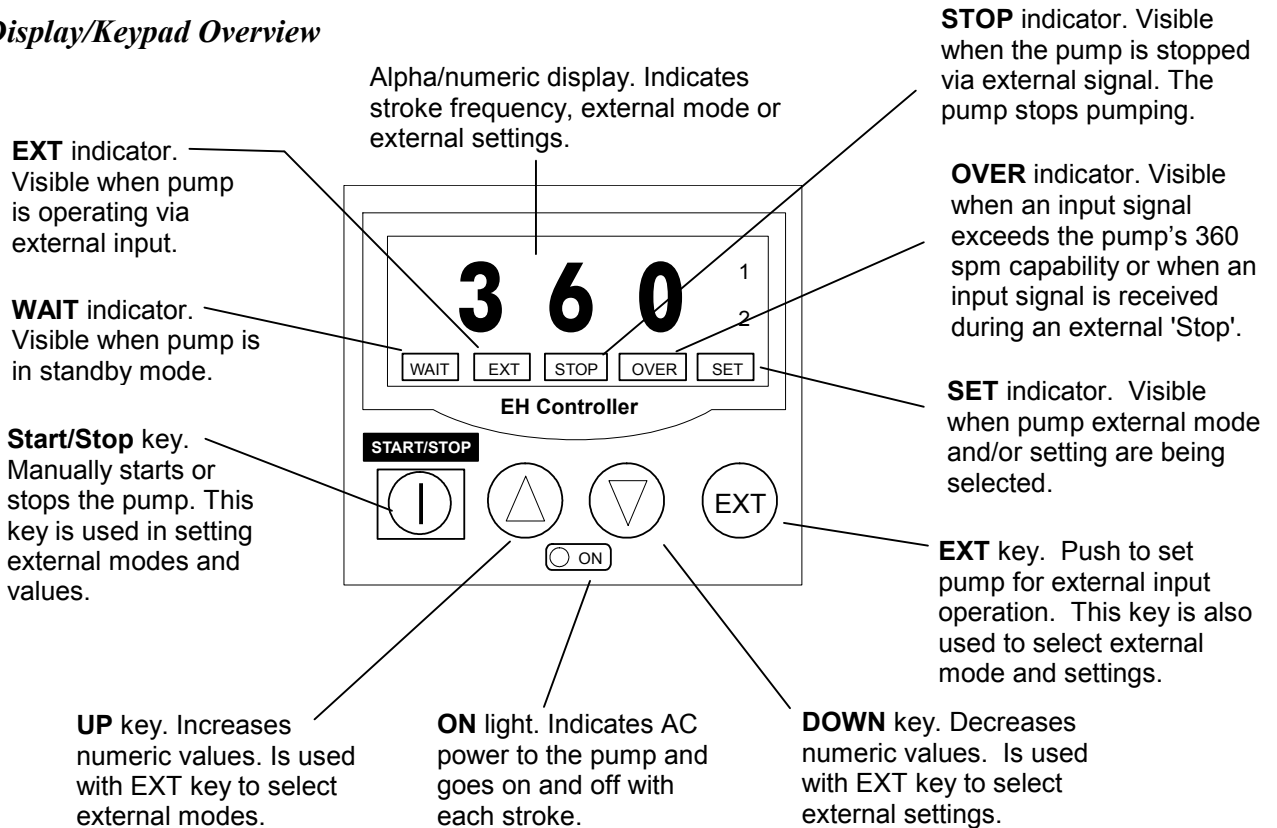
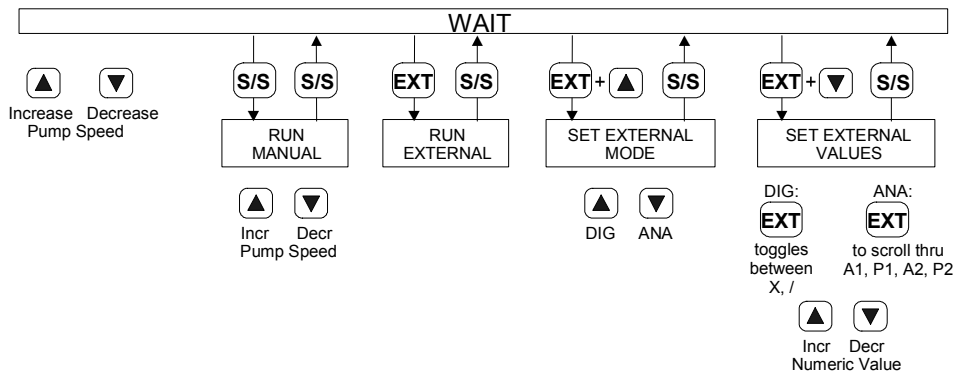

Figure 11 Input Wiring.

EH-Y Quick Reference Guide

S/S Start/Stop Key
 EXT External Key

FROM:	PRESS:	TO:
WAIT MODE	S/S	Run in manual mode
	▼	Decrease frequency (1 to 360 SPM)
	▲	Increase frequency (1 to 360 SPM)
	EXT	Run in EXT ternal mode
	EXT + ▲	SET external mode
	EXT + ▼	SET external values
RUNNING IN MANUAL MODE	▲	Decrease frequency (1 to 360 SPM)
	▼	Increase frequency (1 to 360 SPM)
	S/S	Return to WAIT and stop pump operation
RUNNING IN EXT MODE	S/S	Return to WAIT and stop pump operation
SET EXTERNAL MODE	▲ OR ▼	Toggles between DIG (multiply or divide) and ANA (milliamp input)
	S/S	Accept data and return to WAIT mode
SET EXTERNAL VALUES	DIG	
	EXT	Select '/' (divide) or 'X' (multiply)
	▲	Increase value (1 to 999)
	▼	Decrease value (1 to 999)
	S/S	Accept data and return to WAIT mode
	ANA	
	EXT	Scroll through the following selections: Analog signal level (point 1) Pump speed (point 1) Analog signal level (point 2) Pump speed (point 2)
	▲	Increase value (A from 0.00 to 20.0mA) (P from 0 to 360 SPM)
	▼	Decrease value (A and P)
	S/S	Accept data and return to WAIT mode
STOP	Indicates the external stop function has been activated	
OVER	Indicates one or more input pulses were received prior to completing action required by previous input pulse.	



Digital Mode

In digital mode, the pump accepts a non-powered pulse signal (contact closure type or solid state device) from a flowmeter or other instrument. The pump can be set to divide pulses by a factor of 1 to 999; or in multiply mode, 1 input pulse can produce 1 to 999 pump strokes. The minimum pulse width on the Y control module is 50 msec.

Connecting a digital input device

Disconnect AC power to the pump. Remove the four screws from the terminal block cover and remove the cover. Remove the cord nut and bushing from the terminal block cover. Remove the terminal block from the connector. Slide the nut and bushing over the external control cable and insert the cable through the terminal block cover. Strip 1/4" insulation from conductors and connect the positive side to terminal 6 and the negative side to terminal 8. (See schematic, below.)

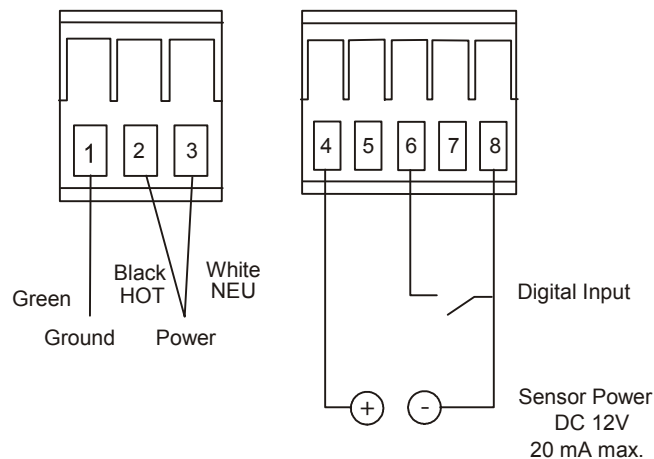

Connecting EH-R Pumps in Parallel for Pulse Control

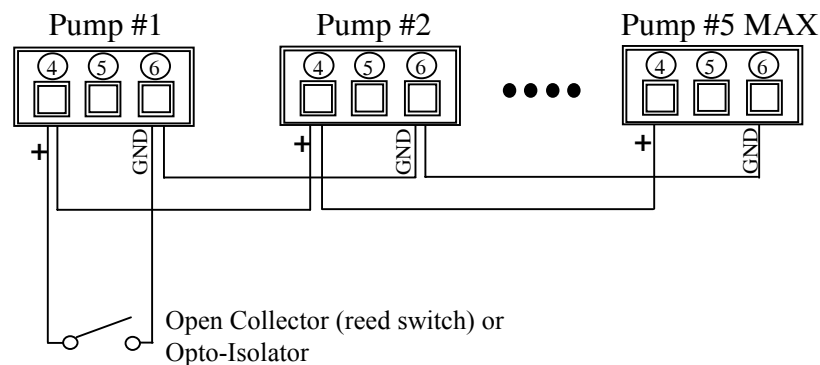

NOTES:

CAUTION: DO NOT SUPPLY ANY TYPE OF POWERED INPUT TO THE PUMPS!

Polarity Sensitive. Be sure to connect the POSITIVE to POSITIVE and GND to GND with each connection. ONLY a contact closure is acceptable or damage to the pumps will occur.

Maximum current rating of the pump input is 10mA. Each pump draws approximately 2mA. There is a 5 PUMP LIMIT of pumps in parallel.

Make sure the switching device can handle the maximum current in the system.

For Y-Control Modules: Connection is the same as above, except the POSITIVE terminal is Terminal # 6 and the GND is Terminal #8

Sensor Power

The control circuit of the Y Module has the ability to provide 12 VDC at up to 20 mA to power a Hall effect sensor or similar device. Connect the sensor power leads to terminal 4 (positive) and terminal 8 (negative) of the terminal block.

Settings

Start with pump in the **WAIT** state. If it is not currently in wait, press **START/STOP** once.

1. Set it to digital mode

Press and **EXT** simultaneously.

The **SET** indicator is highlighted and DIG (digital) or ANA (analog) will be displayed.

If DIG is displayed, press **START/STOP** to accept that mode.

You will be returned to the **WAIT** state.

If ANA is displayed, press to change to **DIG** and then press **START/STOP** to enter that choice.

You will be returned to the **WAIT** state.

2. Set multiply or divide

To set values for digital operation, press **EXT** and simultaneously. The display will show '/' or 'X' and a number. Now pressing the **EXT** button will alternate between X (multiply) and / (divide).

3. Set the value

or will increase or decrease the multiplier or divider. Pressing a button once will change the value by one. Holding a button down will continuously increment or decrement the value, slowly at first, then rapidly. Press **START/STOP** to accept values and return to **WAIT**.

Press **EXT** to operate the pump in external mode. The pump will now respond to the incoming pulse signal. The stroke length can be adjusted manually to set the volume pumped per stroke.

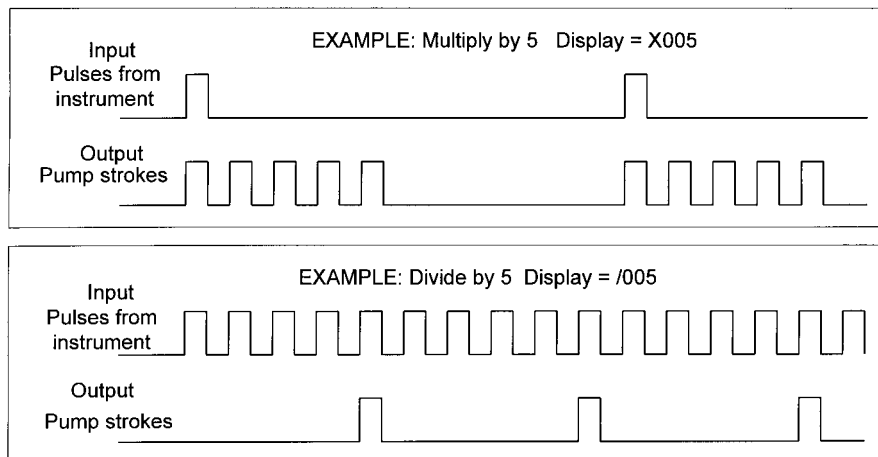

Analog Mode

In analog mode the pump will accept a milliamp signal and produce a pump speed proportional to the signal level received. The input resistance of this signal is 250 Ω . The pump's response can be fine-tuned by variable set points to meet system requirements.



CAUTION: Open loop signal voltage must not exceed 25 VDC. If the signal voltage is greater than 25 VDC, power down the signal source prior to connection and any open loop condition.

Connecting an analog signal device

Disconnect AC power to the pump. Remove the four screws from the terminal block cover and remove the cover. Remove the cord nut and bushing from the terminal block cover. Remove the terminal block from the connector. Slide the nut and bushing over the external control cable and insert the cable through the terminal block cover. Strip 1/4" insulation from conductors and connect the positive side to terminal 5 and the negative side to terminal 8. (See schematic below.)

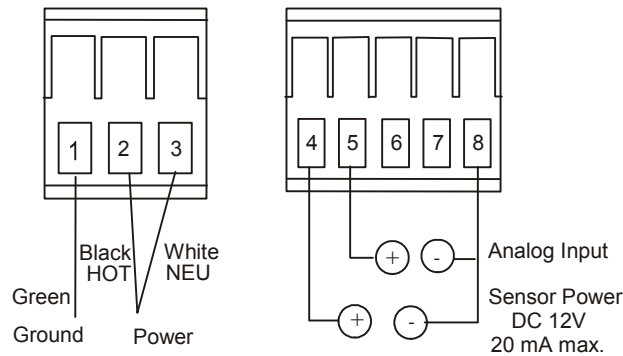

Output Power

The control circuit of the Y control module has the ability to provide 12 VDC to power a loop powered device. Wiring is as follows:

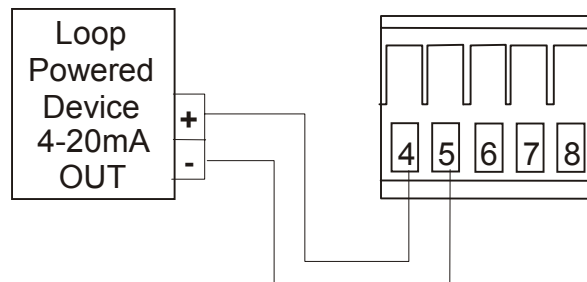

Settings

The pump's response to a 4 to 20 milliampere signal can be adjusted to meet almost any need. The adjustment is done by selecting two points. A signal level and a pump speed are entered for each point. These two points determine a straight line and the pump speed resulting from any given signal will be defined by that line. The factory settings for point 1 are 4.0 mA, 0 spm and for point 2 are 20.0 mA, 360 spm. An 'A' in the leftmost position of the display indicates the data shown is Analog signal level. A 'P' indicates Pump speed. The 1 on the right side of the display is highlighted when viewing or changing data for point 1. The 2 is highlighted to indicate data for point 2.

Start with pump in the **WAIT** state. If it is not currently in wait, press **START/STOP** once.

1. Set analog mode.



Press  and **EXT** simultaneously.



The **SET** indicator is highlighted and DIG (digital) or ANA (analog) will be displayed.

If ANA is displayed, press **START/STOP** to accept that mode. You will be returned to the **WAIT** state.

If DIG is displayed, press  to change to ANA and then press **START/STOP** to enter that choice. You will be returned to the **WAIT** state.

2. Set values

To set values for analog operation, press **EXT** and  simultaneously. The display will show A04.0 (or some value between 00.0 and 20.0 mA) with the point 1 indicator highlighted. Press  or  to adjust the value to the desired analog signal level for point 1.

Press **EXT** to display the pump speed for point 1. The display will show P0 (or some value between 0 and 360 spm) with the point 1 indicator highlighted. Press  or  to adjust the value to the desired pump speed for point 1.

Press **EXT** again to display the analog signal level for point 2, which can be adjusted as for point 1. Pressing **EXT** a third time will display the pump speed for point 2m which can be adjusted as for point 1.

Continued pressing of **EXT** key will scroll through the above four parameters for review or adjustment. When settings are as desired, press **START/STOP** to accept the new values and return to **WAIT**.

Press **EXT** to operate the pump in external mode. The pump speed will now be determined by the level of the milliamp signal as shown in the graph. The stroke length can be adjusted manually to set the volume pumped per stroke.

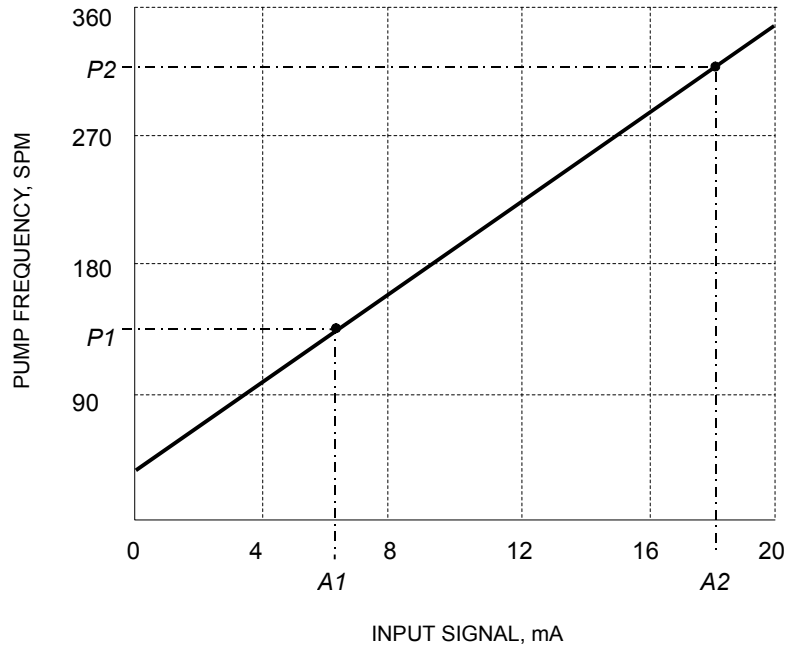

C. Pumps using the 'T' Control Module

The EZB-Timer Series is able to operate in Daily, Weekly and 2-Week modes. An external stop input and 12VDC output are also available.

Display/Keypad Overview

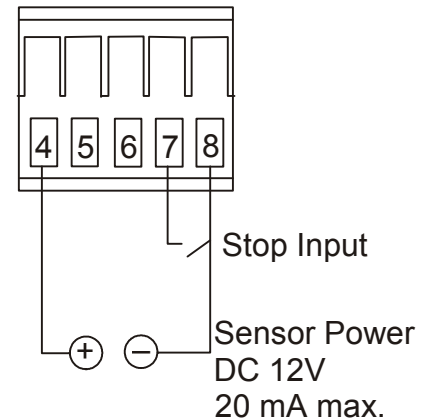
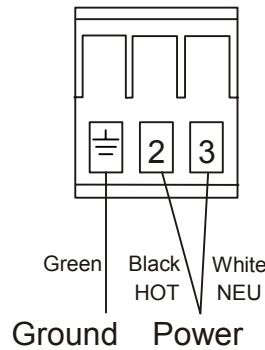
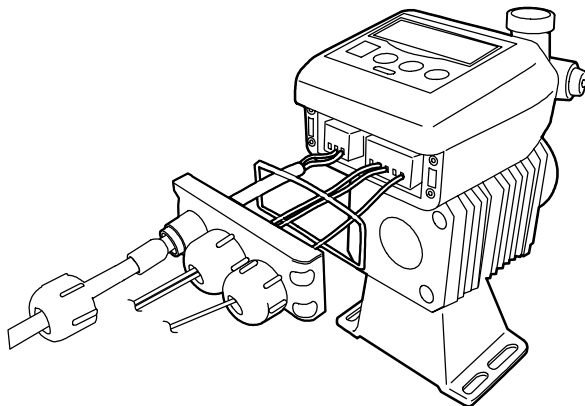
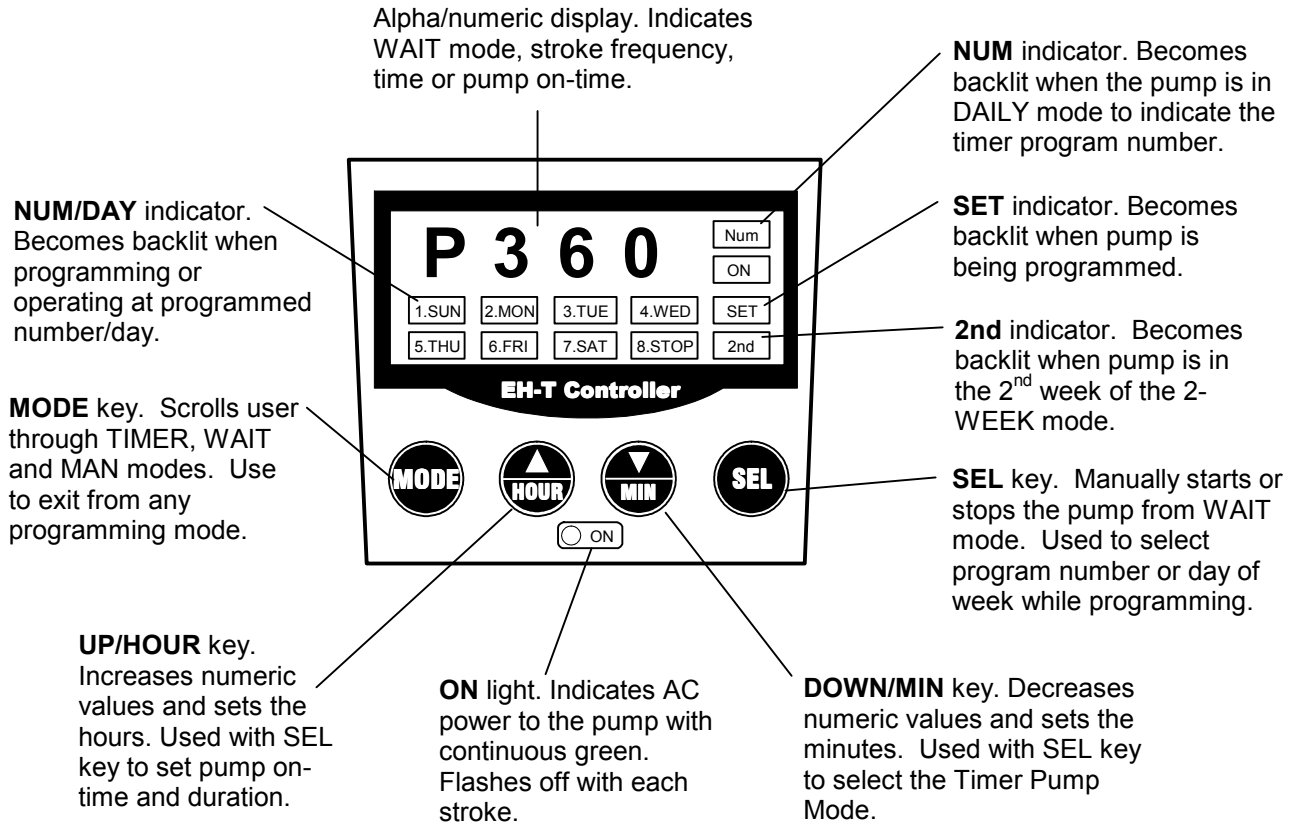

EZ-T Quick Reference Guide

(MODE) Mode Key

(SEL) Select Key

FROM:	PRESS:	TO:
TIMER RUN MENU	(MODE)	Move to WAIT menu
WAIT MENU	(MODE)	Move to MANUAL menu
	(SEL) (Hold for 3 seconds)	Move to TIME / DATE setting menu
	(SEL) + (▲) HOUR	Move to TIMER programming menu
	(SEL) + (▼) MIN	Move to TIMER MODE selection menu
MANUAL MENU	(MODE)	Move to TIMER RUN mode (shows TIME)
	(SEL)	Starts and stops manual operation
	(▼) MIN OR (▲) HOUR	Changes pump frequency (1 to 360 SPM)
TIME / DATE MENU (24 Hour Clock)	(▲) HOUR	Sets the Hour (incrementing only)
	(▼) MIN	Sets the Minutes (incrementing only)
	(SEL)	Selects the Day of the week
	(MODE)	Exits back to WAIT menu
TIMER MODE MENU	(▲) HOUR OR (▼) MIN	Scrolls between DAILY, WEEK or 2-WEEK Timer modes
	(MODE)	Exits back to WAIT menu
TIMER PROGRAMMING MENU	(▲) HOUR	Sets the Hour / Sets On-Time Minutes
	(▼) MIN	Sets the Minutes / Sets On-Time Minutes
	(SEL)	Scrolls through the week days / program #
	(MODE)	Exits back to WAIT menu

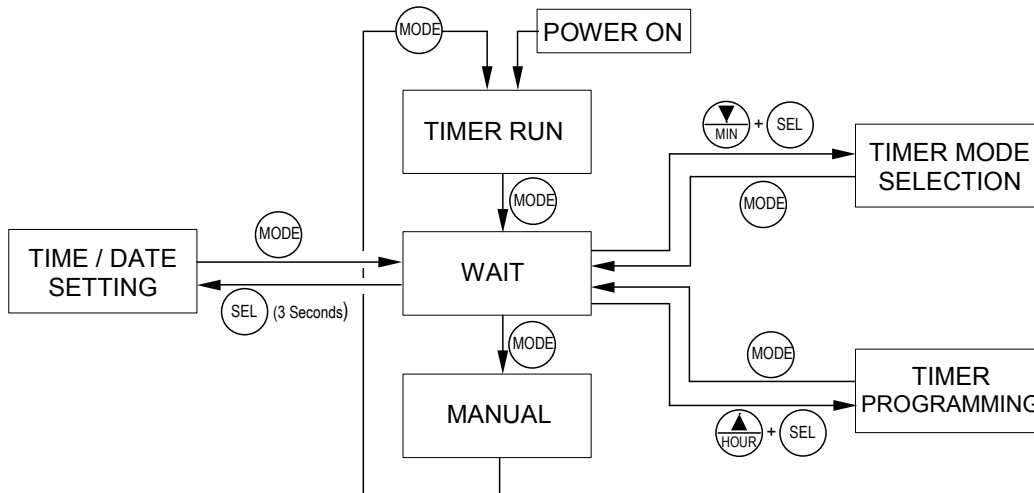

Programming and Timer Use

CAUTION! Before use, check the time and date. Set to the local time and date before programming. Incorrect time/date can result in incorrect operation.

1. Manual Operation

From the WAIT menu, pressing the MODE key will enter the manual mode. Pressing SEL will toggle the pump on and off manually. The speed can be changed with the UP and DOWN arrows both running and waiting. **NOTE: The pump speed set in this menu will be the speed that the pump will run during timed operations.**

2. Time/Date Setting

From the WAIT menu, holding the SEL key down for 3 seconds will enter into the Time/Date SET menu. Using the HOUR and MIN keys, the time can be set using a 24-hour clock. The SEL key will cycle through the days of the week. Once the correct time and day of the week are set, pressing the MODE key will go back to the WAIT menu.

3. Timer Mode Selection

Pressing the MIN and SEL keys at the same time will bring up the Mode Selection menu. This menu is where the Timer module is set to control in daily, weekly, or in 2-week modes. Use the UP and DOWN keys to cycle through the three options and MODE to get back to the WAIT menu. Daily mode allows a max of up to 8 timed operations repeated every day. Weekly and 2-week modes allow a max of one timed operation per day.

4. Timer Operation Programming

Pressing the HOUR and SEL keys at the same time will bring up the Timer Programming menu. This menu is where the individual operations are set – both start time and run time.

DAILY MODE:

Initially, the 1-SUN and NUM will both be backlit. NUM is backlit to signal that the number backlit is used – i.e. program 1 in this case. Using the HOUR and MIN keys, the time for the first program can be set (24-hour clock). Pressing the SEL key will change the menu to program the on-time to run the pump (initially shows “ 0M”). Use the UP and DOWN keys to program the # of minutes for the pump to run. Pressing SEL again will then move to program the second program and the backlight will move from 1-SUN to 2-MON. The clock and on-time settings are set in the same manner. Pressing MODE will go back to the WAIT menu.

WEEKLY MODE:

Initially, the 1-SUN will be backlit signifying that Sunday is being programmed. If a program is desired for Sunday, use the HOUR and MIN keys to set the time of the program. If no program is desired for Sunday, pressing the SEL key will scroll through each day’s two programmed settings – the time to start and the run time. Pressing MODE will go back to the WAIT menu at any point in the programming.

2-WEEK MODE:

Two week mode is similar and set just as the weekly mode, only after the first 7-SAT is programmed or passed by and 1-SUN is again backlit, the “2nd” will also become backlit showing that the day is in

the 2nd week. All programming functions are the same and SEL will scroll through each setting. Pressing MODE will go back to the WAIT menu at any point in the programming.

From the WAIT mode, pressing MODE will move to the MANUAL menu. Check to make sure that the pump speed is set at the rate desired during the timed operations. If not, use the UP and DOWN keys to change the pump speed.

Pressing MODE again will display the current time and date. The pump is now operating in the TIMER mode and will come on at the next programmed timer operation.

3.5 STOP Function

Additionally, the EH pumps can be controlled in start-stop mode. In this mode, AC power is applied continuously and pump operation is stopped by completing the circuit between the positive ‘stop’ and common terminals inside the control module (R Control Module: 5 (positive) and 6 (common) Y Control Module: 7 (positive) and 8 (common)). A switch or solid state device capable of switching 10 VDC at 2 mA for the R-Module and 5VDC at 2 mA for the Y-Module. should be used. Switch closed = pump stopped, switch open = pump running at the speed determined by the frequency knob setting. This feature eliminates the need for a high voltage, high current AC relay to start and stop the pump. (See Figures 9 and 11.)

If using the Y Control Module and the pump is operating in external digital mode, any pulses received while the pump is stopped will be saved (up to a maximum of 255). When pump operation resumes, saved pulses will allow the pump to “catch up” by producing the correct number of pump strokes that should have occurred while it was stopped.

3.6 AC Power Interruption (Y-Control Module)

If AC power is interrupted, the pump will power up as shown below:

State preceding power OFF	State following power ON
WAIT	WAIT
Run Manual	Run Manual
Run external	Run external
Set EXTERNAL mode	WAIT
Set External values	WAIT

3.7 Auto Air Vent Valve Operation

The Auto Air Vent Valve is an option on select EH and EZ pumps and replaces the standard Manual Air Vent Valve when ordered. It is used primarily in applications where gassing is a problem and pumps can lose prime.

Unlike the Manual Air Vent Valve, the Auto Air Vent Valve constantly bleeds a controlled amount of volume out of the “Air” vent. Therefore, the “Air” vent should ***always*** be plumbed back to the source tank. During priming, the access knob does not have to be loosened as with a manual air vent valve as pressure is relieved through the vent. The Top Valve Guide assembly uses a bottom seat to ensure that air is not introduced into the discharge media and utilizes a precisely machined top seat that allows air to be quickly purged but limits the amount of liquid returned to the tank. A sleeve valve is used to maintain backpressure within the pump head, which helps speed the purging of air.

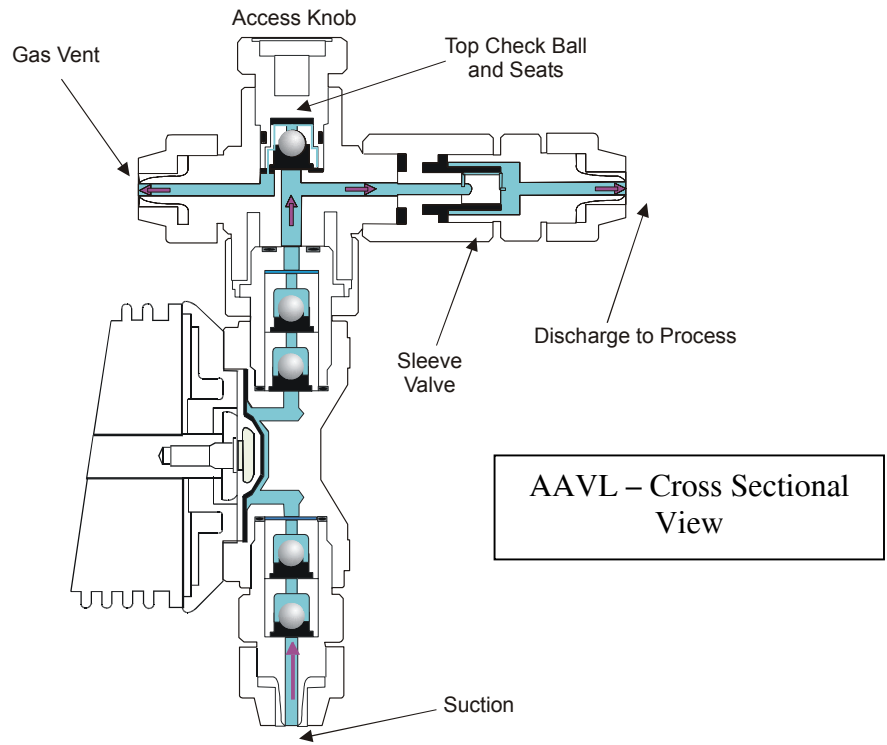

3.8 MultiFunction Valve Operation

The MultiFunction Valve is optional on select EH and EZ pumps and replaces the standard Manual Air Vent Valve when ordered. It integrates the air venting/bleeding functions with a back pressure and anti-siphon valve.

Air Vent / Bleed Function

1. Open the air vent by turning the air vent adjustment knob counter-clockwise one to one and a half turns.
2. Operate the pump until all of the air is purged and only liquid is discharged from the air vent drain.
3. Turn the air vent adjustment knob clockwise until it bottoms out and will not turn further.

Back Pressure / Anti-Siphon Valve

1. A spring-loaded diaphragm automatically adds 30PSI of back pressure to the discharge side of the pump when the air vent adjustment knob is closed.
2. If back pressure is not observed, the pressure release knob may be in the release position (the knob is resting in its 'up' location). If this is the case, turn the knob clockwise until it 'clicks' down (approximately ¼ turn).
3. The diaphragm prevents siphoning of chemical through the pump.

Pressure Release

1. Stop the pump operation.
2. Turn the pressure release knob clockwise until it 'clicks' into the release or 'up' location (approximately ¼ turn). If the knob is turned too far, it will 'click' again return to the back pressure or 'down' position. If this happens, keep turning the knob clockwise until it 'clicks' one time in the release ('up') position.
3. Turn the air vent adjustment knob counter-clockwise one or one and a half turns to release the pressure in the discharge tubing/piping through the air vent drain. The air vent drain should always be plumbed back to the supply tank or to safe disposal. Do not submerge the air vent drain tubing under chemical in the supply tank.

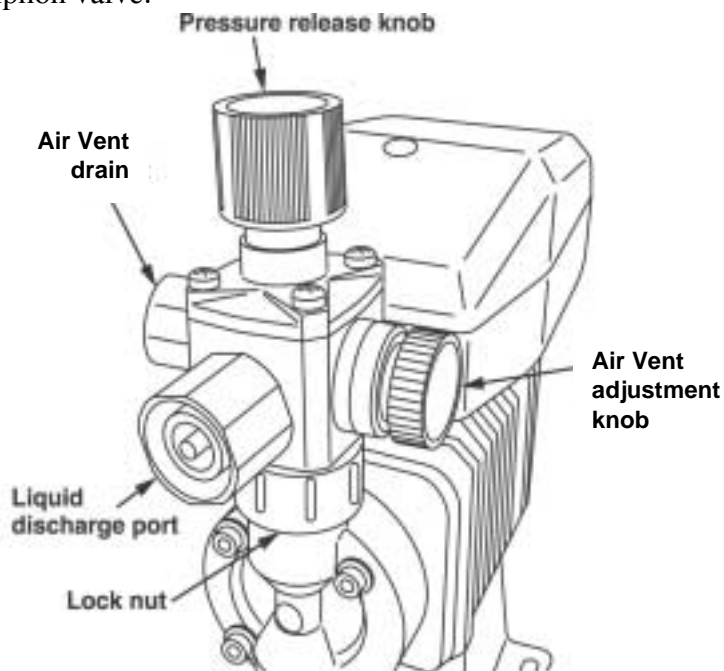

CAUTION: Confirm that liquid is discharged from the air vent drain. If the liquid is not discharged, the pressure may not be released. If this is the case, repeat the Pressure Release procedure.

4.0 MAINTENANCE

CAUTION: Before working on the pump, disconnect the power cord, depressurize the discharge tubing and drain or flush any residual liquid from the pump head and valves. Always wear protective gear when working around chemicals.

4.1 Diaphragm Replacement

Disconnect AC power to the pump and disconnect the suction tubing, discharge tubing, and air vent tubing. Remove the four head bolts with a 4mm or 5mm hex wrench. Turn the stroke length knob fully counter-clockwise. Unscrew the diaphragm and remove its retainer (small disk behind the diaphragm).

CAUTION: *There may be small brass spacers between the retainer and the armature shaft. These spacers need to be reused when replacing the diaphragm.* Install the new retainer and diaphragm on the shaft. Turn the diaphragm clockwise until it bottoms on the shaft. Replace the pump head and tighten the head bolts to a torque of 19 lb-in (2.16 N-m).

4.2 Valve Replacement

Remove the suction and discharge tubing making sure discharge side has been depressurized. Remove the suction fitting, two valve cartridges, o-ring and gasket(s). Install the new o-ring, gasket(s) and valve cartridges. Be sure both valve seats are in the same orientation. Refer to Figure below. Tighten the suction fitting. Similarly remove and replace the discharge valve cartridges, o-ring and gasket(s). For a more detailed drawing, refer to the Section 6.0.

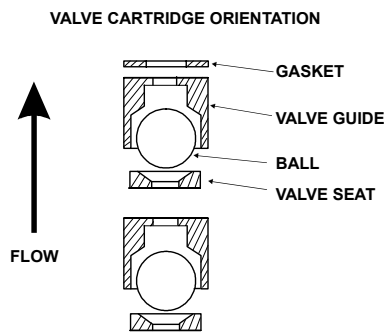

Valve Cartridge Orientation

CAUTION: *There are many small parts in the liquid end. These parts must be installed correctly for proper operation of the pump.*

4.3 Tubing

Check ends of tubing for splits, cracks, or thin spots. Examine the full length of tubing for damage due to chafing, abrasion, stress cracks, excessive temperature or exposure to ultraviolet light (direct sunlight or mercury vapor lamps). If any signs of deterioration exist, replace the entire length of tubing. It is a good idea to replace discharge tubing on a regular preventive maintenance schedule every 12 months.

5.0 EXPLODED VIEW & PARTS GUIDE

PVC/GFRPP Liquid End Exploded View #1

For EH and EZ pump model sizes 10, 15, and 20

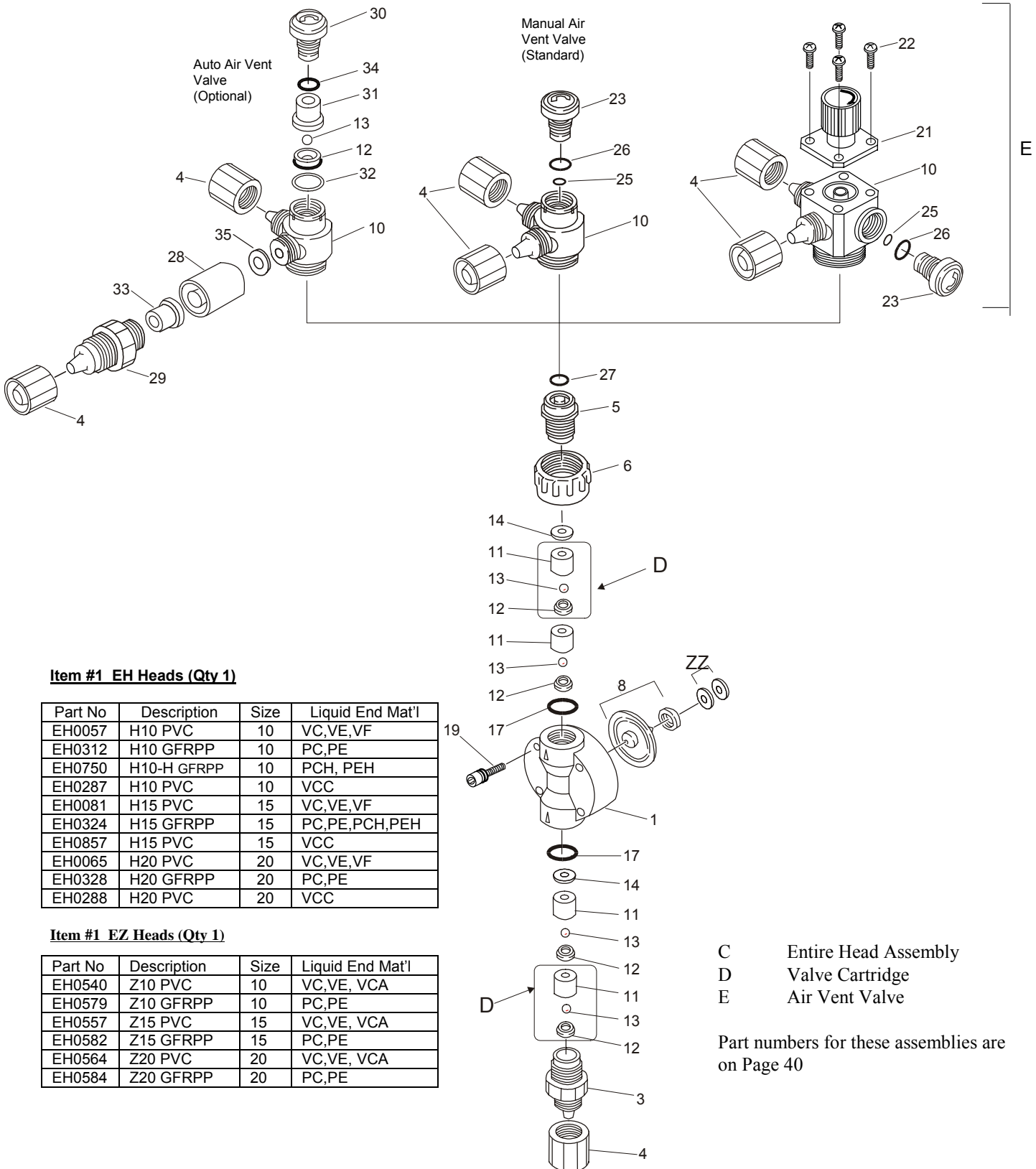

Item #1 EH Heads (Qty 1)

Part No	Description	Size	Liquid End Mat'l
EH0057	H10 PVC	10	VC,VE,VF
EH0312	H10 GFRPP	10	PC,PE
EH0750	H10-H GFRPP	10	PCH, PEH
EH0287	H10 PVC	10	VCC
EH0081	H15 PVC	15	VC,VE,VF
EH0324	H15 GFRPP	15	PC,PE,PCH,PEH
EH0857	H15 PVC	15	VCC
EH0065	H20 PVC	20	VC,VE,VF
EH0328	H20 GFRPP	20	PC,PE
EH0288	H20 PVC	20	VCC

Item #1 EZ Heads (Qty 1)

Part No	Description	Size	Liquid End Mat'l
EH0540	Z10 PVC	10	VC,VE, VCA
EH0579	Z10 GFRPP	10	PC,PE
EH0557	Z15 PVC	15	VC,VE, VCA
EH0582	Z15 GFRPP	15	PC,PE
EH0564	Z20 PVC	20	VC,VE, VCA
EH0584	Z20 GFRPP	20	PC,PE

C Entire Head Assembly
 D Valve Cartridge
 E Air Vent Valve

Part numbers for these assemblies are on Page 40

PVC/GFRPP Liquid End Exploded View #1

Components

Item	Part No	Description	Qty	Size	Liquid End Mtl	Series	
3	EH0400	Housing, Valve, 3/8 PVC	1	10, 15, 20	VC, VE, VF	EH, EZ	
	EH0418	Housing, Valve, 3/8 GFRPP	1	10, 15, 20	PC, PE	EH, EZ	
4	EH0401	Nut, Coupling, 3/8 PVC	3	10, 15, 20	VC, VE, VF	EH, EZ	
	EH0419	Nut, Coupling, 3/8 GFRPP	3	10, 15, 20	PC, PE	EH, EZ	
5	EH0294	Fitting, Air Vent, PVC	1	10, 15, 20	VC, VE, VF	EH, EZ	
	EH0315	Fitting, Air Vent, GFRPP	1	10, 15, 20	PC, PE	EH, EZ	
6	EH0295	Nut, Lock, Air Vent, PVC	1	10, 15, 20	VC, VE, VF	EH, EZ	
	EH0316	Nut, Lock, Air Vent, GFRPP	1	10, 15, 20	PC, PE	EH, EZ	
*	E90059	Diaphragm and Retainer, H10	1	10	VC, VE, VF, PC, PE	EH	
	E90311	Diaphragm and Retainer, H10-H	1	10	PCH, PEH	EH	
	E90060	Diaphragm and Retainer, H15	1	15	VC, VE, VF, PC, PE	EH	
	E90312	Diaphragm and Retainer, H15-H	1	15	PCH, PEH	EH	
	E90061	Diaphragm and Retainer, H20	1	20	all	EH	
	E90064	Diaphragm and Retainer, Z10	1	10	all	EZ	
	E90065	Diaphragm and Retainer, Z15	1	15	all	EZ	
	E90066	Diaphragm and Retainer, Z20	1	20	all	EZ	
10	EH0402	Body, Manual Air Vent, PVC	1	10, 15, 20	VC, VE, VF	EH, EZ	
	EH0420	Body, Manual Air Vent, GFRPP	1	10, 15, 20	PC, PE	EH, EZ	
	EH0861	Body, Auto Air Vent, PVC	1	10, 15, 20	VCA, VCC	EH, EZ	
	EH1406	Body, Multifunction Valve, PVC	1	10, 15, 20	VCM, VEM, VFM	EH, EZ	
	EH1407	Body, Multifunction Valve, GFRPP	1	10, 15, 20	PCM, PEM	EH, EZ	
*	11	EH0060	Guide, Valve, .188 PVC	4	10	VC, VE, VF	EH, EZ
	EH0318	Guide, Valve, .188 GFRPP	4	10	PC, PE	EH, EZ	
	EH0068	Guide, Valve, .250 PVC	4	15, 20	VC, VE, VF	EH, EZ	
	EH0325	Guide, Valve, .250 GFRPP	4	15, 20	PC, PE	EH, EZ	
*	12	EH0061	Seat, Valve, .188 FKM	4 (5)	10	VC, PC (VCA, VCC)	EH, EZ
	EH0048	Seat, Valve, .188 EPDM	4	10	VE, PE, VF	EH, EZ	
	EH0069	Seat, Valve, .250 FKM	4	15, 20	VC, PC	EH, EZ	
	EH0071	Seat, Valve, .250 EPDM	4	15, 20	VE, PE, VF	EH, EZ	
*	13	EH0025	Ball, Valve, .188 CE	4 (5)	10	VC, VE, PC, PE, (VCA, VCC)	EH, EZ
	EH0084	Ball, Valve, .250 CE	4	15, 20	VC, VE, PC, PE	EH, EZ	
	E00063	Ball, Valve 0.188 PTFE	4	10	VF	EH, EZ	
	E00064	Ball, Valve 0.250 PTFE	4	15, 20	VF	EH, EZ	
*	14	EH0026	Gasket, Valve, .188 & .250 PTFE	2	10, 15, 20	VC, VE, VF	EH, EZ
	EH0580	Gasket, Valve, .188 & .250 PTFE	2	10, 15, 20	PC, PE	EH, EZ	
*	17	EH0027	O-Ring, S14 FKM	2	10, 15, 20	VC, PC	EH, EZ
	EH0050	O-Ring, S14 EPDM	2	10, 15, 20	VE, PE, VF	EH, EZ	
19	EH0742	Bolt, M4 x 33 SS Hex Socket	4	10, 15, 20	all	EH, EZ	
	E90374	Multifunction Valve Top Asm	1	10, 15, 20	all xxM ends	EH, EZ	
22	EH1410	Screw, M4 x 10, SS304, PP	4	10, 15, 20	all xxM ends	EH, EZ	
23	EH0299	Knob, Manual Air Vent Valve, PVC	1	10, 15, 20	VC, VE, VF	EH, EZ	
	EH0321	Knob, Manual Air Vent Valve, GFRPP	1	10, 15, 20	PC, PE	EH, EZ	
*	25	EH0300	O-Ring, P4 FKM	1	10, 15, 20	VC, PC	EH, EZ
	EH0301	O-Ring, P4 EPDM	1	10, 15, 20	VE, PE, VF	EH, EZ	
*	26	EH0302	O-Ring, P10A FKM	1	10, 15, 20	VC, PC	EH, EZ
	EH0303	O-Ring, P10A EPDM	1	10, 15, 20	VE, PE, VF	EH, EZ	
*	27	EH0304	O-Ring, P7 FKM	1	10, 15, 20	VC, PC	EH, EZ
	EH0305	O-Ring, P7 EPDM	1	10, 15, 20	VE, PE, VF	EH, EZ	
28	EH0864	Fitting, Adapter, AAVV, PVC	1	10, 15, 20	VCA, VCC	EH, EZ	
29	EH0867	Fitting, AAVV, PVC	1	10, 15, 20	VCA, VCC	EH, EZ	
30	EH0774	Knob, AAVV, PVC	1	10, 15, 20	VCA, VCC	EH, EZ	
31	EH0862	Guide, Valve, AAVV, Titanium	1	10, 15, 20	VCA, VCC	EH, EZ	
32	EH0775	Spacer, AAVV, PVC	1	10, 15, 20	VCA, VCC	EH, EZ	
33	EH0865	Tube, Valve, AAVV, FKM	1	10, 15, 20	VCA, VCC	EH, EZ	
34	EH0776	O-Ring, S12, FKM	1	10, 15, 20	VCA, VCC	EH, EZ	
35	EH0866	Gasket, AAVV, FKM	1	10, 15, 20	VCA, VCC	EH, EZ	
ZZ	-----	Brass Spacers				Drive specific/Reuse when replacing diaphragm	
*	Included in spare parts kit						

PVC/GFRPP Liquid End Exploded View #2
 For EH and EZ pump model sizes 30 and 35

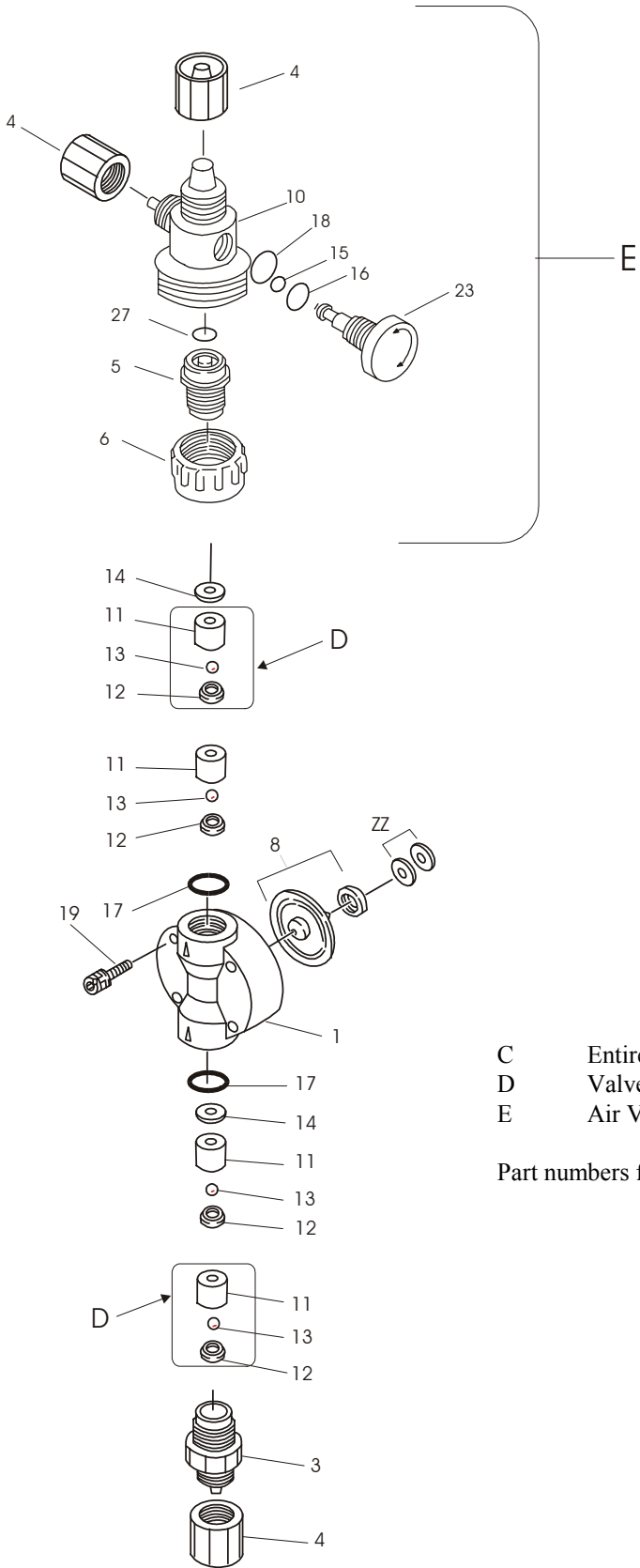

- C Entire Head Assembly
- D Valve Cartridge
- E Air Vent Valve

Part numbers for these assemblies are on Page 40

PVC/GFRPP Liquid End Exploded View #2

Components

Item	Part No	Description	Qty	Size	Liquid End Mtl	Series	
1	EH0329	Head, H30 GFRPP	1	30	PC, PE	EH	
	EH0113	Head, H30 PVC	1	30	VC, VE, VF	EH	
	EH0585	Head, Z30, GFRPP	1	30	PC, PE	EZ	
	EH0570	Head, Z30, PVC	1	30	VC, VE, VF	EZ	
	EH0336	Head, H35 GFRPP	1	35	PC, PE	EH	
	EH0156	Head, H35 PVC	1	35	VC, VE, VF	EH	
	EH1341	Head, Z35, PVC	1	35	VC, VE, VF	EZ	
	EH1346	Head, Z35, GFRPP	1	35	PC, PE	EZ	
3	EH0405	Housing, Valve, 1/2 PVC	1	30, 35	VC, VE, VF	EH, EZ	
	EH0421	Housing, Valve, 1/2 GFRPP	1	30, 35	PC, PE	EH, EZ	
4	EH0406	Nut Coupling, 1/2 PVC	3	30, 35	VC, VE, VF	EH, EZ	
	EH0422	Nut, Coupling, 1/2 GFRPP	3	30, 35	PC, PE	EH, EZ	
5	EH1078	Fitting, Air Vent, PVC	1	30, 35	VC, VE, VF	EH, EZ	
	EH1088	Fitting, Air Vent, GFRPP	1	30, 35	PC, PE	EH, EZ	
6	EH1077	Nut, Lock, Air Vent, PVC	1	30, 35	VC, VE, VF	EH, EZ	
	EH1087	Nut, Lock, Air Vent, GFRPP	1	30, 35	PC, PE	EH, EZ	
*	8	E90062	Diaphragm and retainer, H30	1	30	all	EH
	E90067	Diaphragm and retainer, Z30	1	30	all	EZ	
	E90063	Diaphragm and retainer, H35	1	35	all	EH	
	E90490	Diaphragm & Retainer, Z35	1	35	all	EZ	
10	EH1101	Body, Manual Air Vent, PVC	1	30, 35	VC, VE, VF	EH, EZ	
	EH1099	Body, Manual Air Vent, GFRPP	1	30, 35	PC, PE	EH, EZ	
*	11	EH0118	Guide, Valve, 0.375 PVC	4	30, 35	VC, VE, VF	EH, EZ
	EH0332	Guide, Valve, 0.375 GFRPP	4	30, 35	PC, PE	EH, EZ	
*	12	EH0119	Seat, Valve, 0.375 FKM	4	30, 35	VC, PC	EH, EZ
	EH0125	Seat, Valve, 0.375 EPDM	4	30, 35	VE, PE, VF	EH, EZ	
*	13	EH0120	Ball, Valve, 0.375 CE	4	30, 35	VC, VE, PC, PE	EH, EZ
	E00062	Ball, Valve, 0.375 PTFE	4	30, 35	VF	EH	
*	14	EH0121	Gasket, Valve, 0.375 PTFE	2	30, 35	VC, VE, PC, PE, VF	EH, EZ
*	15	EH1080	O-Ring, P-3, FKM	1	30, 35	VC, PC	EH, EZ
	EH1083	O-Ring, P-3, EPDM	1	30, 35	VE, PE, VF	EH, EZ	
*	16	EH0029	O-Ring, P-6, FKM	1	30, 35	VC, PC	EH, EZ
	EH0052	O-Ring, P-6, EPDM	1	30, 35	VE, PE, VF	EH, EZ	
*	17	EH0122	O-Ring, P16 FKM	2	30, 35	VC, PC	EH, EZ
	EH0127	O-Ring, P16 EPDM	2	30, 35	VE, PE, VF	EH, EZ	
*	18	EH0027	O-Ring, S-14 FKM	1	30, 35	VC, PC	EH, EZ
	EH0050	O-Ring, S-14 EPDM	1	30, 35	VE, PE, VF	EH, EZ	
19	EH0407	Bolt, M4 x 36 SS Hex Socket	4	30	all	EH, EZ	
	EH0487	Bolt, M5 x 36 SS Hex Socket	4	35	all	EH	
	EH1347	Bolt, M5 x 35 SS Hex Socket	4	35	all	EZ	
23	EH1079	Knob, Manual Air Vent, PVC	1	30, 35	VC, VE, VF	EH, EZ	
	EH1089	Knob, Manual Air Vent, GFRPP	1	30, 35	PC, PE	EH, EZ	
*	27	EH1082	O-Ring, P-11 FKM	1	30, 35	VC, PC	EH, EZ
	EH1084	O-Ring, P-11, EPDM	1	30, 35	VE, PE, VF	EH, EZ	
ZZ	-----	Brass Spacers			Drive specific/Reuse when replacing diaphragm		
*		Included in spare parts kit					

PVDF Liquid End Exploded View #3

For all PVDF EH and EZ Pump Models

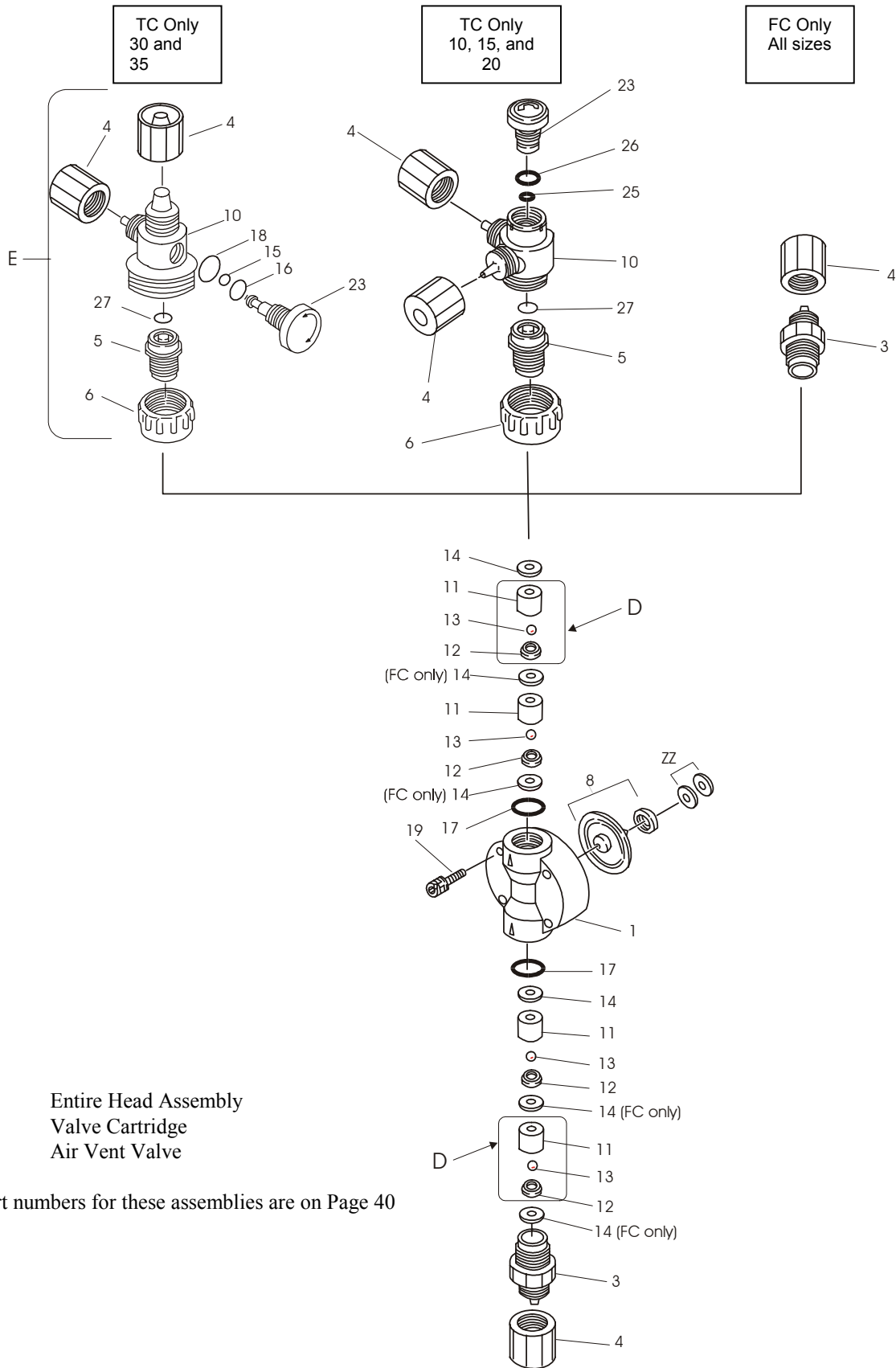

- C Entire Head Assembly
- D Valve Cartridge
- E Air Vent Valve

Part numbers for these assemblies are on Page 40

PVDF Liquid End Exploded View #3

Components

Item	Part No	Description	Qty	Size	Liquid End Mtl	Part No	Description	Qty	Size	Liquid End Mtl	
1	EH Heads					EZ Heads					
	EH0337	H10, PVDF	1	10	FC, TC	EH0608	Z10, PVDF	1	10	FC, TC	
	EH0814	H15, PVDF	1	15	FC, TC	EH0609	Z15, PVDF	1	15	FC, TC	
	EH0345	H20, PVDF	1	20	FC, TC	EH0610	Z20, PVDF	1	20	FC, TC	
	EH0349	H30, PVDF	1	30	FC, TC	EH0611	Z30, PVDF	1	30	FC, TC	
	EH0357	H35, PVDF	1	35	FC, TC	1142193600	Z35, PVDF	1	35	FC, TC	
Item	Part No	Description	Qty	Size	Liquid End Mtl	Series					
3	EH0425	Housing, Valve, 3/8 PVDF	2 / 1	10, 15, 20	FC / TC	EZ					
	EH0427	Housing, Valve, 1/2 PVDF	2 / 1	30, 35	FC / TC	EH, EZ					
4	EH0836	Nut, Coupling, 3/8 PVDF	2 / 3	10, 15, 20	FC / TC	EZ					
	EH0837	Nut, Coupling, 1/2 PVDF	2 / 3	30, 35	FC / TC	EH, EZ					
5	EH1051	Fitting, Air Vent, PVDF	1	10, 15, 20	TC	EH, EZ					
	EH1093	Fitting, Air Vent, PVDF	1	30, 35	TC	EH, EZ					
6	EH1047	Nut, Lock, Air Vent, PVDF	1	10, 15, 20	TC	EH, EZ					
	EH1092	Nut, Lock, Air Vent, PVDF	1	30, 35	TC	EH, EZ					
*	8	E90059	Diaphragm and retainer, H10	1	10	all	EH				
	E90064	Diaphragm and retainer, Z10	1	10	all	EZ					
	E90060	Diaphragm and retainer, H15	1	15	all	EH					
	E90065	Diaphragm and retainer, Z15	1	15	all	EZ					
	E90061	Diaphragm and retainer, H20	1	20	all	EH					
	E90066	Diaphragm and retainer, Z20	1	20	all	EZ					
	E90062	Diaphragm and retainer, H30	1	30	all	EH					
	E90067	Diaphragm and retainer, Z30	1	30	all	EZ					
	E90063	Diaphragm and retainer, H35	1	35	all	EH					
	E90490	Diaphragm and retainer, Z35	1	35	all	EZ					
10	EH1052	Body, Manual Air Vent, PVDF	1	10, 15, 20	TC	EH, EZ					
	EH1100	Body, Manual Air Vent, PVDF	1	30, 35	TC	EH, EZ					
*	11	EH0340	Guide, Valve, .188 PVDF	4	10	FC	EH, EZ				
	EH0346	Guide, Valve, .250 PVDF	4	15, 20	FC	EH, EZ					
	EH0612	Guide, Valve, .375 PVDF	4	30, 35	FC	EZ					
	EH0352	Guide, Valve, .375 PVDF	4	30, 35	FC, TC	EH, EZ (TC only)					
	EH1046	Guide, Valve, .188 PVDF	4	10	TC	EH, EZ					
	EH1050	Guide, Valve, .250 PVDF	4	15, 20	TC	EH, EZ					
*	12	EH0590	Seat, Valve, .188 PCTFE	4	10	FC	EH, EZ				
	EH0592	Seat, Valve, .250 PCTFE	4	15, 20	FC	EH, EZ					
	EH0593	Seat, Valve, .375 PCTFE	4	30, 35	FC	EH, EZ					
	EH0061	Seat, Valve, .188 FKM	4	10	TC	EH, EZ					
	EH0069	Seat, Valve, .250 FKM	4	15, 20	TC	EH, EZ					
	EH0119	Seat, Valve, .375 FKM	4	30, 35	TC	EH, EZ					
*	13	EH0025	Ball, Valve, .188 CE	4	10	FC, TC	EH, EZ				
	EH0084	Ball, Valve, .250 CE	4	15, 20	FC, TC	EH, EZ					
	EH0120	Ball, Valve, .375 CE	4	30, 35	FC, TC	EH, EZ					
*	14	EH0342	Gasket, Valve, .188 & .250 PTFE	6 / 2	10, 15, 20	FC / TC	EH, EZ				
	EH0354	Gasket, Valve, .375, PTFE	6 / 2	30, 35	FC / TC	EH, EZ					
15	EH1080	O-Ring, P-3, FKM	1	30, 35	TC	EH, EZ					
16	EH0029	O-Ring, P-6, FKM	1	30, 35	TC	EH, EZ					
*	17	EH0027	O-Ring, S-14, FKM	2	10, 15, 20	TC	EH, EZ				
	EH0122	O-Ring, P-16, FKM	2	30, 35	TC	EH, EZ					
	EH0591	Gasket, Vhousing, .188/.250 PTFE	2	10, 15, 20	FC	EH, EZ					
	EH0355	Gasket, Vhousing, .375 PTFE	2	30, 35	FC	EH					
	EH0613	Gasket, Vhousing, .375 PTFE	2	30, 35	FC	EZ					
*	18	EH0027	O-Ring, S-14, FKM	1	30, 35	TC	EH, EZ				
19	EH0742	Bolt, M4 x 33 SS Hex Socket	4	10, 15, 20	FC, TC	EH, EZ					
	EH0407	Bolt, M4 x 36 SS Hex Socket	4	30	FC, TC	EH, EZ					
	EH0487	Bolt, M5 x 36 SS Hex Socket	4	35	FC, TC	EH					
	EH1347	Bolt, M5 x 35 SS Hex Socket	4	35	FC, TC	EZ					
23	EH1049	Knob, Air Vent Valve	1	10, 15, 20	FC, TC	EH, EZ					
	EH1094	Knob, Air Vent, 1/2, PVDF	1	30, 35	FC, TC	EH, EZ					
*	25	EH0300	O-Ring, P-4, FKM	1	10, 15, 20	TC	EH, EZ				
*	26	EH0302	O-Ring, P-10A, FKM	1	10, 15, 20	TC	EH, EZ				
*	27	EH0304	O-Ring, P-7, FKM	1	10, 15, 20	TC	EH, EZ				
	EH1082	O-Ring, P-11, FKM	1	30, 35	TC	EH, EZ					
ZZ	-----	Brass spacers				Drive specific/Re-use when replacing diaphragm					
*	Included in spare parts kit										

S.S. Liquid End Exploded View #4

For all Stainless Steel (SH) EHB/C Pump Models

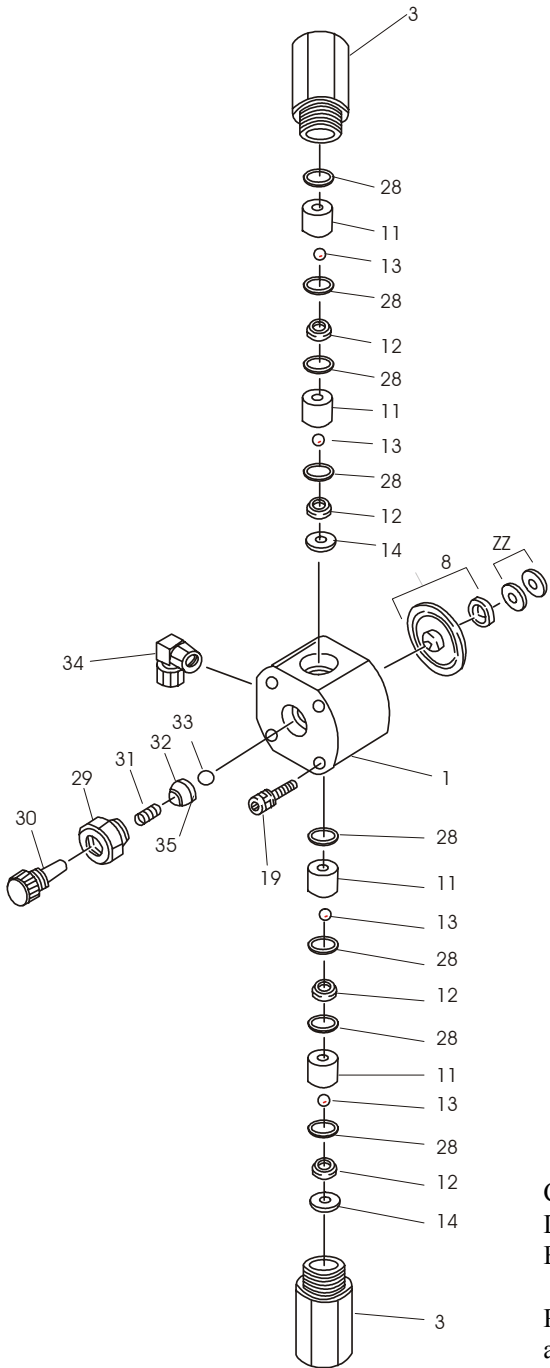

Item	Part No	Description	Qty	Size	
1	EH0358	Head, H10 SS	1	10	
	EH0372	Head, H20 SS	1	20	
	EH0376	Head, H30 SS	1	30	
	EH0383	Head, H35 SS	1	35	
3	EH0429	Housing, Valve, .188 & .250 SS	2	10, 20	
	EH0433	Housing, Valve, .375 1/4 NPTF SS	2	30, 35	
*	8	E90059	Diaphragm and retainer, H10	1	10
		E90061	Diaphragm and retainer, H20	1	20
		E90062	Diaphragm and retainer, H30	1	30
		E90063	Diaphragm and retainer, H35	1	35
* 11	EH0360	Guide, Valve, .188 SS	4	10	
	EH0373	Guide, Valve, .250 SS	4	20	
	EH0378	Guide, Valve, .375 SS	4	30, 35	
* 12	EH0587	Seat, Valve, .188 SS	4	10	
	EH0588	Seat, Valve, .250 SS	4	20	
	EH0589	Seat, Valve, .375 SS	4	30, 35	
* 13	EH0049	Ball, Valve, .188 HC	4	10	
	EH0072	Ball, Valve, .250 HC	4	20	
	EH0126	Ball, Valve, .375 HC	4	30, 35	
* 14	EH0362	Gasket, Valve Cartridge, PTFE	2	10, 20	
	EH0380	Gasket, Valve Cartridge, PTFE	2	30, 35	
19	EH1197	Bolt, M4 x 48.5 SS Hex Socket	4	10, 20, 30	
	EH1198	Bolt, M5 x 48.5 SS Hex Socket	4	35	
* 28	EH0365	Gasket, Valve, .188 & .250, PTFE	8	10, 20	
	EH0382	Gasket, Valve, .375 PTFE	8	30, 35	
29	EH0366	Nut, Seal, Air Vent SS	1	10, 20, 30, 35	
30	EH0367	Knob, Adjustment, Air Vent, SS	1	10, 20, 30, 35	
* 31	EH0368	Spring, Air Vent SS	1	10, 20, 30, 35	
* 32	EH0369	Seal Ring, Air Vent SS	1	10, 20, 30, 35	
* 33	EH0072	Ball, Valve, .250 HC	1	10, 20, 30, 35	
34	EH0431	Connector, Tubing, 3/8 PTFE	1	10, 20, 30, 35	
* 35	EH0371	Spacer, Air Vent, PCTFE	1	10, 20, 30, 35	
ZZ	-----	Brass Spacers		Drive specific/Re-use when replacing diaphragm	

* Included in spare parts kit

C Entire Head Assembly
D Valve Cartridge
E Air Vent Valve

Part numbers for these assemblies are on Page 40

Accessories (Not Shown)

Part No.	Description	Size	Liquid End Mtl	Series
E90001	Valve, Injection 3/8	10, 15, 20	VC	EH, EZ
E90002	Valve, Injection 3/8	10, 15, 20	VE, VF	EH, EZ
E90003	Valve, Injection, 3/8	10, 15, 20	PC	EH, EZ
E90004	Valve, Injection, 3/8	10, 15, 20	PE	EH, EZ
E90005	Valve, Injection 1/2	EHC30	VC	
E90006	Valve, Injection 1/2	EHC30	VE, VF	
E90007	Valve, Injection, 1/2	EZ30/35, EHB30, EHC35	VC	
E90008	Valve, Injection, 1/2	EZ30/35, EHB30, EHC35	VE, VF	
E90009	Valve, Injection, 1/2	EHC30	PC	
E90010	Valve, Injection, 1/2	EHC30	PE	
E90011	Valve, Injection, 1/2	EZ30/35, EHB30, EHC35	PC	
E90012	Valve, Injection, 1/2	EZ30/35, EHB30, EHC35	PE	
E90238	Valve, Injection, 3/8	10, 15, 20	TC	EH, EZ
E90020	Valve, Inj/Back Press, 3/8	10, 15, 20	FC	EH, EZ
E90022	Valve, Inj/Back Press, 1/2	30, 35	TC, FC	EH, EZ
E90013	Valve, Foot, 3/8	10, 15, 20	VC	EH, EZ
E90015	Valve, Foot, 3/8	10, 15, 20	PC	EH, EZ
E90016	Valve, Foot, 1/2	30, 35	VC	EH
E90018	Valve, Foot, 1/2	30, 35	PC	EH
E90034	Valve, Foot, 3/8	10, 15, 20	PE	EH, EZ
E90035	Valve, Foot, 3/8	10, 15, 20	VE	EH, EZ
E90036	Valve, Foot, 1/2	30, 35	PE	EH
E90037	Valve, Foot, 1/2	30, 35	VE	EH
E90193	Valve, Foot, 1/2	30, 35	VF	EH, EZ
E90234	Valve, Foot, 3/8	10, 15, 20	VF	EH, EZ
E90239	Valve, Foot, 1/2	30, 35	TC	EH, EZ
E90240	Valve, Foot, 3/8	10, 15, 20	TC	EH, EZ
E90241	Valve, Foot, 3/8	10, 15, 20	FC	EH, EZ
E90275	Valve, Foot, 1/2	30, 35	FC	EH, EZ
E00001-00	Tubing, 1/2 OD LLDPE per foot	30, 35	all	
E00001	Tubing, 1/2 OD LLDPE, 20 FT	30, 35	all	
E00001-50	Tubing, 1/2 OD LLDPE, 50 FT	30, 35	all	
E00001-100	Tubing, 1/2 OD LLDPE, 100 FT	30, 35	all	
E00001-250	Tubing, 1/2 OD LLDPE, 250 FT	30, 35	all	
E00001-500	Tubing, 1/2 OD LLDPE, 500 FT	30, 35	all	
E00002-00	Tubing, 3/8 OD LLDPE per foot	10, 15, 20	all	
E00002	Tubing, 3/8 OD LLDPE, 20 FT	10, 15, 20	all	
E00002-50	Tubing, 3/8 OD LLDPE, 50 FT	10, 15, 20	all	
E00002-100	Tubing, 3/8 OD LLDPE, 100 FT	10, 15, 20	all	
E00002-250	Tubing, 3/8 OD LLDPE, 250 FT	10, 15, 20	all	
E00002-500	Tubing, 3/8 OD LLDPE, 500 FT	10, 15, 20	all	
E00071	Weight, Ceramic	10, 15, 20, 30, 35	all	

Drive and Control Module Exploded View

B: R-CONTROL MODULE

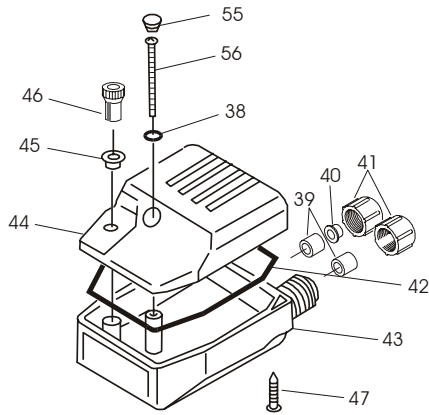

Y-CONTROL MODULE

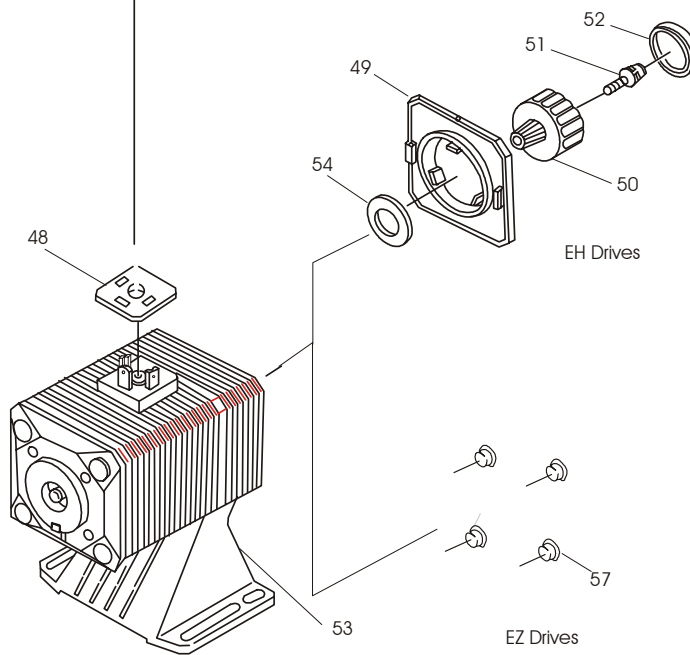
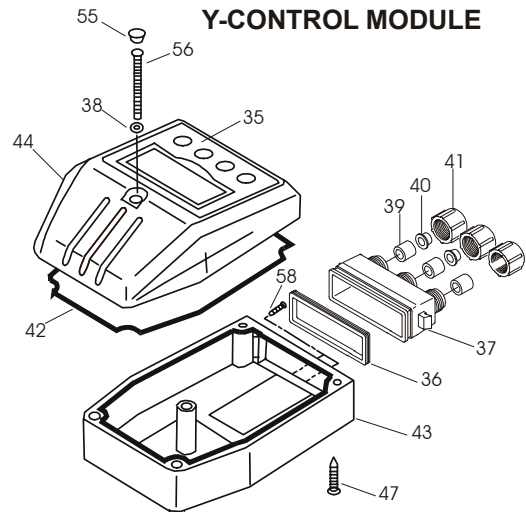

A: DRIVE UNIT

- A Drive Unit
- B R-Control Module
- Y-Control Module

Part numbers for these assemblies are on Page 40

Drive and Control Module Exploded View

Item	Part No.	Description	Series
35	EH1209	Label, Control Module Cover	EH-Y
36	EH1213	Gasket, Terminal Box	EH-Y
37	EH1212	Terminal Box	EH-Y
38	EH0261	Gasket, M3 x 35 Bolt	EH-R, EH-Y, EZ-D
39	EH0202	Grommet, Cord	EH-R, EH-Y, EZ-D
40	EH0204	Cap, Strain Relief	EH-R, EH-Y, EZ-D
41	EH0205	Nut, Strain Relief	EH-R, EH-Y, EZ-D
42	EH0271	Gasket, Control Module Case	EH-R
	EH1210	Gasket, Control Module Case	EH-Y
43	EH0505	Case, Control Module	EHB-R
	EH0507	Case, Control Module	EHC-R
	EH1211	Case, Control Module	EH-Y
44	EH0270	Cover, Control Module	EH-R
	EH1208	Cover, Control Module	EH-Y
45	EH0258	Seal, Stroke Frequency	EH-R,
46	EH0868	Knob, Stroke Frequency	EH-R
47	EH0269	Screw, Control Module	EH-R, EH-Y, EZ-D
48	EH0235	Gasket, Terminal Block	EH-R
	EH0547	Gasket, Terminal Block	EZ-D
49	EH0210	Cover, Stroke Adjust Dial	EHB
	EH0236	Cover, Stroke Adjust Dial	EHC
50	EH0280	Knob, Stroke Length Adjustment	EH
51	EH0211	Bolt, M4 x 25 SS	EH
52	EH0141	Cap, Stroke Length Adjustment	EH
53	EH0506	Base, Pump	EHB-R/EHB-Y
	EH0508	Base, Pump	EHC-R
	EH0508-Y	Base, Pump	EHC-Y
54	EH0268	Gasket, Stroke Adjustment	EH
55	EH0289	Plug, Control Module	EH, EZ
56	EH0241	Screw, M3 x 35 SS PH	EH, EZ
57	EH0549	Plug, Bolt	EZ
58	EH1205	Screw, Self Tap, Y-module	EH
	EH1438	Screw, Self Tap, D-module	EZ-D

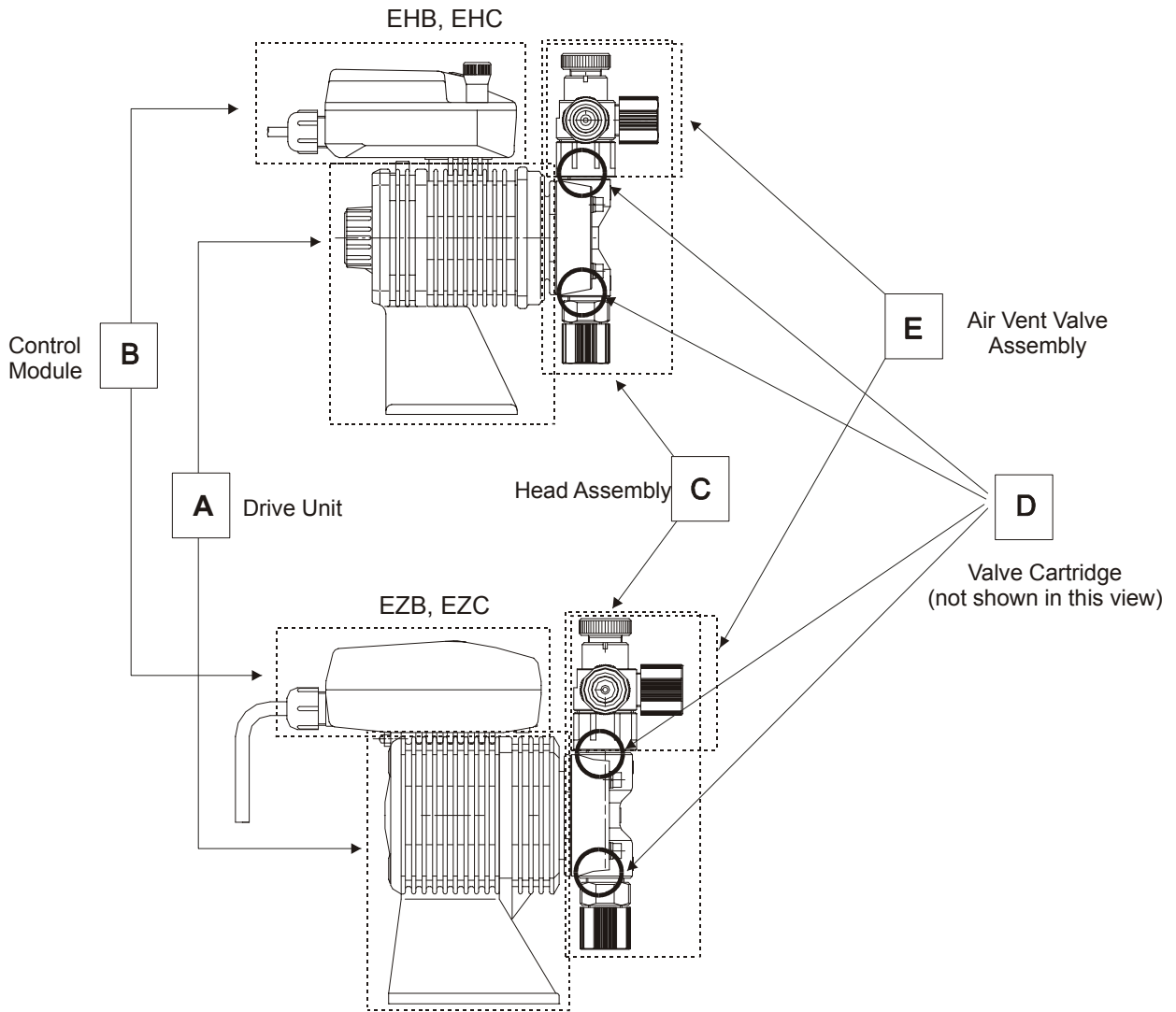

Key letters:

A	Drive Unit	D	Valve Cartridge
B	Control Module	E	Air Vent Valve Assembly
C	Head Assembly		

Notes:

“_” To get the correct model or part number, enter a “C” or “B” into the blank space

* The P/N in the block is the head assembly part number; For MFV head assemblies, add an “M” to the end of the part number.
The spare parts kit number is the same as the head assy # except with ‘-PK’ at the end; Parts kits for pumps with Multifunction valves are the same as pumps without the “M” option.

† For pump models using a “Y” Control Module, change the “R” in the model number to a “Y” to determine the correct Control Module part number. Add a “Y” to the end of the drive unit part number for pumps using a “Y” module.

Pump† Model	A Drive† Unit	B Control† Module	C Head Assembly/Spare Parts Kit* Liquid End Material							
			PC	PE	VC	VE	VF	TC	FC	SH
EHB10R1-	HB10-1	EHC-B11UPR	H10PC	H10PE	H10VC	H10VE	H10VF	H10TC	H10FC	H10SH
EHB10R2-	HB10-2	EHC-B23UPR								
EH__15R1-	H__15-1	EHC-__11UPR	H15PC	H15PE	H15VC	H15VE	H15VF	H15TC	H15FC	---
EH__15R2-	H__15-2	EHC-__23UPR								
EH__20R1-	H__20-1	EHC-__11UPR	H20PC	H20PE	H20VC	H20VE	H20VF	H20TC	H20FC	H20SH
EH__20R2-	H__20-2	EHC-__23UPR								
EH__30R1-	H__30-1	EHC-__11UPR-30	H30PC	H30PE	H30VC	H30VE	H30VF	H30TC	H30FC	H30SH
EH__30R2-	H__30-2	EHC-__23UPR-30								
EHC35R1-	HC35-1	EHC-C11UPR	H35PC	H35PE	H35VC	H35VE	H35VF	H35TC	H35FC	H35SH
EHC35R2-	HC35-2	EHC-C23UPR								
EZB10D1-	ZB10-D1	EZBD1	Z10PC	Z10PE	Z10VC	Z10VE	Z10VF	Z10TC	Z10FC	---
EZB10D2-	ZB10-D2	EZBD2								
EZ__15D1-	Z__15-D1	EZ__D1	Z15PC	Z15PE	Z15VC	Z15VE	Z15VF	Z15TC	Z15FC	---
EZ__15D2-	Z__15-D2	EZ__D2								
EZ__20D1-	Z__20-D1	EZ__D1	Z20PC	Z20PE	Z20VC	Z20VE	Z20VF	Z20TC	Z20FC	---
EZ__20D2-	Z__20-D2	EZ__D2								
EZ__30D1-	Z__30-D1	EZ__D1	Z30PC	Z30PE	Z30VC	Z30VE	Z30VF	Z30TC	Z30FC	---
EZ__30D2-	Z__30-D2	EZ__D2								
EZC35D1-	ZC35-D1	EZCD1	Z35PC	Z35PE	Z35VC	Z35VE	Z35VF	Z35TC	Z35FC	---
EZC35D2-	ZC35-D2	EZCD2								
D Valve Cartridge EH, EZ	10	E90041	E90042	E90038	E90039	E90302	E90305	E90044	---	
	15, 20	E90048	E90049	E90045	E90046	E90303	E90306	E90051	---	
	30, 35	E90055	E90056	E90052	E90053	E90304	E90307 (EH) E90309 (EZ)	E90058 (EH) E90441 (EZ)	---	
E Manual Air Vent Valve Assembly	10, 15, 20	E90026	E90027	E90024	E90025	E90025	E90308	---	---	
	30, 35	E90248	E90249	E90246	E90247	E90247	E90250	---	---	
Automatic Air Vent Valve	10, 15, 20	---	---	E90023	---	---	---	---	---	
MultiFunction Valve Assembly	10, 15, 20	E90364	E90365	E90362	E90363	E90363	---	---	---	

6.0 TROUBLESHOOTING

CAUTION: Before working on the pump, disconnect the power cord, depressurize the discharge tubing and drain or flush any residual liquid from the pump head and valves, using proper chemical handling techniques.

<u>Problem</u>	<u>Possible Cause</u>	<u>Corrective Action</u>
<i>Pump does not start</i>	Faulty wiring	Correct wiring
	Improper voltage	Connect to proper voltage source
	Electronic control unit is damaged	Replace control unit
<i>Pump does not prime</i>	Pump stroke length is too short	Operate pump with stroke length set at 100% until primed. Then set stroke length as needed to obtain desired output.
	Air in suction tubing	Reroute suction tubing to eliminate air trap
	Valve gasket is not installed	Install valve gasket
	Valve set assembly direction is wrong.	Reassemble valve set
	Pump is air locked	Open air vent valve
	Suction or discharge valve is clogged with foreign matter	Disassemble, inspect, clean
	Ball stuck to valve seat	Disassemble, inspect, clean

<u>Problem</u>	<u>Possible Cause</u>	<u>Corrective Action</u>
<i>Output fluctuates</i>	Suction or discharge valve is clogged with foreign matter	Disassemble, inspect, clean
	Air is trapped in pump	Open air vent valve
	Overfeeding	Install injection valve or back pressure valve
	Diaphragm is damaged	Replace diaphragm
<i>Liquid leaks</i>	Fitting or coupling nut is loose	Re-install (see section 2.3/2.4)
	Pump head is loose	Tighten pump head bolts Torque: 19 lb-in (2.16 N-m)
	Diaphragm is damaged	Replace diaphragm
	O-ring or valve gasket missing	Install o-ring or valve gasket

7.0 SERVICE POLICY

The EH and EZ Series electronic metering pumps have a 2-year warranty. Contact your Walchem distributor for service.

W A L C H E M

Five Boynton Road Hopping Brook Park Holliston, MA 01746 USA TEL 508-429-1110 FAX 508-429-7433

WEBSITE: www.walchem.com