



EW & EK Series Electronic Metering Pump Instruction Manual

W A L C H E M

Five Boynton Road Hopping Brook Park Holliston, MA 01746 USA TEL 508-429-1110 FAX 508-429-7433

WEBSITE: www.walchem.com

Notice

© 2007 WALCHEM Corporation
Five Boynton Road, Holliston, MA 01746 USA
tel (508) 429-1110 fax (508) 429-7433
All Rights Reserved
Printed in USA

Proprietary Material

The information and descriptions contained herein are the property of WALCHEM Corporation. Such information and descriptions may not be copied or reproduced by any means, or disseminated or distributed without the express prior written permission of WALCHEM Corporation.

This document is for information purposes only and is subject to change without notice.

Statement of Limited Warranty

WALCHEM Corporation warrants equipment of its manufacture and bearing its identification to be free from defects in workmanship and material for a period of two years from date of delivery from the factory or authorized distributor under normal use and service and otherwise when such equipment is used in accordance with instructions furnished by WALCHEM Corporation and for the purposes disclosed in writing at the time purchased, if any. WALCHEM Corporation's liability under this warranty shall be limited to replacement or repair, F.O.B. Holliston, MA U.S.A. of any defective equipment or part which, having been returned to WALCHEM Corporation, transportation charges prepaid, has been inspected and determined by WALCHEM Corporation to be defective.

THIS WARRANTY IS IN LIEU OF ANY OTHER WARRANTY, EITHER EXPRESS OR IMPLIED, AS TO DESCRIPTION, QUALITY, MERCHANT-ABILITY, FITNESS FOR ANY PARTICULAR PURPOSE OR USE, OR ANY OTHER MATTER.

*P/N E00118.D
March 2007*

TABLE OF CONTENTS

Thank you for choosing a Walchem E-Class metering pump. This instruction manual deals with the correct installation, operation, maintenance and troubleshooting procedures for the EW and EK model metering pumps. Please read through it carefully to ensure the optimum performance, safety and service of your pump.

1.0	INTRODUCTION	1
1.1	Safety and Caution Notes	1
1.2	Principle of Operation	1
1.3	Model Code	2
1.4	Specifications	3
1.5	Dimensions.....	4
2.0	INSTALLATION	6
2.1	Unpacking	6
2.2	Location.....	6
2.3	Supply Tubing.....	7
2.4	Discharge Tubing	8
2.5	Installing Injection/BackPressure Valve	9
2.6	Electrical.....	9
3.0	OPERATION	10
3.1	Pump Operation & Programming	10
3.2	External Inputs & Outputs	12
3.3	Adjustment	14
3.4	MultiFunction Valve Operation	15
3.5	Auto Air Vent Valve Operation	16
3.6	Priming	17
3.7	Calibration	17
3.8	AC Power Interruption	17
4.0	MAINTENANCE	18
4.1	Diaphragm Replacement	18
4.2	Valve Replacement	18
4.3	Tubing	18
5.0	EXPLODED VIEW & PARTS GUIDE	19
6.0	TROUBLESHOOTING	26
7.0	SERVICE POLICY	27

1.0 INTRODUCTION

1.1 Safety and Caution Notes



Always wear protective clothing, eye protection and gloves before working on or near a metering pump. Follow all recommendations of the supplier of the solution being pumped. Refer to the MSDS from the solution supplier for additional precautions.

Walchem E-Class metering pumps should be installed where ambient temperatures do not exceed 122°F (50°C) or do not fall below 32°F (0°C), or where pump or tubing are directly exposed to sunlight.



WARNING Risk of electrical shock! This pump is supplied with a grounding conductor and grounding-type attachment plug. To reduce the risk of electrical shock, be certain that it is connected only to a properly grounded, grounding type receptacle with ratings conforming to the data on the pump data plate. Prior to performing any maintenance on a pump, disconnect the pump from the electrical power source.



Plumbing Precautions

All tubing must be securely attached to the fittings prior to starting the pump (see Section 2.3). Only use Walchem tubing with your pump. Tubing should be shielded to prevent possible injury in case of rupture or damage. UV resistant tubing should be used if the tubing is exposed to UV light. Always adhere to local plumbing codes and requirements. Be sure that the installation does not constitute a cross connection. Walchem is not responsible for improper installations. Prior to performing any maintenance on a pump, depressurize the discharge tubing.

If you are pumping downhill or into little or no system pressure, a back pressure/anti-siphon device must be installed to prevent over-pumping. Contact your Walchem distributor for additional information.



Solution Compatibility

CAUTION! This pump has been evaluated for use with water only. The suitability of this pump for use with liquids other than water, such as acid and alkaline, is the responsibility of the user. For liquids other than water, select the best-suited liquid end material combination using a chemical compatibility chart.

1.2 Principle of Operation

The E-Class electronic metering pumps consist of a pump unit, a drive unit, and a control unit. The drive unit is an electromagnetic solenoid. When the solenoid coil is energized by the control unit the armature shaft moves forward due to the magnetic force of the solenoid. The shaft is attached to a PTFE faced diaphragm which is part of the pump unit. The diaphragm is forced into the pump head cavity decreasing volume and increasing pressure which forces liquid in the pump head out through the discharge check valves. When the solenoid coil is de-energized, a spring returns the armature to its starting position. This action pulls the diaphragm out of the head cavity increasing volume and decreasing pressure. Atmospheric pressure then pushes liquid from the supply tank through the suction check valves to refill the pump head.

1.3 Model Code

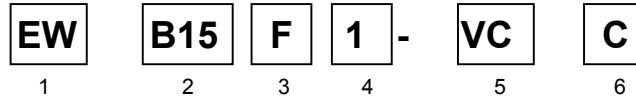

1 Pump Series

EW IP 65 electronic metering pump with external pulse control or manual speed control (adjustable to 360 strokes per minute) and manually adjustable stroke length. (Turndown ratio 1800:1.)

EK IP 67 aggressive environment rated electronic metering pump with external pulse control or manual speed control (adjustable to 360 strokes per minute) and manually adjustable stroke length. (Turndown ratio 1800:1.)

2 Capacity/Pressure Rating (See Section 1.4 for detailed chart.)

3 Control Module

F For use on all EW models, features digitally adjustable speed and external pulse input control, stop & pre-stop inputs

R For use on all EK models, features external pulse input control and stop input.

4 Voltage

1 115 VAC, 50/60 Hz

2 230 VAC, 50/60 Hz

5 Liquid End (See Section 1.4 for detailed chart.)

6 Options

C High Compression Configuration: Supplied standard with Auto Air Vent Valve in place of manual air vent valve. Available for B10, B15, C15 and C20 sizes with -VC liquid ends only.

M Multifunction Valve is supplied in place of the manual air vent valve. Available for the EW and EK 10-20 sized pumps with VC, VE, VF, PC, and PE liquid ends. Not available with the AAVV feature.

1.4 Specifications

Electrical	50/60 Hz, single phase		
EWB/EKB	115 VAC±10%	0.8 Amp max.	20 watt avg.
	230 VAC±10%	0.4 Amp max.	20 watt avg.
EWC/EKC	115 VAC±10%	1.2 Amp max.	22 watt avg.
	230 VAC±10%	0.6 Amp max.	22 watt avg.

Operating Conditions

Ambient temperature	32°F to 122°F (0°C to 50°C)
Relative humidity	To 85% (EW) / 95% (EK) non-condensing
Liquid temperature	32° to 104°F (0 to 40°C) for PVC based liquid ends
	32° to 140°F (0 to 60°C) for PP, PVDF, SS based liquid ends
	Below 32°F (0°C), pump is limited to 70% of max. pressure. Liquid cannot freeze.

Capacity/Pressure Rating

Size	Maximum Output Capacity		Output per Stroke (mL)		Maximum Pressure ¹		Connection Size (in) Tubing O.D
	(Gal/hr)	(mL/min)	Min.	Max.	PSI	MPa	
B10	0.6	38	0.03	0.11	150	1.0	3/8
B15	1.0	65	0.04	0.18	105	0.7	3/8
B20	1.8	115	0.07	0.32	60	0.4	3/8
B30	3.3	210	0.12	0.58	30	0.2	1/2
C15	1.3	80	0.05	0.22	150	1.0	3/8
C20	2.3	145	0.08	0.40	105	0.7	3/8
C30	4.3	270	0.15	0.75	50	0.35	1/2
C35²	6.7	420	0.24	1.17	30	0.2	1/2

¹ Auto Air vent valve reduces maximum pressure approx. 35 PSI (0.2 MPa)

² Output of the EW/EKC35-TC/FC/SH is 6.3 GPH (400 ml/min)

Adjustment Range

Stroke length adjustment range	20% to 100%
Frequency adjustment range	0 to 360 strokes per minute

Materials of Construction

Liquid End Code	Pump Head & Fittings	Diaphragm	Valve Balls	Valve Seat	Valve Seals	Gasket	Tubing
PC	GFRPP	PTFE (bonded to EPDM)	CE	FKM	FKM	PTFE	PE
PE	GFRPP		CE	EPDM	EPDM		
VC	PVC		CE	FKM	FKM		
VE	PVC		CE	EPDM	EPDM		
VF	PVC		PTFE	EPDM	EPDM		
TC	PVDF		CE	FKM	FKM		
FC	PVDF		CE	PCTFE	PTFE		
SH	SS		HC	HC	PTFE		

CE	Alumina ceramic	PE	Polyethylene
EPDM	Ethylene propylene diene monomer	PTFE	Polytetrafluoroethylene
FKM	Fluoroelastomer	PVC	Polyvinylchloride (translucent)
GFRPP	Glass fiber reinforced polypropylene	PVDF	Polyvinylidene fluoride
HC	Hastelloy C276	SS	316 stainless steel
PCTFE	Polychlorotrifluoroethylene		

1.5 Dimensions

EW-10,15 and 20 Models with thermoplastic liquid end materials

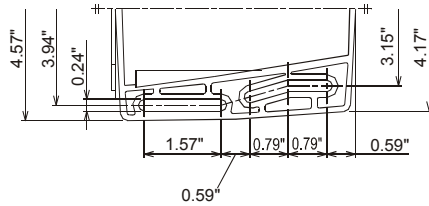
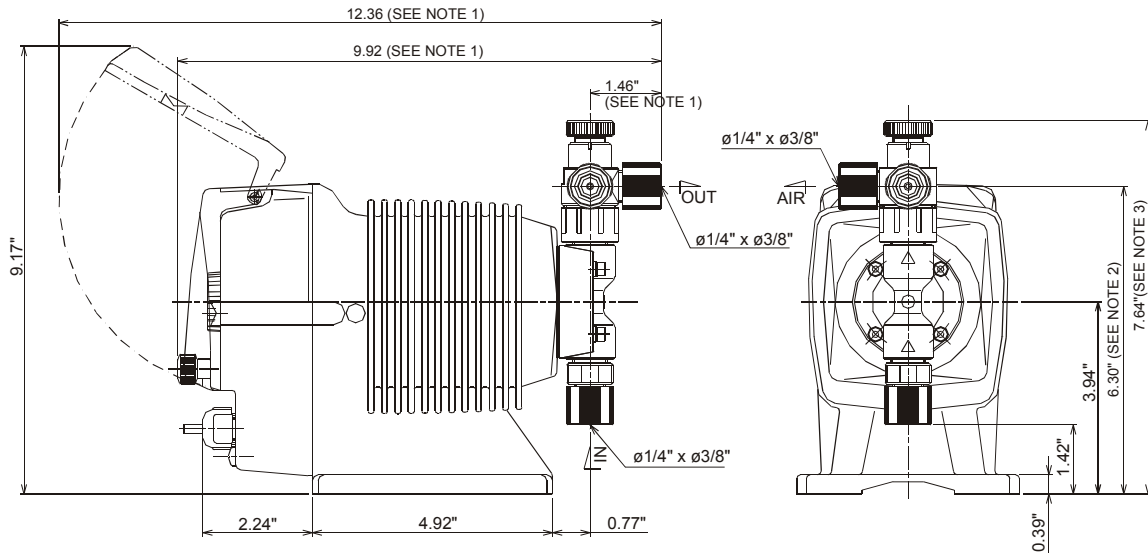

Notes:

1. Addition of a Multifunction valve increases overall length by 0.37". Addition of an Auto Air Vent Valve increases overall length by 1.59"
2. Addition of a Multifunction Valve increases discharge height by 0.22". No change for the Auto Air Vent Valve.
3. Addition of a Multifunction Valve increases overall liquid end height by 1.16". No change for the Auto Air Vent Valve.
4. All dimensions in inches.

EW-30 and 35 Models with thermoplastic liquid ends

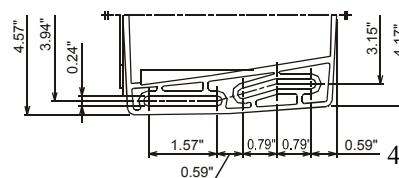
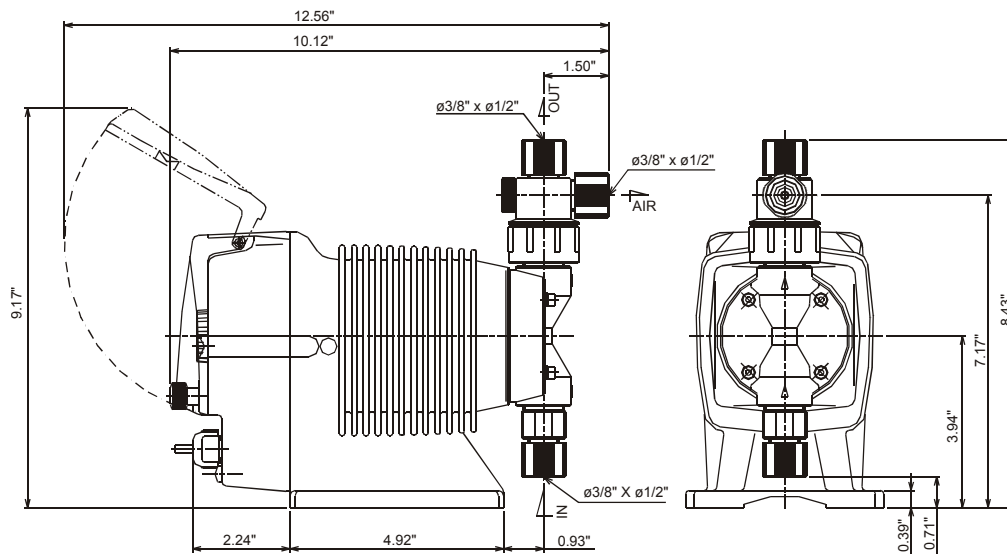

Notes:

1. All dimensions in inches.

EK-10,15 and 20 Models with thermoplastic liquid end materials

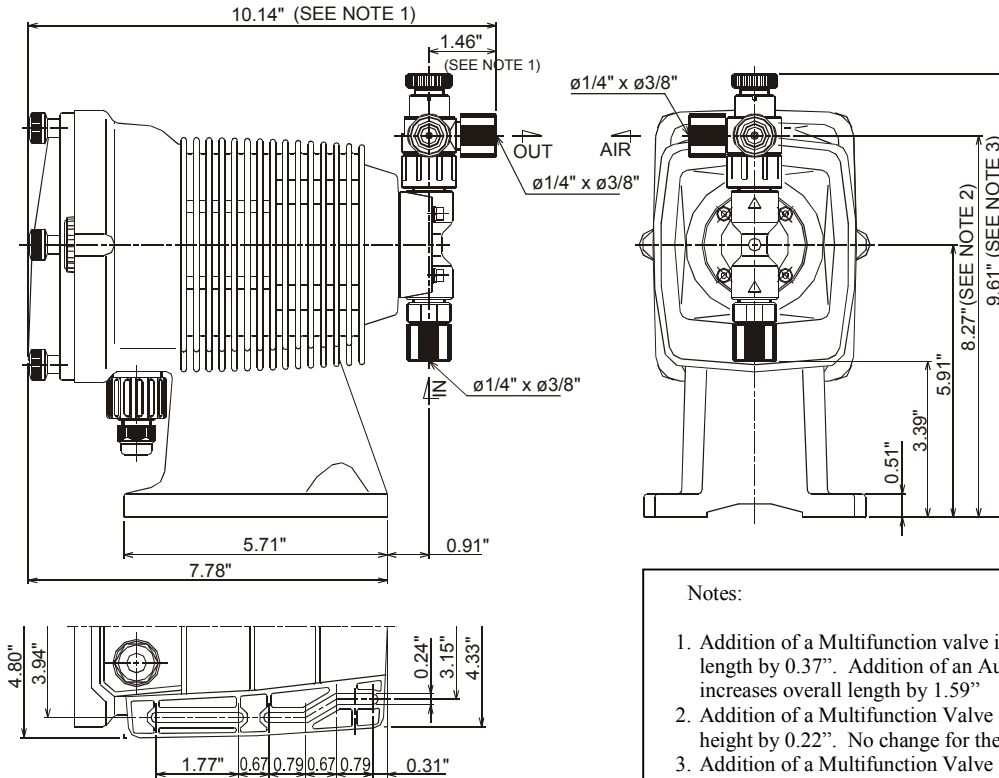

- Notes:
1. Addition of a Multifunction valve increases overall length by 0.37". Addition of an Auto Air Vent Valve increases overall length by 1.59"
 2. Addition of a Multifunction Valve increases discharge height by 0.22". No change for the Auto Air Vent Valve.
 3. Addition of a Multifunction Valve increases overall liquid end height by 1.16". No change for the Auto Air Vent Valve.
 4. All dimensions in inches.

EK-30 and 35 Models with thermoplastic liquid ends

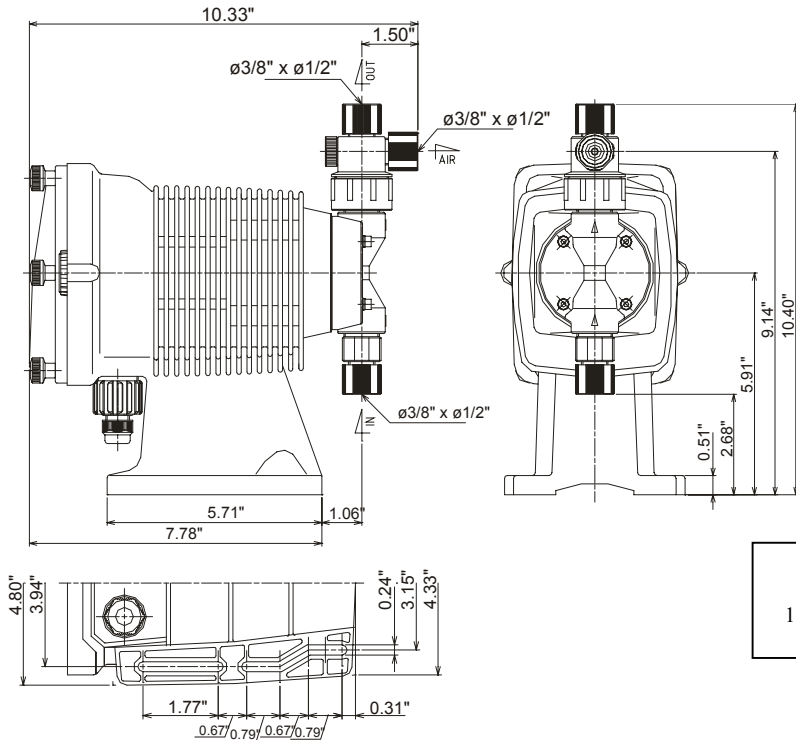

- Notes:
1. All dimensions in inches.

2.0 INSTALLATION

2.1 Unpacking

Open the shipping carton and inspect contents for damage. If any items are missing or damaged contact your local distributor.



Pumps are pre-primed with water at the factory. If the application is not compatible with water, drain and dry before use. Be sure to remove caps from fittings before attaching tubing.

CAUTION: Head bolts may have loosened during storage or shipment. Be sure to check and tighten to 19 lb-in torque, if necessary.

2.2 Location

Choose a location for the pump which is clean, dry, close to an electrical outlet, and allows convenient access to stroke length control, frequency control, and tubing connections. Avoid areas where ambient temperature exceeds 122°F (50°C) or falls below 32°F (0°C), or where the pump or tubing would be exposed to direct sunlight.

This pump is cord connected and not intended for permanent mounting to a building structure. However, temporary mounting to stabilize the pump during operation may be necessary as long as tools are not required for the installation or removal of the pump.

Flooded suction (mounting the pump below the level of liquid in the supply tank) is strongly recommended, especially when pumping liquids that readily generate gas bubbles. Sodium hypochlorite and hydrogen peroxide are common examples of such liquids. (See Figure 1.)

If flooded suction mounting is not possible, a shelf adjacent to (but not directly above) the supply tank often works well. (See Figure 2.) The supply tank or cover can also be used if it has provisions for mounting a pump. (See Figure 3.) In any case, the total suction lift should not exceed 5 ft (1.5m).

Figure 1
Flooded Suction
Recommended for
liquids that out-gas

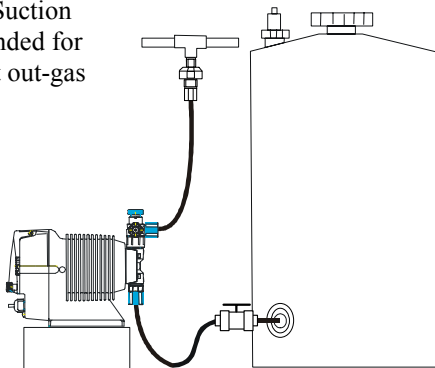

Figure 2
Shelf Mount

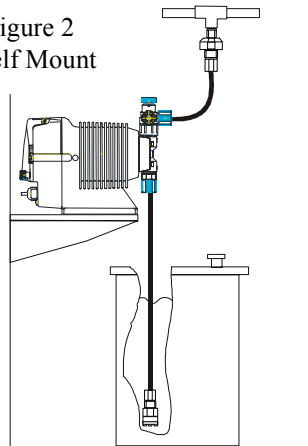
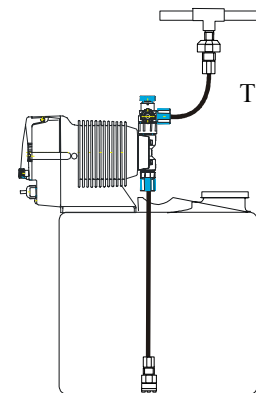

Figure 3
Tank Mount



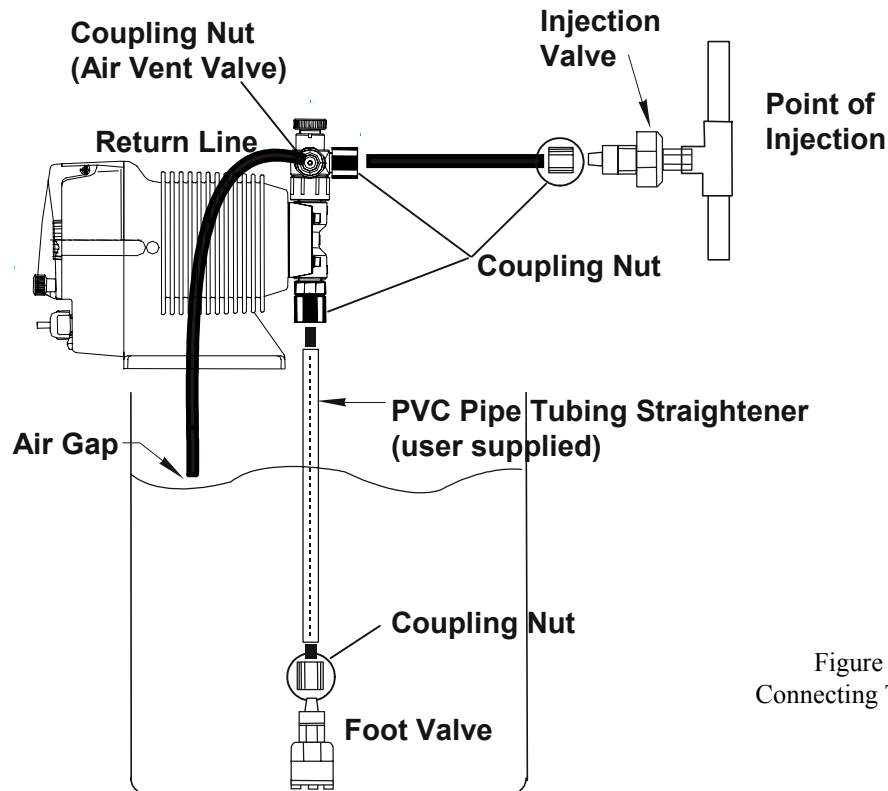

Figure 4
Connecting Tubing

2.3 Supply Tubing

The supply tubing run should be as short as possible. For flooded suction mounting, install a shut-off valve with an appropriate tubing connector at the tank outlet. Cut a length of tubing from the coil supplied and install between the shut-off valve and the pump inlet fitting. For suction lift applications, slide on the ceramic weight, then install a foot valve on one end of suction tubing. Cut the tubing to a length such that the foot valve hangs vertically about 1 in (25mm) above the bottom of the tank. Avoid any loops in the tubing run that could form a vapor trap. Running the tubing through a length of pipe will help to keep tubing straight. Total vertical suction lift should be no more than 5ft. (1.5m). Reference Figure 4.

Attach tubing as shown in Figure 5. First slide the coupling nut, small end first, onto the tubing. Push the tubing over the valve housing tip *all the way to the valve housing shoulder*. (Tip: if the tubing is stiff from cold, dip the tubing end in hot tap water for a few minutes so it will slide on and flare out more easily. Push the coupling nut onto the threads. Apply some pressure on the coupling nut and tubing while tightening the nut, making sure the tubing has not backed off of the shoulder of the valve housing.



WARNING: All fittings and coupling nuts should be tightened by hand only. If necessary, a small tool may be used to make it snug. DO NOT use excessive force or large wrenches.

The coupling nut should not bottom out completely against the fitting. If this happens during connection, either the tubing has slid down the shoulder while tightening, or the tubing has been pinched. Remove the coupling nut, re-cut the tubing and re-connect.



WARNING: *If there is any leakage around the coupling nut and it appears to have been installed correctly, DO NOT TIGHTEN the coupling further! Release pressure in the line, disconnect tubing, re-cut and re-connect. Tightening of misinstalled tubing may cause the tubing to pop off under pressure.*

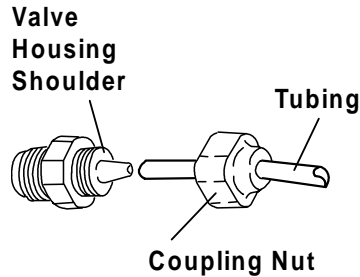

Figure 5
Attaching the Tubing

2.4 Discharge Tubing

Cut a length of tubing long enough to go from the pump to the application (injection) point. Additional tubing can be ordered from your distributor. Avoid sharp turns or bends and hot surfaces. Routing tubing through rigid pipe such as PVC pipe is recommended for long runs and/or as protective shielding against corrosive chemicals. If applicable, install the injection valve in 1/2" NPT thread at the injection point (see section 2.5) and connect the discharge tubing to the injection valve.

Attach tubing as described in section 2.3 and as shown in Figures 5 and 6. Note: Some models have an air vent valve with two outlet connections. The connection marked 'OUT' is the discharge side to the application point. (Fig 6).

Attach a second length of tubing to the air vent side marked ('AIR') and route back to the chemical solution tank or drum. On the larger pumps (30 & 35 sizes), the air vent valve connections are not marked, however, the discharge side is the vertical (UP) connection and the air vent connection is on the side of the valve.

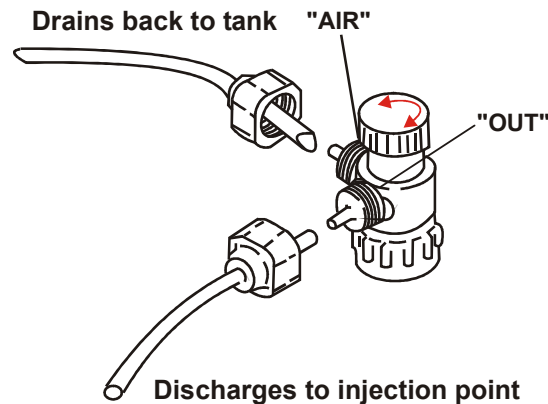

Figure 6
Air Vent Valve Tubing

2.5 Installing Injection/BackPressure Valve

A fitting or tee with 1/2" NPTF threads and with sufficient depth will accept the injection valve assembly. If required, trim off an amount of the extension tip until it fits your fitting or tee. (Fig. 7.)

The position of the injection/back pressure valve can be at any orientation as long as the spring is retained in the valve. **DO NOT REMOVE THE SPRING.** Be sure to check and replace the spring as needed. Attach the tubing following the same instructions in section 2.3, connecting the supply tubing.

CAUTION: Some chemicals may have reactions as they are injected into the main flow. For example, sulfuric acid may react with water causing excess heat. If the chemical is heavier than water, mount the injection valve as close as possible to vertical coming into the bottom of the pipe. This will keep the injection nozzle facing up and keep the heavier chemistry from draining into the pipe and causing adverse reactions within the injection valve and pipe.

In addition to preventing backflow from pressurized lines, the injection valve acts somewhat as a back pressure valve when pumping into open atmosphere type applications. However, the back pressure by the injection valve is very low and can vary. The output of the metering pumps is rated at maximum back pressure and will increase as back pressure decreases dependent on the specific installation. Additionally, the valve does NOT act as an anti-siphon valve. If siphoning is a possibility, or if pumping downhill into open atmosphere (open tank), a Walchem MultiFunction valve or a separate back pressure/anti-siphon valve must be installed.

Note: Siphoning can also occur at the tip of the injection valve because of the high flow rate in the main pipe flowing past the small injection nozzle (venturi effect). In this case, an anti-siphon device must be installed to avoid over feeding or siphoning of chemistry.

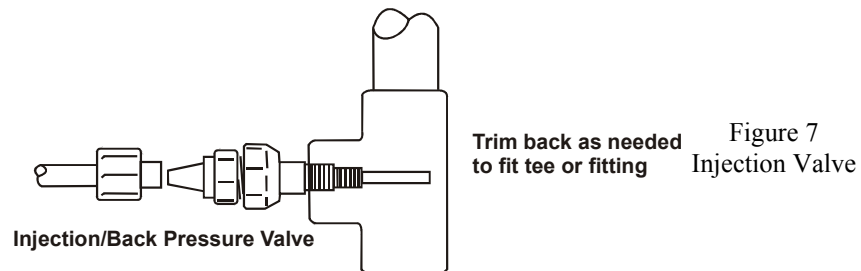

2.6 Electrical



WARNING Risk of electrical shock! *This pump is supplied with a grounding conductor and grounding-type attachment plug. To reduce the risk of electrical shock, be certain that it is connected only to a properly grounded, grounding type receptacle.*

CAUTION! The electronics within the pump can be damaged by excessive surges in voltage. Do not install the pump near high-power electrical equipment that generate high surge voltages. Avoid branch circuits that also supply power to heavy or other equipment that could generate electrical interference. If necessary, install a surge suppression device (such as a varistor with a resistance greater than 2000A) or a noise reducing transformer at the pump's power connection.

3.0 OPERATION

3.1 Pump Operation & Programming

The EW an EK pumps have a digital display, two LED indicators and three pushbutton keys to change the pump speed and programming.

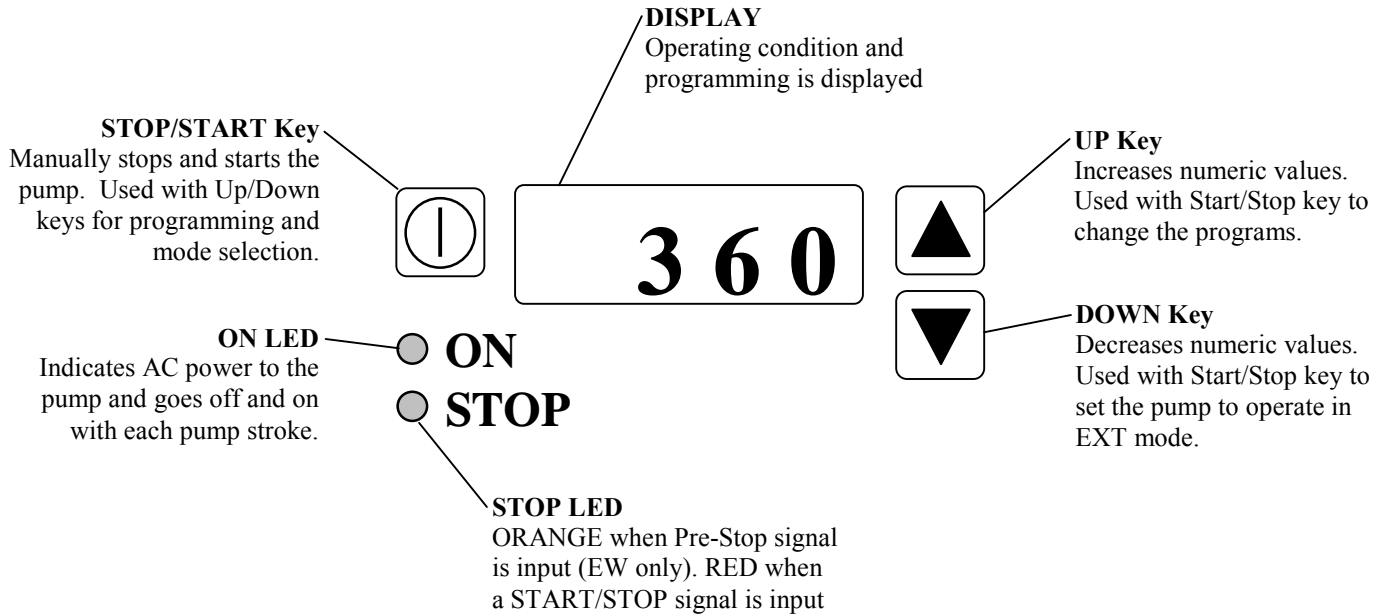

A. Operation Overview

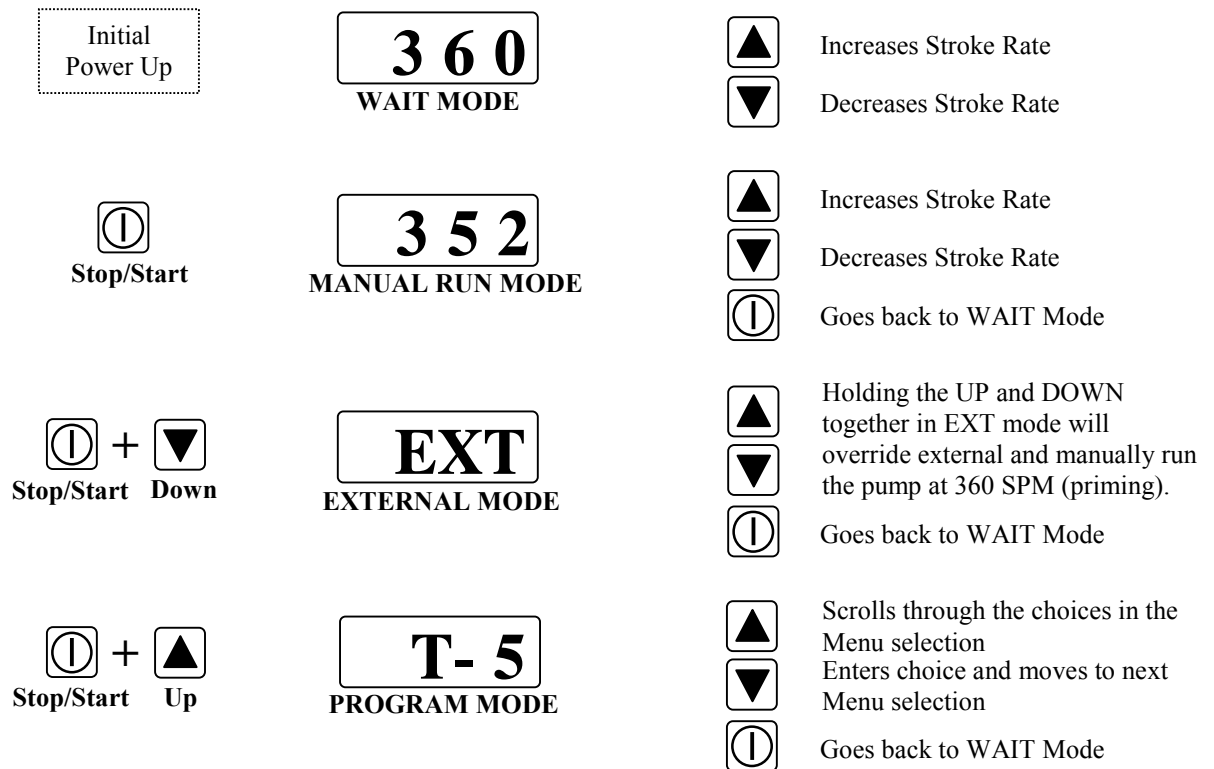

B. Programming

Pressing the stop/start and up keys simultaneously will enter the program mode. The up and down keys scroll through the menus and choices and the stop/start key will exit back to the wait mode.

The first item displayed will be the factory set choice of the External Input On-Time menu (T-5). There are three choices in this menu: T-5, T-20, and T-50 that can be scrolled through by repeatedly pressing the up key. These settings are time in milliseconds and correlate to the required minimum closure time of the external input signal for the pump to recognize it as a true signal. Selecting the smaller T-5 (5 msec) will allow shorter duration pulses to be recognized (typical for Hall Effect input), while the T-50 (50 msec) setting will help to reduce erroneous pulses from noise (as from a reed switch).

Pressing the down key will move from the External Input On-Time menu to the Stop menu and the initial factory setting is M-OFF (input is normally open and contact closure will stop the pump). Pressing the up key will toggle between M-OFF and M-ON. Setting the pump to M-ON means that the pump will be stopped continuously and a contact closure into the stop/start input will now start the pump and the pump will run as long as the contact is made.

Pressing the down key will again move back to the On-Time menu and pressing the stop/start key will go back to the wait mode.

C. Pump Operation

Manual and On/Off Control

The pumps can be operated manually by pressing the stop/start key from the wait mode. Once pressed, the pump will begin to operate at the stroke rate shown on the display. From here, the up and down keys can be used to change the stroke rate, and the stroke length knob can be adjusted down to further reduce the pump output.

Once adjusted/calibrated to the desired flow rate, the pump can be left in manual mode for on/off control via power (connecting/disconnecting AC power from an external source) or for on/off control via the stop/start input. Pressing the stop/start key will go back to the wait mode.

External Control

Pressing the stop/start key and the down key simultaneously from the wait mode will set the pump to operate in external mode. In this mode, the pump will operate at a speed correlating to the frequency of digital inputs that it receives (see section 3.2 for wiring inputs). If used, the stop/start input will override the digital input signals.

If at any time in external mode the up and down keys are held down simultaneously, the pump will manually run at 360 SPM as long as the two keys are held down. This feature is useful for priming or the elimination of air trapped in the pump or tubing.

Pressing the stop/start key will disable external control and go back to the wait mode.

3.2 External Inputs & Outputs

The EW and EK pumps are capable of being controlled by an external pulse proportional input as well as being controlled by an external stop/start signal. Additionally, the EW pumps have two contact closure relay outputs – one output is synchronous with the pump frequency and the other is tied to the external stop/start signal.

A. EW Pumps and the ‘F’ control module

Two circular mini-DIN female connectors are used to make these connections. See Figure 9. Connector 1 is a 5-PIN standard-key connector (P/N E90495) and Connector 2 is a 4-PIN reverse-key connector (P/N E90494).

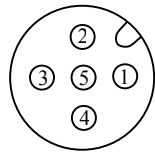

Connector 1

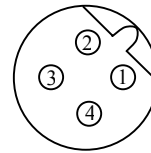

Connector 2

<u>PIN</u>	<u>FUNCTION</u>
1	Voltage In (24VDC max)
2	External Digital Input
3	Out 2 (Synchronous with stroke)
4	Out 1 (Stop output)
5	Common

<u>PIN</u>	<u>FUNCTION</u>
1	Stop/Start Input
2	Pre-Stop Input
3	Not Used
4	Common

Figure 9

External Control

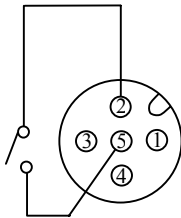

The external pulse input should not exceed 360 pulses per minute (6Hz) and the pump will output one stroke for every input pulse. The control signal can be a contact closure type switch (reed) with a max load of 1mA or a solid state device. If a solid state device is used, the external circuit should be capable of switching 5VDC at 1.2mA with an active duty cycle pulse width of 5ms to 100ms (actual closure time).

To connect the pulse input from an external device, wire PINs 2 and 5 from the contact closure. If using a solid state switching device, wire the connector ensuring that PIN 2 is positive (+) and PIN 5 is Common (-).

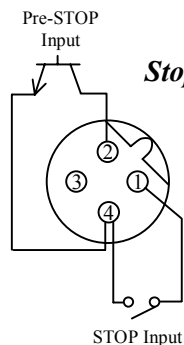

Stop/Start and Pre-Stop Control

The EW pumps have two stop inputs. The Pre-Stop is an external input that changes the green STOP LED to orange to signal a “LOW” condition. This input does not control the pump. An external Stop/Start signal, however, not only turns the STOP LED to red, but also controls the pump. In this mode, AC power is applied continuously, but the pump operation is stopped (or started – see section on programming) by completing the circuit between PIN 1 and PIN 4 in Connector 2. Both the Pre-Stop and Stop/Start signals can be a contact closure type switch (reed) with a max load of 1mA or a solid state device. If a solid state device is used, the external circuit should be capable of switching 5VDC at 1.2mA with an active duty cycle pulse width of 5ms to 100ms (actual closure time).

To connect the Pre-Stop input from an external device, wire PINs 2 and 4 from the contact closure. If using a solid state switching device, wire the connector ensuring that PIN 2 is positive (+) and PIN 4 is Common (-).

To connect the Stop/Start input from an external device, wire PINs 1 and 4 from the contact closure. If using a solid state switching device, wire the connector ensuring that PIN 1 is positive (+) and PIN 4 is Common (-).

Output Relays

The EW pumps have two output relays (non-isolated PNP transistors with a 330Ω resistance) in Connector 1. Output 1 is tied to the Stop/Start input and will activate when a Stop/Start input connection is made. Output 2 activates synchronously with the pump stroke rate.

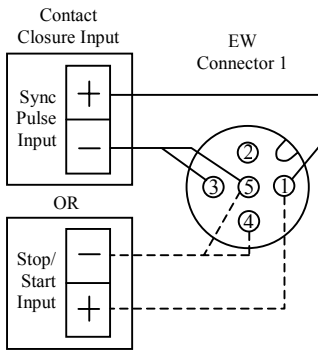

Contact Closure Type Outputs:

The EW circuit can make either the Stop/Start (Out 1) or the synchronous pulse (Out 2) function as contact closures, but ONLY ONE output can be used at a time. To use the synchronous pulse out, connect the positive side to PIN 1 and the negative side to PINS 3&5 (jumped together). To use the start/stop output, connect the positive side to PIN 1 and the negative side to PINS 4&5 (jumped together).

Voltage Input Type Outputs (Non-Contact Closure)

PIN 1 will take a voltage in from an external source (max 24VDC). When this external voltage is present, then both relays will independently switch the input voltage. Both outputs can be used simultaneously. The figure to the left shows a schematic with the output relays configured to switch the powered input. This setup can only be used with voltage input type circuits (not contact closure types) such as those commonly found in a PLC.

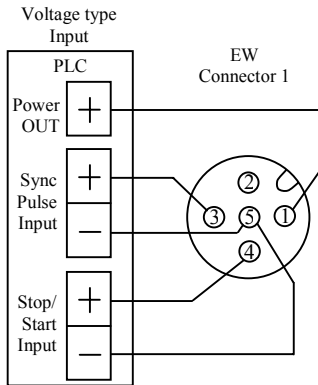

B. EK Pumps and the 'R' control module

One custom watertight connector is used for the digital input and stop/start connections on the EK pumps. There are no outputs on the EK pumps. The Connector Holder is keyed to fit into the pump only one direction. There is a set of painted alignment marks on the connector and connector holder that identify the correct orientation of the connector. Be sure to double check that the connector is installed properly into the connector assembly before installation onto the pump.

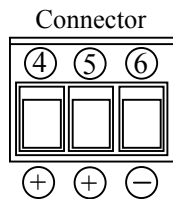

PIN	FUNCTION
4	External Digital Input
5	Stop/Start Input
6	Common

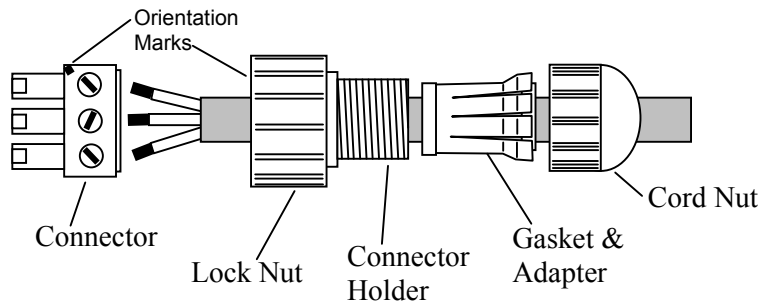

Digital Control

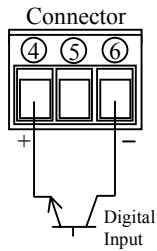

The external pulse input should not exceed 360 pulses per minute (6Hz) and the pump will output one stroke for every input pulse. The control signal can be a contact closure type switch (reed) with a max load of 1mA or a solid state device. If a solid state device is used, the external circuit should be capable of switching 5VDC at 1.2mA with an active duty cycle pulse width of 5ms to 100ms (actual closure time).

To connect the pulse input from an external device, wire Terminal 4 and Terminal 5 from the contact closure. If using a solid state switching device, wire the connector ensuring that Terminal 2 is positive (+) and Terminal 5 is Common (-).

Stop/Start Control

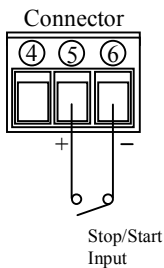

An external Stop/Start signal will turn the STOP LED to red and also control the pump. In this mode, AC power is applied continuously, but the pump operation is stopped (or started – see section on programming) by completing the circuit between Terminal 5 and Terminal 6. The Stop/Start signal can be a contact closure type switch (reed) with a max load of 1mA or a solid state device. If a solid state device is used, the external circuit should be capable of switching 5VDC at 1.2mA with an active duty cycle pulse width of 5ms to 100ms (actual closure time).

To connect the Stop/Start input from an external device, wire Terminals 5 and 6 from the contact closure. If using a solid state switching device, wire the connections ensuring that Terminal 5 is positive (+) and Terminal 6 is Common (-).

3.3 Adjustment

A. EW Pumps using the 'F' Control Module

The pump will operate best keeping the stroke length at 100%. If less than full output is required, set the frequency to the approximate percentage of maximum desired.

Example: Model EWB20F1-VC has maximum output of 1.8 GPH.

Desired output is 1.2 GPH. $1.2 \div 1.8 = 0.667$ or 67%

Using the UP and DOWN arrows, set the frequency of the pump to

$0.67 \times 360 = 241$ SPM.

For outputs less than 2% of maximum it will be necessary to also reduce the stroke length. (Minimum recommended stroke length is 20%.) It is good practice to change the frequency first, however, if low flows are required, a balanced turndown of speed and stroke length will yield the best results.

B. EK Pumps using the 'R' Control Module

The pump will operate best keeping the stroke length at 100%. If less than full output is required, set the frequency to the approximate percentage of maximum desired.

Example: Model EKC20R1-VC has maximum output of 4.3 GPH.

Desired output is 3.0 GPH. $3.0 \div 4.3 = 0.7$ or 70%

Using the UP and DOWN arrows, set the frequency of the pump to

$0.7 \times 360 = 252$ SPM.

For outputs less than 2% of maximum it will be necessary to also reduce the stroke length. (Minimum recommended stroke length is 20%.) It is good practice to change the frequency first, however, if low flows are required, a balanced turndown of speed and stroke length will yield the best results.

3.4 MultiFunction Valve Operation

The MultiFunction Valve is optional on select E-Class pumps and replaces the standard Manual Air Vent Valve when ordered. It integrates the air venting/bleeding functions with a back pressure and anti-siphon valve.

Air Vent / Bleed Function

1. Open the air vent by turning the air vent adjustment knob counter-clockwise one to one and a half turns.
2. Operate the pump until all of the air is purged and only liquid is discharged from the air vent drain.
3. Turn the air vent adjustment knob clockwise until it bottoms out and will not turn further.

Back Pressure / Anti-Siphon Valve

1. A spring-loaded diaphragm automatically adds 30PSI of back pressure to the discharge side of the pump when the air vent adjustment knob is closed.
2. If back pressure is not observed, the pressure release knob may be in the release position (the knob is resting in its 'up' location). If this is the case, turn the knob clockwise until it 'clicks' down (approximately $\frac{1}{4}$ turn).
3. The diaphragm prevents siphoning of chemical through the pump.

Pressure Release

1. Stop the pump operation.
2. Turn the pressure release knob clockwise until it 'clicks' into the release or 'up' location (approximately $\frac{1}{4}$ turn). If the knob is turned too far, it will 'click' again return to the back pressure or 'down' position. If this happens, keep turning the knob clockwise until it 'clicks' one time in the release ('up') position.
3. Turn the air vent adjustment knob counter-clockwise one or one and a half turns to release the pressure in the discharge tubing/piping through the air vent drain. The air vent drain should always be plumbed back to the supply tank or to safe disposal. Do not submerge the air vent drain tubing under chemical in the supply tank.

 **CAUTION:** Confirm that liquid is discharged from the air vent drain. If the liquid is not discharged, the pressure may not be released. If this is the case, repeat the Pressure Release procedure.

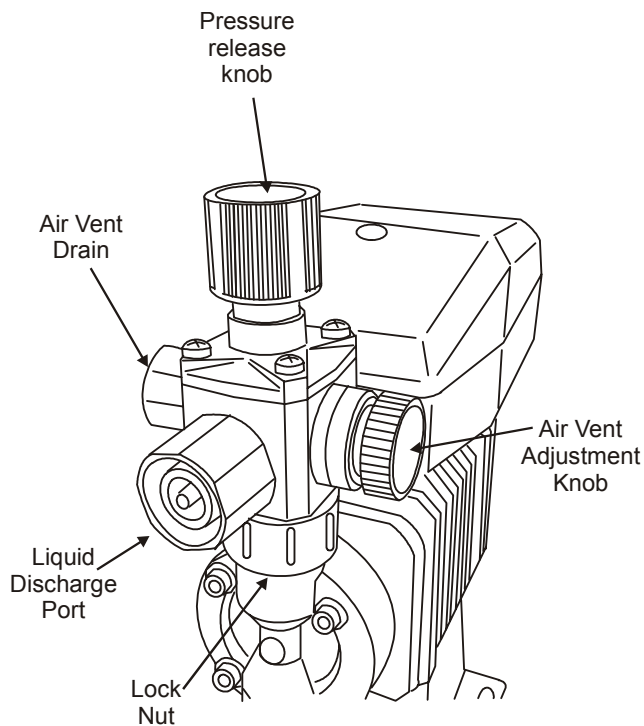

3.5 Auto Air Vent Valve Operation

The Auto Air Vent Valve is an option on select EW and EK pumps and replaces the standard Manual Air Vent Valve when ordered. It is used primarily in applications where gassing is a problem and pumps can lose prime.

Unlike the Manual Air Vent Valve, the Auto Air Vent Valve constantly bleeds a controlled amount of volume out of the “Air” vent. Therefore, the “Air” vent should *always* be plumbed back to the source tank. During priming, the access knob does not have to be loosened as with a manual air vent valve as pressure is relieved through the vent. The Top Valve Guide assembly uses a bottom seat to ensure that air is not introduced into the discharge media and utilizes a precisely machined top seat that allows air to be quickly purged but limits the amount of liquid returned to the tank. A sleeve valve is used to maintain backpressure within the pump head, which helps speed the purging of air.

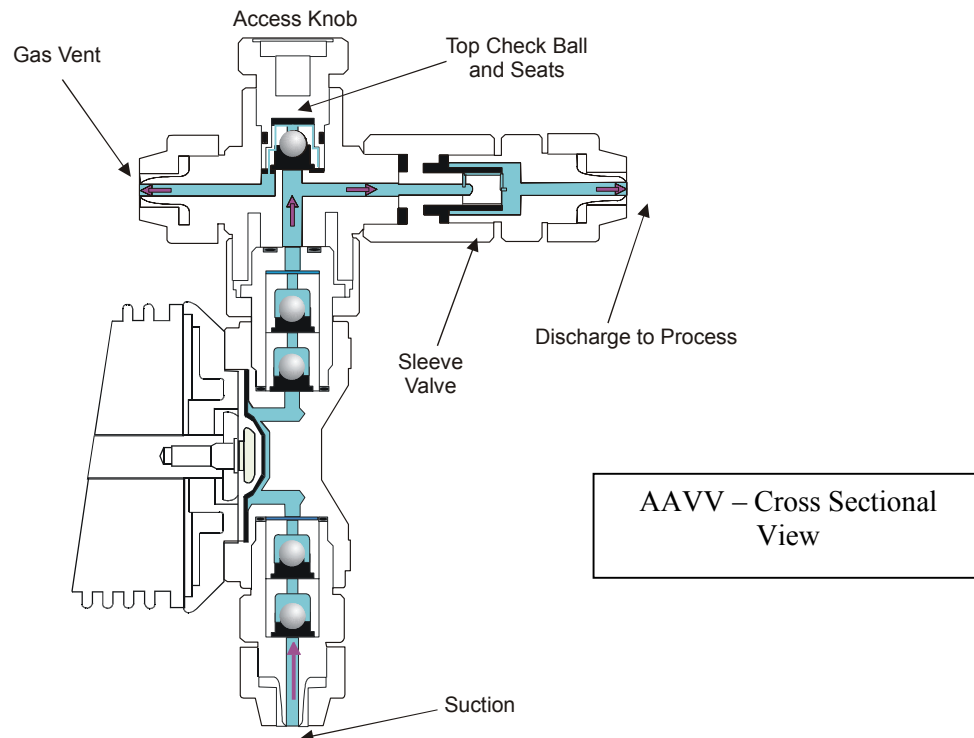

3.6 Priming

Install the pump as described in Section 2.0. With the pump turned on, set stroke length at 100% and frequency to 360 SPM. If the pump is equipped with an air vent valve, open the knob 1/2 turn. Liquid should move up through the suction tubing and into the pump head. When liquid starts running through the vent side tubing, close the air vent knob and continue with output adjustment described below. If the pump has no air vent valve, disconnect the discharge tubing from the injection valve. When liquid enters the discharge tubing at the pump head, stop the pump. Then reconnect the discharge tubing to the injection valve.

If the pump does not self prime, remove the check valve housing on discharge & suction sides to make sure valve cartridges and gaskets are in correct positions (see section 4.2 for correct orientation).

Note: Pumps with FC liquid ends may need assistance if dry priming due to the hard valve seat material.

3.7 Calibration

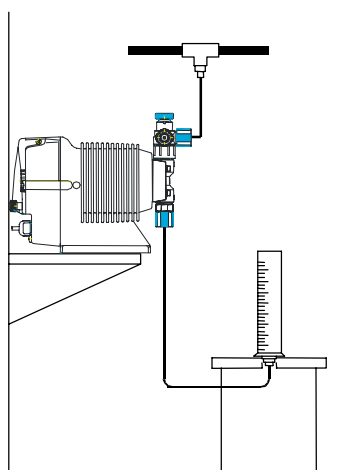

Figure 8 Calibration

If exact output calibration is required, first prime and adjust the pump as above. Then connect a calibration column to the suction side of the pump. Turn the pump on for one minute and read the amount of liquid pumped from the column. Adjust the frequency up or down as necessary and check the output again. When the desired output is reached, disconnect the calibration column and reconnect the suction tubing. (See Figure 8.) Calibration must be performed with actual application equivalent back pressure for accurate results. Published flow rates are based on maximum pressures. Lower pressures may result in slightly higher flow rates.

3.8 AC Power Interruption

If AC power is interrupted, the pump will power up as shown below:

State preceding power OFF	State following power ON
WAIT	WAIT
Run Manual	Run Manual
Run external	Run external

4.0 MAINTENANCE

CAUTION: Before working on the pump, disconnect the power cord, depressurize the discharge tubing and drain or flush any residual liquid from the pump head and valves. Always wear protective gear when working around chemicals.

4.1 Diaphragm Replacement

Disconnect AC power to the pump and disconnect the suction tubing, discharge tubing, and air vent tubing. Remove the four head bolts with a 4mm or 5mm hex wrench. Turn the stroke length knob fully counter-clockwise. Unscrew the diaphragm and remove its retainer (small disk behind the diaphragm). **CAUTION: There may be small brass spacers between the retainer and the armature shaft. These spacers need to be reused when replacing the diaphragm.** Install the new retainer and diaphragm on the shaft. Turn the diaphragm clockwise until it bottoms on the shaft. Replace the pump head and tighten the head bolts to a torque of 19 lb-in (2.16 N-m).

4.2 Valve Replacement

Remove the suction and discharge tubing making sure discharge side has been depressurized. Remove the suction fitting, two valve cartridges, o-ring and gasket(s). Install the new o-ring, gasket(s) and valve cartridges. Be sure both valve seats are in the same orientation. Refer to Figure below. Tighten the suction fitting. Similarly remove and replace the discharge valve cartridges, o-ring and gasket(s). For a more detailed drawing, refer to the Section 6.0.

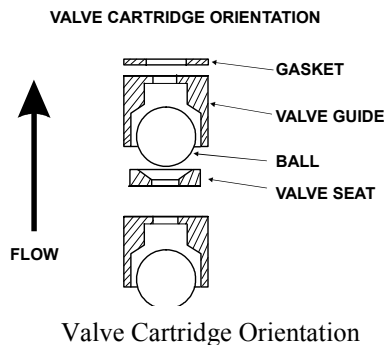

CAUTION: There are many small parts in the liquid end. These parts must be installed correctly for proper operation of the pump.

4.3 Tubing

Check ends of tubing for splits, cracks, or thin spots. Examine the full length of tubing for damage due to chafing, abrasion, stress cracks, excessive temperature or exposure to ultraviolet light (direct sunlight or mercury vapor lamps). If any signs of deterioration exist, replace the entire length of tubing. It is a good idea to replace discharge tubing on a regular preventive maintenance schedule every 12 months.

5.0 EXPLODED VIEW & PARTS GUIDE

PVC/GFRPP Liquid End Exploded View #1 For EW and EK pump model sizes 10, 15, and 20

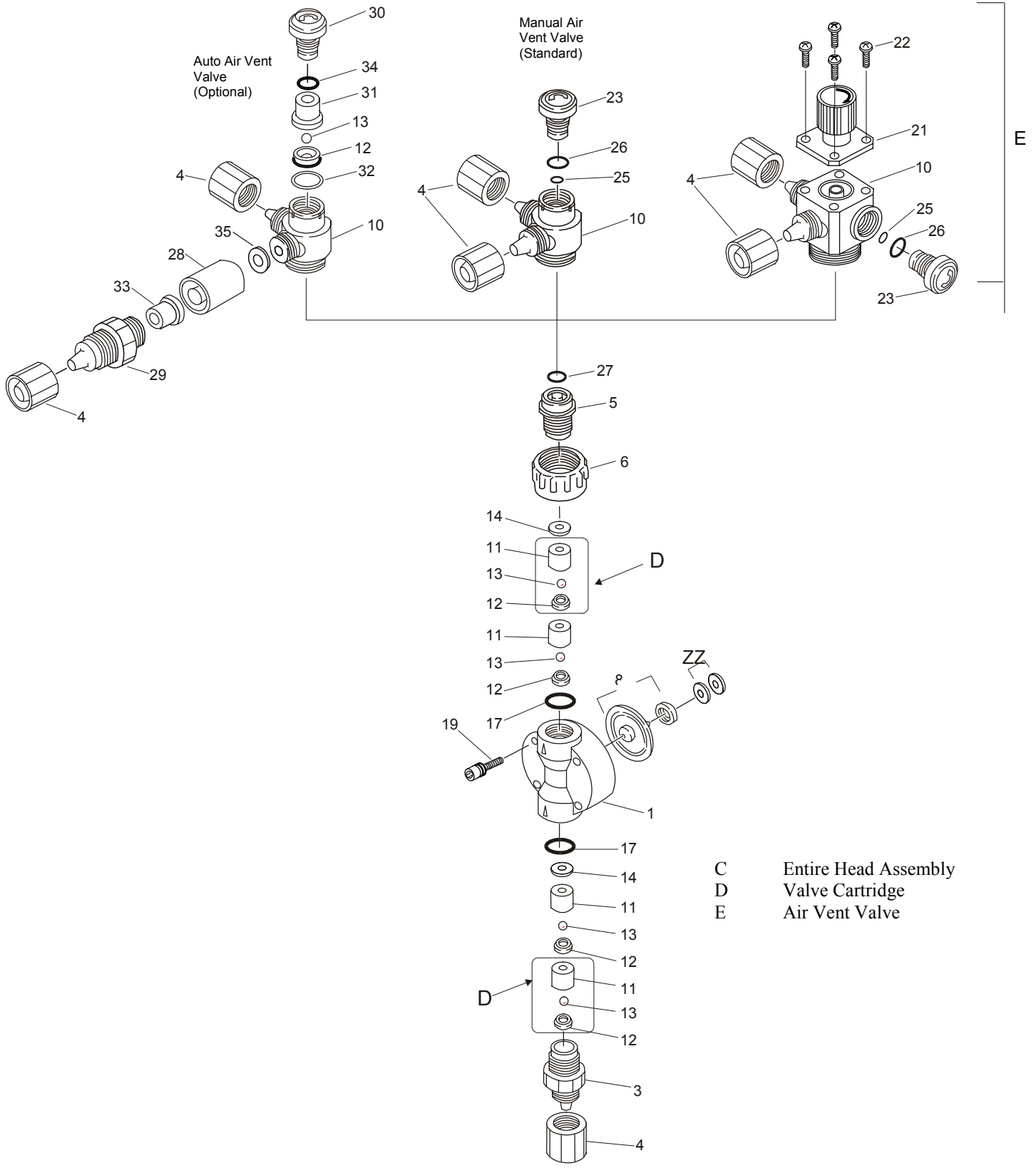

PVC/GFRPP Liquid End Exploded View #1

Components

Item	Part No	Description	Qty	Size	Liquid End Material
1	EH1339	Head, Pump, EW/EK10, PVC	1	10	VC, VE, VF
	EH1344	Head, Pump, EW/EK10, GFRPP	1	10	PC, PE
	EH0557	Head, Pump, EW/EK/EZ15, PVC	1	15	VC, VE, VF
	EH0582	Head, Pump, EW/EK/EZ15, GFRPP	1	15	PC, PE
	EH0564	Head, Pump, EW/EK/EZ20, PVC	1	20	VC, VE, VF
	EH0584	Head, Pump, EW/EK/EZ20, GFRPP	1	20	PC, PE
3	EH0400	Housing, Valve, 3/8 PVC	1	10, 15, 20	VC, VE, VF
	EH0418	Housing, Valve, 3/8 GFRPP	1	10, 15, 20	PC, PE
4	EH0401	Nut, Coupling, 3/8 PVC	3	10, 15, 20	VC, VE, VF
	EH0419	Nut, Coupling, 3/8 GFRPP	3	10, 15, 20	PC, PE
5	EH0294	Fitting, Air Vent, PVC	1	10, 15, 20	VC, VE, VF
	EH0315	Fitting, Air Vent, GFRPP	1	10, 15, 20	PC, PE
6	EH0295	Nut, Lock, Air Vent, PVC	1	10, 15, 20	VC, VE, VF
	EH0316	Nut, Lock, Air Vent, GFRPP	1	10, 15, 20	PC, PE
* 8	E90064	Diaphragm and Retainer, EW/EK/EZ10	1	10	all
	E90065	Diaphragm and Retainer, EW/EK/EZ15	1	15	all
	E90066	Diaphragm and Retainer, EW/EK/EZ20	1	20	all
10	EH0402	Body, Manual Air Vent, PVC	1	10, 15, 20	VC, VE, VF
	EH0420	Body, Manual Air Vent, GFRPP	1	10, 15, 20	PC, PE
	EH0861	Body, Auto Air Vent, PVC	1	10, 15, 20	VCA, VCC
	EH1406	Body, Multifunction Valve, PVC	1	10, 15, 20	VC, VEM, VFM
	EH1407	Body, Multifunction Valve, GFRPP	1	10, 15, 20	PCM, PEM
* 11	EH0060	Guide, Valve, .188 PVC	4	10	VC, VE, VF
	EH0318	Guide, Valve, .188 GFRPP	4	10	PC, PE
	EH0068	Guide, Valve, .250 PVC	4	15, 20	VC, VE, VF
	EH0325	Guide, Valve, .250 GFRPP	4	15, 20	PC, PE
* 12	EH0061	Seat, Valve, .188 FKM	4 (5)	10	VC, PC (VCC)
	EH0048	Seat, Valve, .188 EPDM	4	10	VE, PE, VF
	EH0069	Seat, Valve, .250 FKM	4	15, 20	VC, PC
	EH0071	Seat, Valve, .250 EPDM	4	15, 20	VE, PE, VF
* 13	EH0025	Ball, Valve, .188 CE	4 (5)	10	VC, VE, PC, PE, (VCC)
	EH0084	Ball, Valve, .250 CE	4	15, 20	VC, VE, PC, PE
	E00063	Ball, Valve 0.188 PTFE	4	10	VF
	E00064	Ball, Valve 0.250 PTFE	4	15, 20	VF
* 14	EH0026	Gasket, Valve, .188 & .250 PTFE	2	10, 15, 20	VC, VE, VF
	EH0580	Gasket, Valve, .188 & .250 PTFE	2	10, 15, 20	PC, PE
* 17	EH0027	O-Ring, S14 FKM	2	10, 15, 20	VC, PC
	EH0050	O-Ring, S14 EPDM	2	10, 15, 20	VE, PE, VF
19	EH1630	Bolt, M4 x 30 SS Hex Socket	4	10, 15, 20	all
21	E90374	Multifunction Valve Top Asm	1	10, 15, 20	all xxM ends
22	EH1410	Screw, M4 x 10, SS304, PP	4	10, 15, 20	all xxM ends
23	EH0299	Knob, Manual Air Vent Valve, PVC	1	10, 15, 20	VC, VE, VF
	EH0321	Knob, Manual Air Vent Valve, GFRPP	1	10, 15, 20	PC, PE
* 25	EH0300	O-Ring, P4 FKM	1	10, 15, 20	VC, PC
	EH0301	O-Ring, P4 EPDM	1	10, 15, 20	VE, PE, VF
* 26	EH0302	O-Ring, P10A FKM	1	10, 15, 20	VC, PC
	EH0303	O-Ring, P10A EPDM	1	10, 15, 20	VE, PE, VF
* 27	EH0304	O-Ring, P7 FKM	1	10, 15, 20	VC, PC
	EH0305	O-Ring, P7 EPDM	1	10, 15, 20	VE, PE, VF
28	EH0864	Fitting, Adapter, AAVV, PVC	1	10, 15, 20	VCC
29	EH0867	Fitting, AAVV, PVC	1	10, 15, 20	VCC
30	EH0774	Knob, AAVV, PVC	1	10, 15, 20	VCC
31	EH0862	Guide, Valve, AAVV, Titanium	1	10, 15, 20	VCC
32	EH0775	Spacer, AAVV, PVC	1	10, 15, 20	VCC
* 33	EH0865	Tube, Valve, AAVV, FKM	1	10, 15, 20	VCC
* 34	EH0776	O-Ring, S12, FKM	1	10, 15, 20	VCC
35	EH0866	Gasket, AAVV, FKM	1	10, 15, 20	VCC
ZZ	-----	Brass Spacers			Drive specific/Reuse when replacing diaphragm
* ZZ					Included in spare parts kit

PVC/GFRPP Liquid End Exploded View #2
 For EW and EK pump model sizes 30 and 35

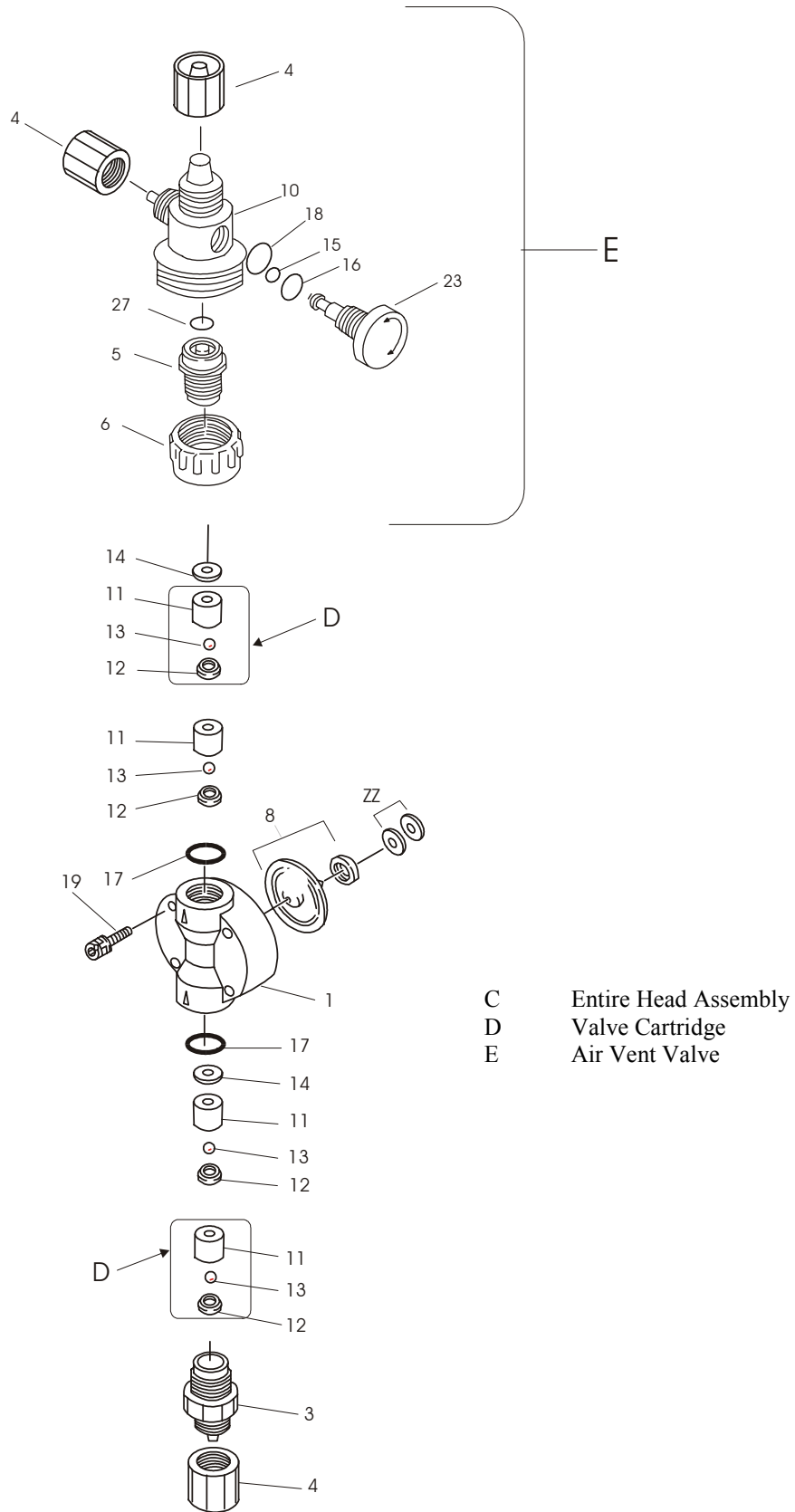

PVC/GFRPP Liquid End Exploded View #2

Components

Item	Part No	Description	Qty	Size	Liquid End Material
1	EH1345	Head, Pump, EW/EK30, GFRPP	1	30	PC, PE
	EH1340	Head, Pump, EW/EK30, PVC	1	30	VC, VE, VF
	EH1346	Head, Pump, EW/EK35, GFRPP	1	35	PC, PE
	EH1341	Head, Pump, EW/EK35, PVC	1	35	VC, VE, VF
3	EH0405	Housing, Valve, 1/2 PVC	1	30, 35	VC, VE, VF
	EH0421	Housing, Valve, 1/2 GFRPP	1	30, 35	PC, PE
4	EH0406	Nut Coupling, 1/2 PVC	3	30, 35	VC, VE, VF
	EH0422	Nut, Coupling, 1/2 GFRPP	3	30, 35	PC, PE
5	EH1078	Fitting, Air Vent, PVC	1	30, 35	VC, VE, VF
	EH1088	Fitting, Air Vent, GFRPP	1	30, 35	PC, PE
6	EH1077	Nut, Lock, Air Vent, PVC	1	30, 35	VC, VE, VF
	EH1087	Nut, Lock, Air Vent, GFRPP	1	30, 35	PC, PE
*	8	E90067 Diaphragm and retainer, EW/EK/EZ30	1	30	all
	E90490	Diaphragm & Retainer, EW/EK/EZ35	1	35	all
10	EH1101	Body, Manual Air Vent, PVC	1	30, 35	VC, VE, VF
	EH1099	Body, Manual Air Vent, GFRPP	1	30, 35	PC, PE
*	11	EH0118 Guide, Valve, 0.375 PVC	4	30, 35	VC, VE, VF
	EH0332	Guide, Valve, 0.375 GFRPP	4	30, 35	PC, PE
*	12	EH0119 Seat, Valve, 0.375 FKM	4	30, 35	VC, PC
	EH0125	Seat, Valve, 0.375 EPDM	4	30, 35	VE, PE, VF
*	13	EH0120 Ball, Valve, 0.375 CE	4	30, 35	VC, VE, PC, PE
	E00062	Ball, Valve, 0.375 PTFE	4	30, 35	VF
*	14	EH0121 Gasket, Valve, 0.375 PTFE	2	30, 35	VC, VE, PC, PE, VF
*	15	EH1080 O-Ring, P-3, FKM	1	30, 35	VC, PC
	EH1083	O-Ring, P-3, EPDM	1	30, 35	VE, PE, VF
*	16	EH0029 O-Ring, P-6, FKM	1	30, 35	VC, PC
	EH0052	O-Ring, P-6, EPDM	1	30, 35	VE, PE, VF
*	17	EH0122 O-Ring, P16 FKM	2	30, 35	VC, PC
	EH0127	O-Ring, P16 EPDM	2	30, 35	VE, PE, VF
*	18	EH0027 O-Ring, S-14 FKM	1	30, 35	VC, PC
	EH0050	O-Ring, S-14 EPDM	1	30, 35	VE, PE, VF
19	EH0403	Bolt, M4 x 33 SS Hex Socket	4	30	all
	EH1347	Bolt, M5 x 35 SS Hex Socket	4	35	all
23	EH1079	Knob, Manual Air Vent, PVC	1	30, 35	VC, VE, VF
	EH1089	Knob, Manual Air Vent, GFRPP	1	30, 35	PC, PE
*	27	EH1082 O-Ring, P-11 FKM	1	30, 35	VC, PC
	EH1084	O-Ring, P-11, EPDM	1	30, 35	VE, PE, VF
	ZZ	----- Brass Spacers			Drive specific/Reuse when replacing diaphragm

* Included in spare parts kit

PVDF Liquid End Exploded View #3

For all PVDF EW and EK Pump Models

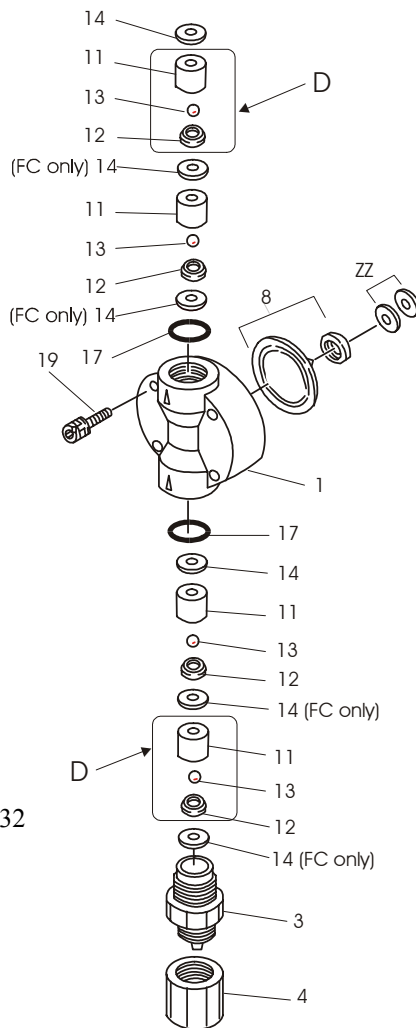
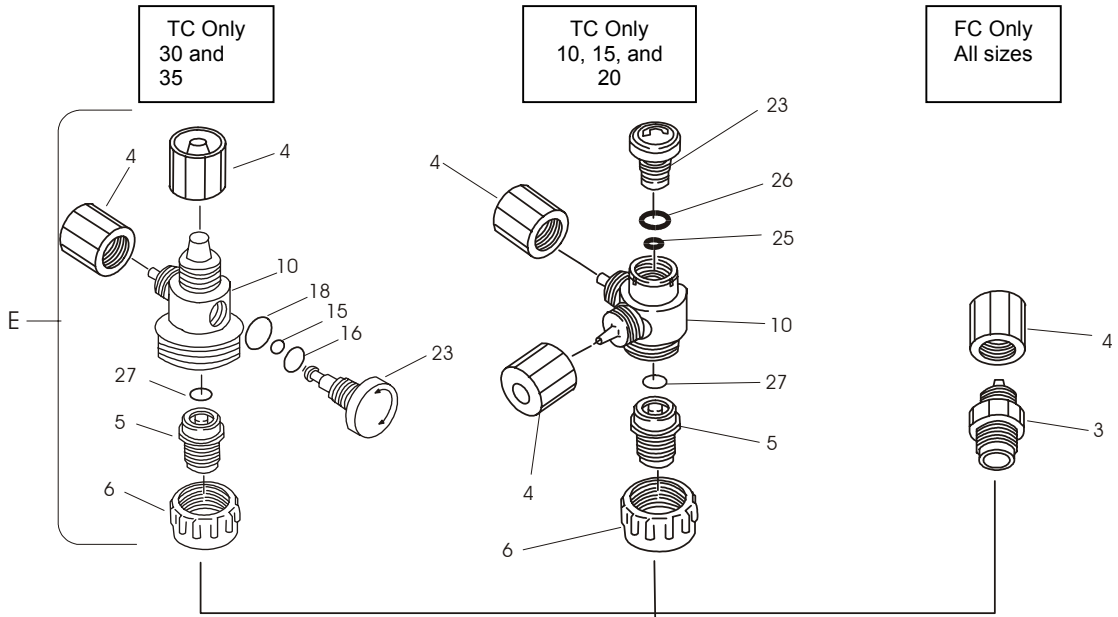

- C Entire Head Assembly
- D Valve Cartridge
- E Air Vent Valve

Part numbers for these assemblies are on Page 32

PVDF Liquid End Exploded View #3

Components

Item	Part No	Description	Qty	Size	Liquid End Material
1	EH0608	Head, Pump, EW/EK/EZ10, PVDF	1	10	FC, TC
	EH0609	Head, Pump, EW/EK/EZ15, PVDF	1	15	FC, TC
	EH0610	Head, Pump, EW/EK/EZ20, PVDF	1	20	FC, TC
	EH1538	Head, Pump, EW/EK30, PVDF	1	30	FC, TC
	EH1518	Head, Pump, EW/EK35, PVDF	1	35	FC, TC
3	EH0425	Housing, Valve, 3/8 PVDF	2 / 1	10, 15, 20	FC / TC
	EH0427	Housing, Valve, 1/2 PVDF	2 / 1	30, 35	FC / TC
4	EH0836	Nut, Coupling, 3/8 PVDF	2 / 3	10, 15, 20	FC / TC
	EH0837	Nut, Coupling, 1/2 PVDF	2 / 3	30, 35	FC / TC
5	EH1051	Fitting, Air Vent, PVDF	1	10, 15, 20	TC
	EH1093	Fitting, Air Vent, PVDF	1	30, 35	TC
6	EH1047	Nut, Lock, Air Vent, PVDF	1	10, 15, 20	TC
	EH1092	Nut, Lock, Air Vent, PVDF	1	30, 35	TC
*	8	E90064 Diaphragm and retainer, EW/EK/EZ10	1	10	all
		E90065 Diaphragm and retainer, EW/EK/EZ15	1	15	all
		E90066 Diaphragm and retainer, EW/EK/EZ20	1	20	all
		E90067 Diaphragm and retainer, EW/EK/EZ30	1	30	all
		E90490 Diaphragm and retainer, EW/EK/EZ35	1	35	all
10	EH1052	Body, Manual Air Vent, PVDF	1	10, 15, 20	TC
	EH1100	Body, Manual Air Vent, PVDF	1	30, 35	TC
*	11	EH0340 Guide, Valve, .188 PVDF	4	10	FC
		EH1046 Guide, Valve, .188 PVDF	4	10	TC
		EH1549 Guide, Valve, .250 PVDF	4	15, 20	FC, TC
		EH1550 Guide, Valve, .375 PVDF	4	30, 35	FC, TC
*	12	EH1627 Seat, Valve, .188 PCTFE	4	10	FC
		EH0592 Seat, Valve, .250 PCTFE	4	15, 20	FC
		EH0593 Seat, Valve, .375 PCTFE	4	30, 35	FC
		EH0061 Seat, Valve, .188 FKM	4	10	TC
		EH0069 Seat, Valve, .250 FKM	4	15, 20	TC
		EH0119 Seat, Valve, .375 FKM	4	30, 35	TC
		EH0025 Ball, Valve, .188 CE	4	10	FC, TC
*		EH0084 Ball, Valve, .250 CE	4	15, 20	FC, TC
		EH0120 Ball, Valve, .375 CE	4	30, 35	FC, TC
	14	EH0342 Gasket, Valve, .188 & .250 PTFE	6 / 2	10, 15, 20	FC / TC
	EH0354 Gasket, Valve, .375, PTFE	6 / 2	30, 35	FC / TC	
15	EH1080 O-Ring, P-3, FKM	1	30, 35	TC	
16	EH0029 O-Ring, P-6, FKM	1	30, 35	TC	
*	17	EH0027 O-Ring, S-14, FKM	2	10, 15, 20	TC
		EH0122 O-Ring, P-16, FKM	2	30, 35	TC
		EH0591 Gasket, V-Housing, .188/.250 PTFE	2	10, 15, 20	FC
		EH0355 Gasket, V-Housing, .375 PTFE	2	30, 35	FC
*	18	EH0027 O-Ring, S-14, FKM	1	30, 35	TC
	19	EH0403 Bolt, M4 x 33 SS Hex Socket	4	30	FC, TC
	EH1630 Bolt, M4 x 30 SS Hex Socket	4	10, 15, 20	FC, TC	
	EH1347 Bolt, M5 x 35 SS Hex Socket	4	35	FC, TC	
23	EH1049 Knob, Air Vent Valve	1	10, 15, 20	FC, TC	
	EH1094 Knob, Air Vent, 1/2, PVDF	1	30, 35	FC, TC	
* 25	EH0300 O-Ring, P-4, FKM	1	10, 15, 20	TC	
* 26	EH0302 O-Ring, P-10A, FKM	1	10, 15, 20	TC	
* 27	EH0304 O-Ring, P-7, FKM	1	10, 15, 20	TC	
	EH1082 O-Ring, P-11, FKM	1	30, 35	TC	
ZZ	-----	Brass spacers			Drive specific/Re-use when replacing diaphragm
*	Included in spare parts kit				

Accessories (Not Shown)

Part No.	Description	Size	Liquid End Material
E90001	Valve, Injection 3/8	10, 15, 20	VC
E90002	Valve, Injection 3/8	10, 15, 20	VE, VF
E90003	Valve, Injection, 3/8	10, 15, 20	PC
E90004	Valve, Injection, 3/8	10, 15, 20	PE
E90005	Valve, Injection 1/2	EHC30	VC
E90006	Valve, Injection 1/2	EHC30	VE, VF
E90007	Valve, Injection, 1/2	EZ30/35, EHB30, EHC35	VC
E90008	Valve, Injection, 1/2	EZ30/35, EHB30, EHC35	VE, VF
E90009	Valve, Injection, 1/2	EHC30	PC
E90010	Valve, Injection, 1/2	EHC30	PE
E90011	Valve, Injection, 1/2	EZ30/35, EHB30, EHC35	PC
E90012	Valve, Injection, 1/2	EZ30/35, EHB30, EHC35	PE
E90238	Valve, Injection, 3/8	10, 15, 20	TC
E90020	Valve, Inj/Back Press, 3/8	10, 15, 20	FC
E90022	Valve, Inj/Back Press, 1/2	30, 35	TC, FC
E90013	Valve, Foot, 3/8	10, 15, 20	VC
E90015	Valve, Foot, 3/8	10, 15, 20	PC
E90016	Valve, Foot, 1/2	30, 35	VC
E90018	Valve, Foot, 1/2	30, 35	PC
E90034	Valve, Foot, 3/8	10, 15, 20	PE
E90035	Valve, Foot, 3/8	10, 15, 20	VE
E90036	Valve, Foot, 1/2	30, 35	PE
E90037	Valve, Foot, 1/2	30, 35	VE
E90193	Valve, Foot, 1/2	30, 35	VF
E90234	Valve, Foot, 3/8	10, 15, 20	VF
E90239	Valve, Foot, 1/2	30, 35	TC
E90240	Valve, Foot, 3/8	10, 15, 20	TC
E90241	Valve, Foot, 3/8	10, 15, 20	FC
E90275	Valve, Foot, 1/2	30, 35	FC
E00001-00	Tubing, 1/2 OD LLDPE per foot	30, 35	all
E00001	Tubing, 1/2 OD LLDPE, 20 FT	30, 35	all
E00001-50	Tubing, 1/2 OD LLDPE, 50 FT	30, 35	all
E00001-100	Tubing, 1/2 OD LLDPE, 100 FT	30, 35	all
E00001-250	Tubing, 1/2 OD LLDPE, 250 FT	30, 35	all
E00001-500	Tubing, 1/2 OD LLDPE, 500 FT	30, 35	all
E00002-00	Tubing, 3/8 OD LLDPE per foot	10, 15, 20	all
E00002	Tubing, 3/8 OD LLDPE, 20 FT	10, 15, 20	all
E00002-50	Tubing, 3/8 OD LLDPE, 50 FT	10, 15, 20	all
E00002-100	Tubing, 3/8 OD LLDPE, 100 FT	10, 15, 20	all
E00002-250	Tubing, 3/8 OD LLDPE, 250 FT	10, 15, 20	all
E00002-500	Tubing, 3/8 OD LLDPE, 500 FT	10, 15, 20	all
E00071	Weight, Ceramic	10,15,20,30,35	all

6.0 TROUBLESHOOTING

CAUTION: Before working on the pump, disconnect the power cord, depressurize the discharge tubing and drain or flush any residual liquid from the pump head and valves, using proper chemical handling techniques.

<u>Problem</u>	<u>Possible Cause</u>	<u>Corrective Action</u>
<i>Pump does not start</i>	Faulty wiring	Correct wiring
	Improper voltage	Connect to proper voltage source
	Electronic control unit is damaged	Replace control unit
<i>Pump does not prime</i>	Pump stroke length is too short stroke length as needed to obtain	Operate pump with stroke length set at 100% until primed. Then set desired output.
	Air in suction tubing	Reroute suction tubing to eliminate air trap
	Valve gasket is not installed	Install valve gasket
	Valve set assembly direction is wrong.	Reassemble valve set
	Pump is air locked	Open air vent valve
	Suction or discharge valve is clogged with foreign matter	Disassemble, inspect, clean
	Ball stuck to valve seat	Disassemble, inspect, clean

<u>Problem</u>	<u>Possible Cause</u>	<u>Corrective Action</u>
<i>Output fluctuates</i>	Suction or discharge valve is clogged with foreign matter	Disassemble, inspect, clean
	Air is trapped in pump	Open air vent valve
	Overfeeding	Install injection valve or back pressure valve
	Diaphragm is damaged	Replace diaphragm
<i>Liquid leaks</i>	Fitting or coupling nut is loose	Re-install (see section 2.3/2.4)
	Pump head is loose	Tighten pump head bolts Torque: 19 lb-in (2.16 N-m)
	Diaphragm is damaged	Replace diaphragm
	O-ring or valve gasket missing	Install o-ring or valve gasket

7.0 SERVICE POLICY

The EW and EK Series electronic metering pumps have a 2-year limited warranty. Contact your Walchem distributor for service.

W A L C H E M

Five Boynton Road Hopping Brook Park Holliston, MA 01746 USA TEL 508-429-1110 FAX 508-429-7433

WEBSITE: www.walchem.com