

# Cooling Tower Controllers



## WECT/WEDT400 Series

The WECT/WEDT410 Cooling Tower Controller with electrodeless (toroidal) conductivity sensor represents the latest in technological and innovative advancements from Walchem. The electrodeless sensor is almost immune to contamination by oils, scale, biofilm, or other coatings, resulting in a low maintenance system that provides reliable, effective control.

All of the standard features you'd expect in a conventional cooling tower controller are included, plus simple-to-use information management tools that enable water treatment professionals to deliver more effective service to their customers.

The WECT/WEDT controllers have the ability to store conductivity, pH/ORP, and temperature values, water usage, relay and flow switch status, and user settings. A USB stick is all that's needed to extract the information. Download logs from the USB stick to a PC at your convenience, or copy your preferred treatment program from another controller to speed start-up. It couldn't be easier!



### Summary of Key Benefits

- **Ensures Optimal Performance and Maximum Efficiency**  
Precise control of conductivity and chemical feed reduces water consumption and inhibits corrosion, solids precipitation, scale build-up and growth of algae or dangerous bacteria.
- **Spend More Time Selling**  
Electrodeless conductivity sensor is almost immune to contamination and coatings, which means you'll spend less time cleaning and calibrating sensors and spend more time selling!
- **Efficient Customer Service**  
Quickly identify system upsets by knowing exactly what happened and when. An event log can be downloaded to tell you precisely when pumps turned on, valves opened, and when there was flow or no-flow.
- **More Informative Monthly Reports**  
Download stored data from the controller to a USB flash stick. Use the data to easily develop reports that validate and verify water treatment results, and include actual water usage, system conductivity, temperature, and accumulated chemical feed and bleed times.
- **Save Time**  
Copy the user settings from your controller to a USB flash stick and upload to a new controller. Programming your new controller this way can be accomplished in seconds. It's that simple!



**W A L C H E M**

IWAKI America Inc.

# Features

## Feed and Bleed Cooling Tower Controller

- › **Four chemical feed options**
  - Feed & bleed, with or without feed lockout timer
  - Feed after bleed has finished, as a percentage of time
  - Feed as a percentage of time elapsed
  - Feed as a percentage of make-up water
- › **Self-Diagnostics**
  - Software, electronics, and sensor are constantly monitored without having to take controller offline.
- › **Conductivity Sensor**
  - Electrodeless, temperature compensated, CPVC
  - In-line or submersion
- › **4-20mA Output**
  - Optional isolated 4-20mA output proportional to the conductivity reading.
- › **Alarm Output Relay**
  - Triggered by low conductivity, high conductivity, no-flow conditions, bleed timeout, sensor error, and temperature error
- › **Flow Switch Manifolds**
  - Optional integrated flow switch manifold may be panel mounted for quick, professional installation with only two process connections.
- › **Flow Meter Input**
  - Accommodates a wide range of contacting and Hall Effect water meters
- › **USB Flashstick Support**
  - Standard for software upgrades and data logs, event/relay and reset logs, and user configuration file import/export

## Feed and Bleed Cooling Tower Controller with Dual Biocide Timers

The 410 Series offers all of the 400 features as well as:

- › **Programmable Dual Biocide Timers**
  - Choice of 1, 7, 14, or 28-day cycles
  - Able to: add a single biocide at any time or dual alternating biocides, or dual independent biocides
- › **pH or ORP Control (WEDT410 only)**
  - Choice of pH or ORP sensor for control of acid or chlorine/bromine addition
- › **Alarm Output Relay**
  - Triggered by low conductivity, high conductivity, no-flow conditions, bleed timeout, sensor error, and temperature error

## USB Features

Integrated datalogging collects analytical measurements at 10 minute intervals and captures all relay activations.

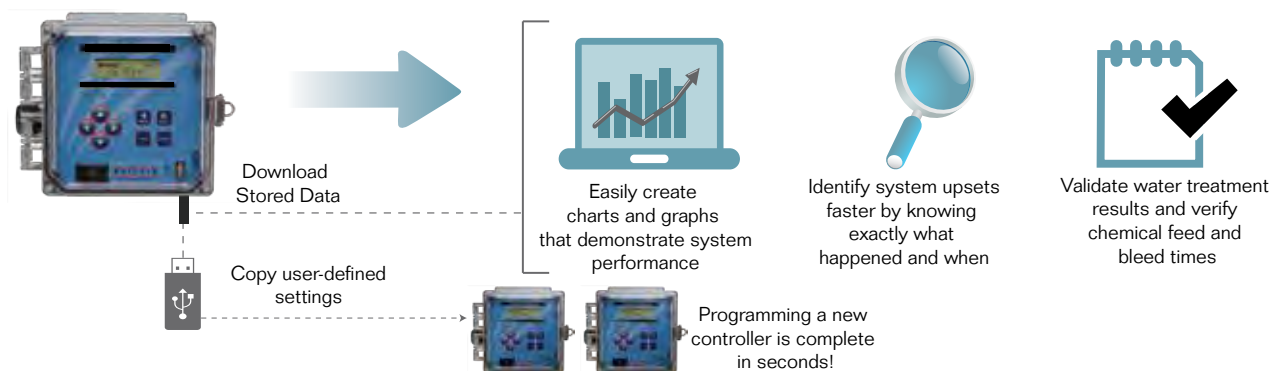

# Specifications

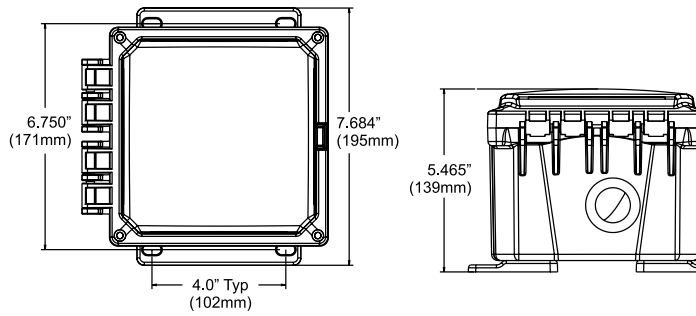

## Mechanical

<b>Enclosure</b>	Polycarbonate
<b>NEMA Rating</b>	NEMA 4X (IP65)
<b>Display</b>	2 x 16 character backlight liquid crystal
<b>Ambient Temperature</b>	32 to 122°F (0 to 50°C)
<b>Shipping weight</b>	24 lbs (10.9 kg) (approximately)

Flow switch manifold connections 3/4" NPTF

### Electrode Pressure Ratings:

Electrodeless conductivity	150 psi (10 bars)
pH/ORP	100 psi (6.9 bars)
Flow switch manifold	150 psi (10 bars)

## Measurement Performance

	Range	Resolution	Accuracy
Conductivity	100-10,000 µS/cm	1 µS	± 1% of reading
Temperature	32 to 158°F (0 to 70°C)	0.1°F (0.1°C)	± 1% of reading
pH (WEDT410 only)	-2 to +16 pH units	0.01 pH units	± 0.01 pH units (calibrated)
ORP (WEDT410 only)	±1500 mV	1 mV	± 1 mV (calibrated)

## Inputs

### Power

100-240 VAC, 50/60 Hz, 8A  
Fuse: 1.0 ampere, 5 x 20 mm

### Signals

Cond Sensor: 1.0 cell factor, 10K thermistor  
pH/ORP (WEDT410 only): Requires a preamplified signal. Walchem WEL series recommended. ±5V power available for external preamp  
Note: Temperature compensation for pH input is accomplished using the conductivity sensor temp element. ORP measurement does not use temp comp.

Flow Meter: (optional)	Isolated, dry contact closure required (i.e. relay, reed switch)
Flow Switch: (optional)	Isolated, dry contact closure required (i.e. reed switch)

## Outputs

### Mechanical Relays

WECT400: Two powered relays (Bleed, Feed)  
WECT410: Five powered relays (Bleed, Feed, Bio 1, Bio2, Alarm)  
WEDT410: Six powered relays (Bleed, Feed, Bio 1, Bio 2, pH/ORP, Alarm)  
6 A (resistive), 1/8 HP  
All relays are fused together as one group, total current for this group must not exceed 6A

### 4 - 20 mA (optional) (2 available for WEDT410)

Internally powered  
Fully isolated  
600 Ohm max resistive load  
Resolution .001% of span  
Accuracy ± 1% of reading

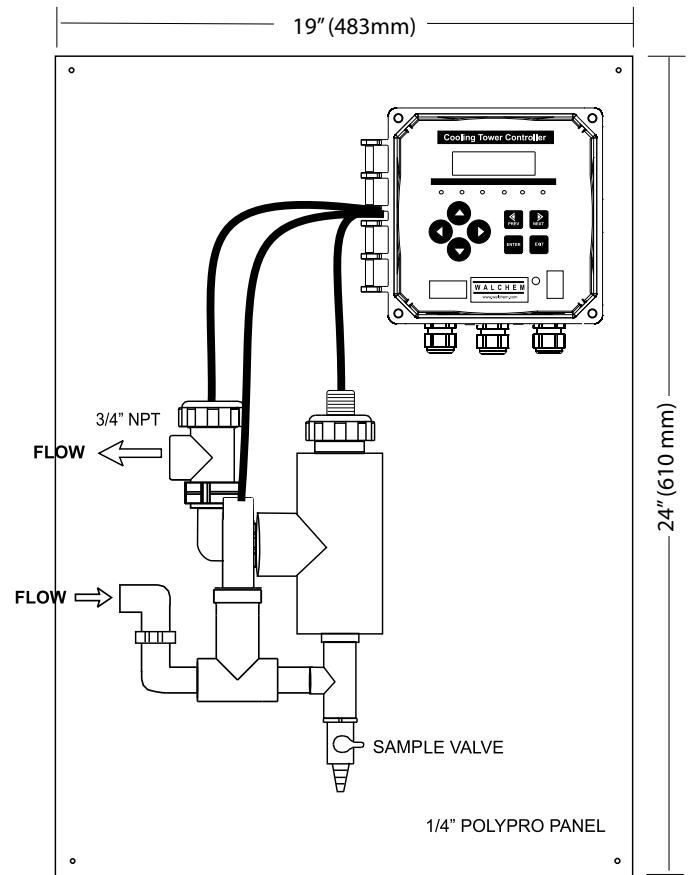

# Ordering Information

WECT400  
WECT410 —      
WEDT410 voltage output sensor USB

## VOLTAGE

1 = 120 VAC, prewired  
5 = 100-240 VAC, hardwired, cable glands

## OUTPUT

N = No analog output  
4 = Single isolated 4-20 mA output  
2 = WEDT410: Two isolated 4-20 mA outputs

## WECT SENSOR OPTIONS

N = No electrode  
1 = Electrodeless conductivity sensor & tee, 20 ft. cable (for inline mounting)  
2 = Electrodeless conductivity sensor & flow switch manifold on PP panel, 5 ft. cable  
2L= Electrodeless conductivity sensor & flow switch manifold (loose, no panel), 20 ft. cable  
3 = Submersion conductivity sensor (no tee or adapter), 20 ft. cable

## WEDT SENSOR OPTIONS

N = No electrodes  
1 = Electrodeless conductivity & pH sensors and tees, 20 ft. cable (for inline mounting)  
2R= Electrodeless conductivity & rod style ORP sensors and tees, 20 ft. cable (for inline mounting)  
3 = Electrodeless conductivity & pH sensors and flow switch manifold on PP panel  
3R= Electrodeless conductivity & rod style ORP sensors and flow switch manifold on PP panel

## USB FEATURES

U = Integrated datalogging, event/reset logging, and configuration file import/export

## AGENCY CERTIFICATIONS

Safety	UL 61010-1:2012 3rd Ed. CSA C22.2 No. 61010-1:2012 3rd Ed. IEC 61010-1:2010 3rd Ed. EN 61010-1:2010 3rd Ed.
EMC	IEC 61326-1:2005 EN 61326-1:2006

Note: For EN61000-4-6 & EN61000-4-3 the controller met performance criteria B.

\*Class A equipment: Equipment suitable for use in establishments other than domestic, and those directly connected to a low voltage (100-240 VAC) power supply network which supplies buildings used for domestic purposes.



### Webmaster®ONE

WebMasterONE is the most advanced online cooling tower and boiler controller in the water treatment industry. The flexible multi-I/O platform allows you to control multiple cooling towers, boilers, closed loops, and condensate lines with just one controller. An extensive assortment of integrated communications and data handling features are included that enable water treatment professional to provide more effective water management services to their customers.



### Metering Pumps

The E-Class is the most innovative and comprehensive metering pump product line in the world. Over 50 years of pump experience and a commitment to superior mechanical design has led to development of many industry firsts, including 360 stroke-per-minute technology, IP67 waterproof construction, and the world's highest capacity solenoid metering pumps.



### WIND WebMaster® Industrial Water Controllers

Walchem's WebMaster Industrial (WIND) Controller sets a new standard for Industrial Water Treatment Controllers. WIND has a flexible multi-I/O platform, a wide range of analytical sensor measurement capabilities, and an extensive assortment of integrated communications and data handling features.



### WebAlert® Remote Monitor

Walchem's WebAlert is the first stand alone remote monitoring device that can web enable your installed equipment without having to replace or upgrade it.

## ABOUT US

Walchem integrates its advanced sensing, instrumentation, fluid pumping and communications technologies to deliver reliable and innovative solutions to the global water treatment market. Our in-house engineering is driven by quality, technology and innovation. For more information on the entire Walchem product line, visit: [www.walchem.com](http://www.walchem.com)



**WALCHEM**  
IWAKI America Inc.

Walchem, Iwaki America Inc.  
Five Boynton Road Hopping Brook Park  
Holliston, MA 01746 USA  
Phone: 508-429-1110 [www.walchem.com](http://www.walchem.com)