

WALCHEM

IWAKI America Inc.

WCM400 Controllers

# WCM400 Series Condensate Conductivity Monitor Instruction Manual

Five Boynton Road Hopping Brook Park Holliston, MA 01746 USA

TEL: 508-429-1110 FAX: 508-429-7433 WEB: [www.walchem.com](http://www.walchem.com)

## Notice

© 2014 WALCHEM, Iwaki America Inc. (hereinafter "Walchem")  
5 Boynton Road, Holliston, MA 01746 USA  
(508) 429-1110  
All Rights Reserved  
Printed in USA

## Proprietary Material

*The information and descriptions contained herein are the property of WALCHEM. Such information and descriptions may not be copied or reproduced by any means, or disseminated or distributed without the express prior written permission of WALCHEM, 5 Boynton Road, Holliston, MA 01746.*

*This document is for information purposes only and is subject to change without notice.*

## Statement of Limited Warranty

*WALCHEM warrants equipment of its manufacture, and bearing its identification to be free from defects in workmanship and material for a period of 24 months for electronics and 12 months for mechanical parts and electrodes from date of delivery from the factory or authorized distributor under normal use and service and otherwise when such equipment is used in accordance with instructions furnished by WALCHEM and for the purposes disclosed in writing at the time of purchase, if any. WALCHEM's liability under this warranty shall be limited to replacement or repair, F.O.B. Holliston, MA U.S.A. of any defective equipment or part which, having been returned to WALCHEM, transportation charges prepaid, has been inspected and determined by WALCHEM to be defective. Replaceable elastomeric parts and glass components are expendable and are not covered by any warranty.*

*THIS WARRANTY IS IN LIEU OF ANY OTHER WARRANTY, EITHER EXPRESS OR IMPLIED, AS TO DESCRIPTION, QUALITY, MERCHANTABILITY, FITNESS FOR ANY PARTICULAR PURPOSE OR USE, OR ANY OTHER MATTER.*

**180332.J**  
**July 2014**

# TABLE OF CONTENTS

<b>1.0</b>	<b>INTRODUCTION.....</b>	<b>2</b>
<b>2.0</b>	<b>SPECIFICATIONS .....</b>	<b>2</b>
2.1	Measurement Performance .....	2
2.2	Electrical: Input/Output.....	2
2.3	Mechanical.....	3
2.4	WCM Variables and their Limits.....	3
<b>3.0</b>	<b>UNPACKING &amp; INSTALLATION .....</b>	<b>4</b>
3.1	Unpacking the unit .....	4
3.2	Mounting the electronic enclosure .....	4
3.3	Installation.....	4
3.4	Icon Definitions .....	4
3.5	Electrical installation .....	6
<b>4.0</b>	<b>FUNCTION OVERVIEW .....</b>	<b>9</b>
4.1	Front Panel .....	9
4.2	Display .....	9
4.3	Keypad.....	10
4.4	Access Code.....	10
4.5	Startup .....	10
4.6	Shut Down .....	10
<b>5.0</b>	<b>OPERATION.....</b>	<b>11</b>
5.1	Main Menu .....	11
5.2	Conductivity Menu .....	12
5.3	Temperature Menu .....	14
5.4	Divert Menu.....	15
5.5	Time Menu.....	16
5.6	4-20mA Menu .....	17
5.7	Access Code Menu.....	18
5.8	Datalog Menu.....	19
5.9	Config Menu.....	21
5.10	Upgrade Menu.....	22
<b>6.0</b>	<b>MAINTENANCE.....</b>	<b>23</b>
6.1	Electrode Cleaning.....	23
6.2	Replacing the Fuses .....	23
<b>7.0</b>	<b>TROUBLESHOOTING.....</b>	<b>24</b>
7.1	Error Messages.....	24
7.2	Conductivity Readout Does Not Change .....	25
7.3	Procedure for Evaluation of Conductivity Electrode.....	25
<b>8.0</b>	<b>SERVICE POLICY .....</b>	<b>26</b>

## 1.0 INTRODUCTION

---

The Walchem WCM400 Series monitors offer conductivity control of boiler condensate. If the conductivity rises above the set point, the monitor will activate a diverter valve to prevent the contaminated condensate from returning to the boiler and/or set off an alarm.

The WCM series condensate monitors are supplied with a temperature compensated electrode with a cell constant of 1.0. The monitors are microprocessor driven industrial type with on/off control outputs. An optional isolated 4-20 mA output that is proportional to the conductivity reading is available for all models.

Any set point may be viewed without interrupting control. Each set point change will take effect as soon as it is entered. An access code is available to protect set point parameters, while still allowing settings to be viewed.

Our unique USB feature provides the ability to upgrade the software in the controller to the latest version.

An advanced USB capability option is available. The Config file feature allows you to save all the set points from a controller onto a USB flash disk, and then import them into another controller, making the programming of multiple controllers fast and easy. The data logging feature allows you to save the last 2 month's readings and events to a USB flash disk.

## 2.0 SPECIFICATIONS

---

### 2.1 Measurement Performance

Conductivity Range	0 - 10,000 $\mu\text{S/cm}$ (microSiemens/centimeter)
Conductivity Resolution	1 $\mu\text{S/cm}$
Conductivity Accuracy	10 - 10,000 $\mu\text{S/cm}$ $\pm 1\%$ of reading 0 - 10 $\mu\text{S/cm}$ $\pm 20\%$ of reading
Temperature Range	32 - 392°F (0 - 200°C)
Temperature Resolution	0.1°C
Temperature Accuracy	$\pm 1\%$ of reading

### 2.2 Electrical: Input/Output

<b>Input Power</b>	100-240 VAC, 50/60 Hz, 8A Fuse: 1.0 ampere, 5 x 20 mm
<b>Outputs</b>	
Mechanical Relays	Pre-powered on circuit board switching line voltage 6 A (resistive), 1/8 HP All relays are fused together as one group, total current for this group must not exceed 6A.
4 - 20 mA (optional)	Internally powered Fully isolated 600 Ohm max resistive load Resolution .001% of span Accuracy $\pm 1\%$ of reading

### Agency Approvals

Safety	UL 61010-1:2012 3rd Ed. CSA C22.2 No. 61010-1:2012 3rd Ed. IEC 61010-1:2010 3rd Ed. EN 61010-1:2010 3rd Ed.
EMC	IEC 61326-1:2005 EN 61326-1:2006

Note: For EN61000-4-6, EN61000-4-3 the controller met performance criteria B.

\*Class A equipment: Equipment suitable for use in establishments other than domestic, and those directly connected to a low voltage (100-240 VAC) power supply network which supplies buildings used for domestic purposes.

## 2.3 Mechanical

Enclosure Material	Polycarbonate
NEMA Rating	NEMA 4X
Dimensions	8.5" x 6.5" x 5.5"
Display	2 x 16 character backlit liquid crystal
Operating Ambient Temp	32 – 122°F (0 – 50°C)
Storage Temperature	-20 – 180°F (-29 – 80°C)
Electrode mounting	¾" NPTF
Electrode rating	250 psi at 392°F (17.2 bars at 200°C)
Electrode material	316 SS and PEEK

## 2.4 WCM Variables and their Limits

		Low Limit	High Limit
<b>Conductivity menu</b>			
	PPM Conversion Factor	0.200 ppm/μS/cm	1.000 ppm/μS/cm
	% Calibration Range	-50	+50
<b>Temperature Menu</b>		No variables	
<b>Divert Menu</b> (set in hrs/minutes)			
	Set Point	0 μS/cm	10,000 μS/cm
	Dead Band	5 μS/cm	500 μS/cm
	Time Limit	1 minute	8 hrs:20 min (enabled) Unlimited (disabled)
<b>4-20 mA Menu</b>	4 & 20 mA Settings	0 μS/cm	10,000 μS/cm
<b>Access Code Menu</b>	New Value	0	9999
<b>Datalog Menu (Optional)</b>		No variables	
<b>Config Menu (Optional)</b>		No variables	
<b>Upgrade Menu</b>		No variables	

Note: The Alarm relay is non-programmable. Refer to the Main Menu diagram on page 16 for the list of error conditions that trigger the alarm relay.

## 3.0 UNPACKING & INSTALLATION

---

### 3.1 Unpacking the unit

Inspect the contents of the carton. Please notify the carrier immediately if there are any signs of damage to the monitor or its parts. Contact your distributor if any of the parts are missing. The carton should contain: a WCM400 series monitor and instruction manual. Any options or accessories will be incorporated as ordered.

### 3.2 Mounting the electronic enclosure

The WCM series monitor is supplied with mounting holes on the enclosure. It should be wall mounted with the display at eye level, on a vibration-free surface, utilizing all four mounting holes for maximum stability. Use M6 (1/4" diameter) fasteners that are appropriate for the substrate material of the wall. The enclosure is NEMA 4X rated. The maximum operating ambient temperature is 32 to 122°F (0 to 50°C); this should be considered if installation is in a high temperature location. The enclosure requires the following clearances:





Top:	2" (50 mm)
Left:	8" (203 mm)
Right:	4" (102 mm)
Bottom:	7" (178 mm)

### 3.3 Installation

The conductivity electrode should be placed as close to the monitor as possible, to a maximum distance of 250 ft. Under 25 ft is recommended. Over 25 ft, the cable may need to be shielded from background electrical noise. (The standard cable length is 10 feet. Should you require longer cable, consult factory.)

Locate the electrode tee where an active sample of condensate water is available and where the electrode can easily be removed for cleaning. It must be situated so that the tee is always full and the electrode is never subjected to a drop in water level resulting in dryness. Refer to Figure 1 for typical installation.

### 3.4 Icon Definitions

Symbol	Publication	Description
	IEC 417, No.5019	Protective Conductor Terminal
	IEC 417, No. 5007	On (Supply)
	IEC 417, No. 5008	Off (Supply)
	ISO 3864, No. B.3.6	Caution, risk of electric shock
	ISO 3864, No. B.3.1	Caution

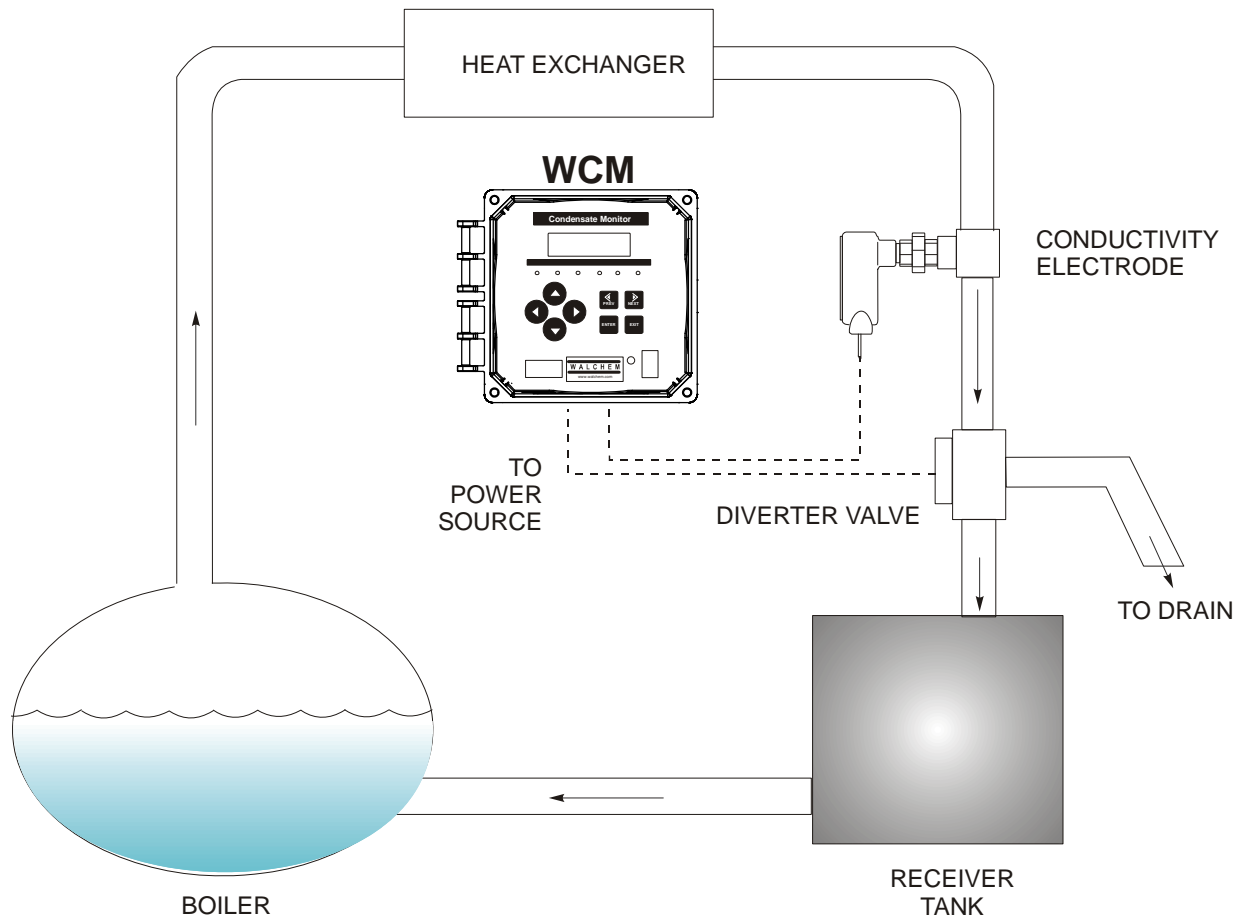

**Figure 1 Typical Installation**

### 3.5 Electrical installation

The various standard wiring options are shown in figure 2. Your WCM series monitor will arrive from the factory prewired or ready for hardwiring. Depending on your configuration of options, you may be required to hardwire some or all of the input/output devices. Refer to figures 3 and 4 for circuit board layout and wiring.



## CAUTION



1. There are live circuits inside the monitor even when the power switch on the front panel is in the OFF position! The front panel must never be opened before power to the monitor is REMOVED!  
If your monitor is prewired, it is supplied with a 8 foot, 18 AWG power cord with USA style plug. A tool (#1 Phillips driver) is required to open the front panel.
2. When mounting the monitor, make sure there is clear access to the disconnecting device!
3. The electrical installation of the monitor must be done by trained personnel only and conform to all applicable National, State and Local codes!
4. Proper grounding of this product is required. Any attempt to bypass the grounding will compromise the safety of persons and property.
5. Operating this product in a manner not specified by Walchem may impair the protection provided by the equipment.

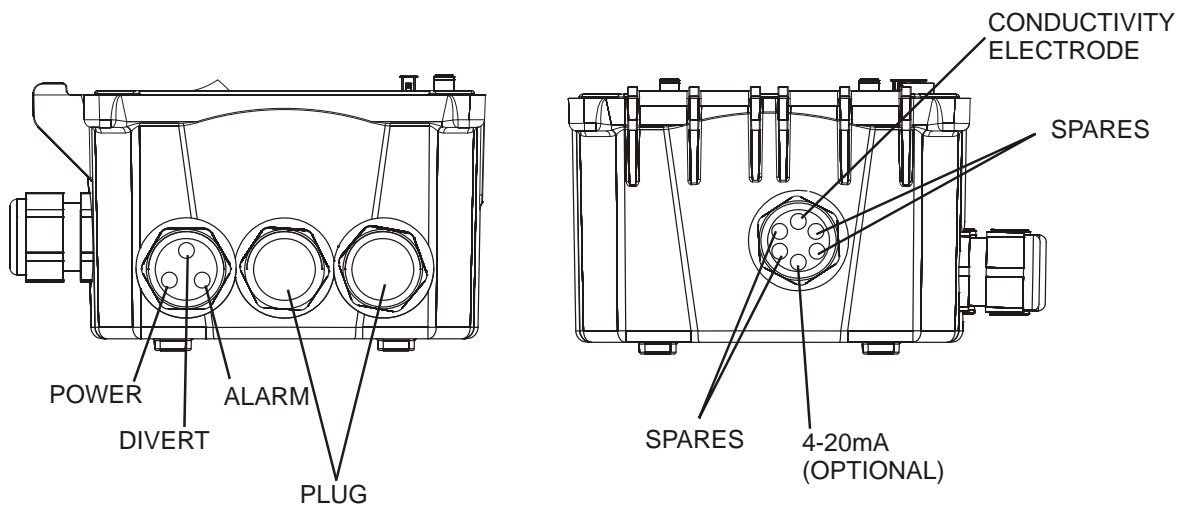

**Figure 2 Conduit/Wiring Configuration**



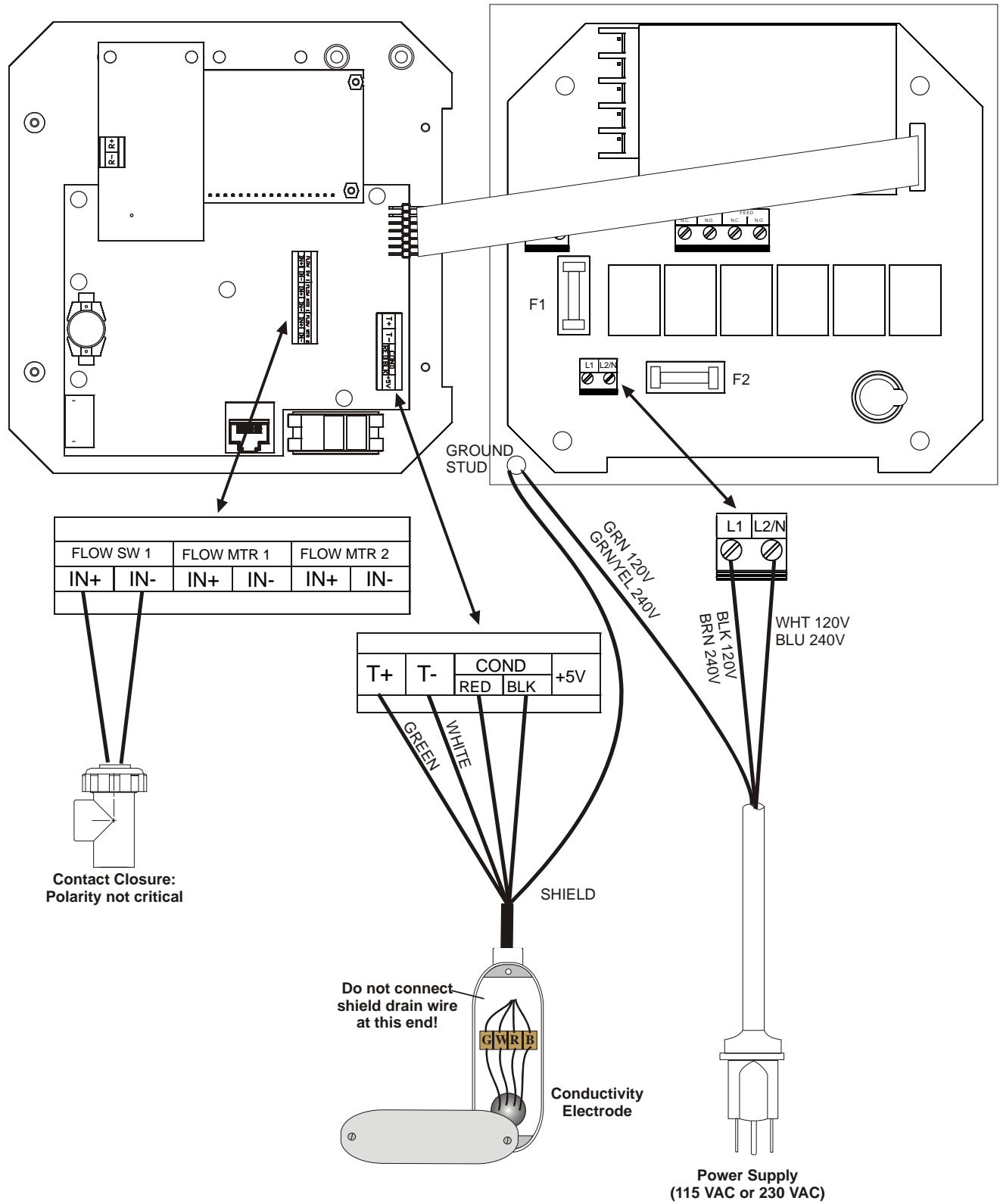

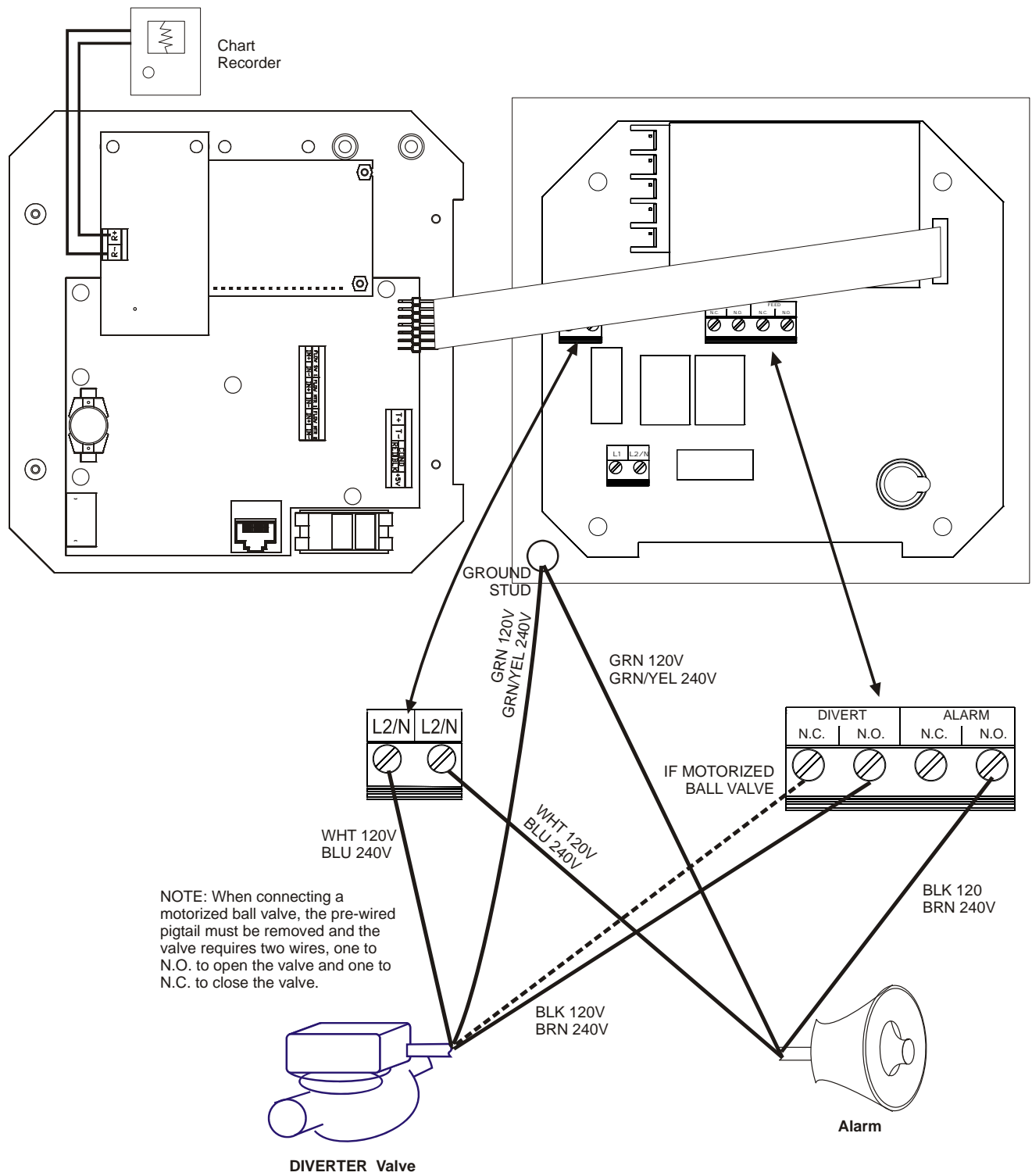

Figure 4 Outputs

## 4.0 FUNCTION OVERVIEW

### 4.1 Front Panel

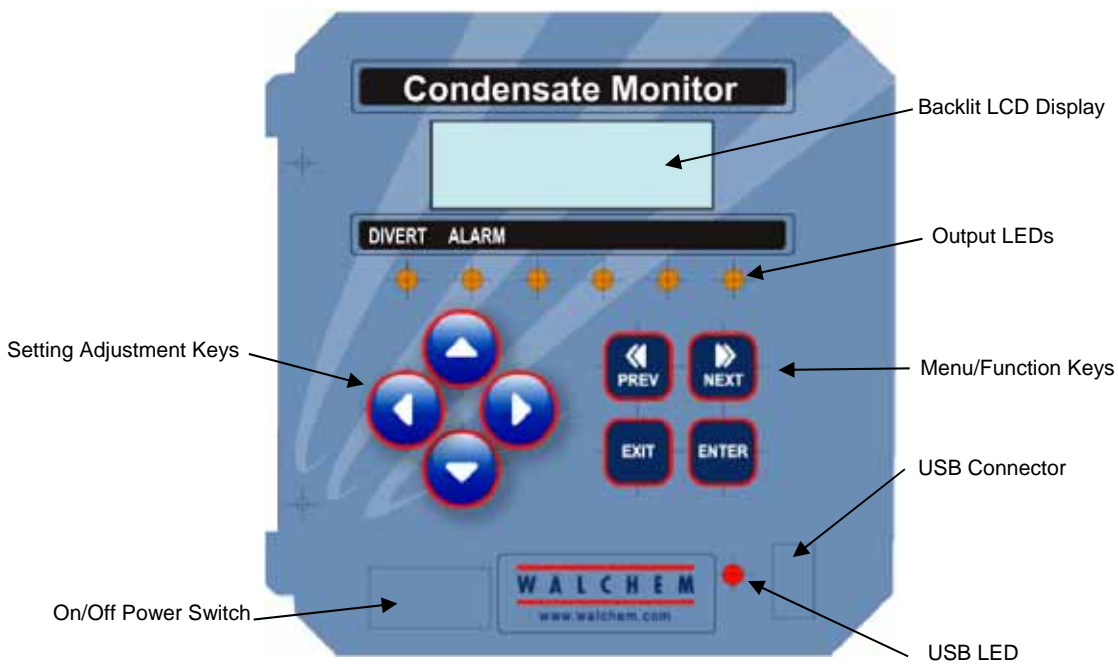

Figure 5 Front Panel

### 4.2 Display

A summary screen is displayed while the WCM monitor is on. This display shows a bar graph of the conductivity relative to the set point, the actual conductivity value, and current operating conditions. The center of the bar graph is at the (S), which represents the set point. For each 1% rise above the set point a vertical bar appears to the right of the (S). For each 1% drop below the set point a vertical bar appears to the left of the (S). There are small breaks in the bars at each 5%. The bar graph is limited to displaying 20% above or below the set point. The operating conditions that are displayed on the bottom line of this display are Divert, Cond Error, Temp Error, Divert Timeout and Normal. Normal just means there is nothing unusual to report.

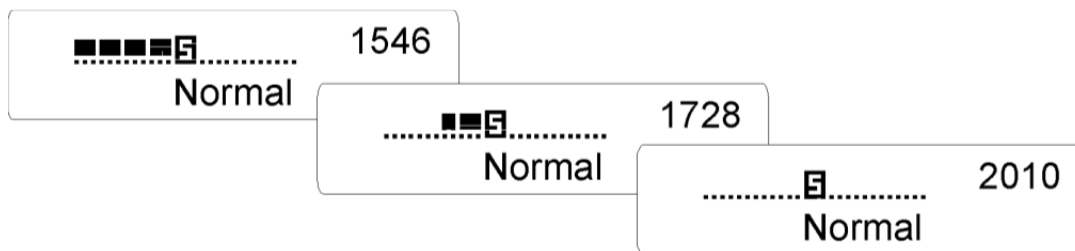

Figure 6 Summary Screen

### 4.3 Keypad

The keypad consists of 4 directional arrow keys and 4 function keys. The arrows are used to move the adjustment cursor and change settings, while the function keys are used to enter values, and navigate the various menu screens. The function keys are **ENTER**, **EXIT**, **NEXT**, and **PREV** (previous). **NEXT** and **PREV** scroll through the various menu choices. **ENTER** is used to enter a submenu and to enter a value. **EXIT** is used to back up one menu level. If you are at the main menu level, **EXIT** will return you to the Summary Display.



To change a value in a submenu, the left/right arrow keys move the cursor left and right to each digit or option that can be changed. The up/down arrows will change numeric values up or down, or scroll through option choices. Press **ENTER** only when you have finished making *all* of the changes for that menu screen.

### 4.4 Access Code

The WCM series monitor is shipped with the access code disabled. If you wish to enable it, see Section 5.6 for operation. With the access code enabled, any user can view parameter settings, but not change them. Note that this provides protection only against casual tampering. Use a lock on the cover latch if you need more protection.

### 4.5 Startup

#### *Initial Startup*

After having mounted the enclosure and wired the unit, the monitor is ready to be started.

Plug in the monitor and turn on the power switch to supply power to the unit. The display will briefly show the WCM model number and then revert to the normal summary display. Scroll through the menus and calibrate the conductivity reading, temperature, and set the control parameters detailed in Section 5, Operation.

To return to the summary display, press the **EXIT** key until you return to this screen. The monitor will automatically return to this screen after 10 minutes.

#### *Normal Startup*

Startup is a simple process once your set points are in memory. Simply check your supply of chemicals, turn on the monitor, calibrate it if necessary and it will start controlling.

### 4.6 Shut Down

To shut the WCM monitor down, simply turn off the power. Programming remains in memory.

## 5.0 OPERATION

These units control continuously while power is applied. Programming is accomplished via the local keypad and display.

To view the top level menu, press any key. The menu structure is grouped by inputs and outputs. Each input has its own menu for calibration and unit selection as needed. Each output has its own setup menu including set points, timer values and operating modes as needed. After ten minutes of inactivity in the menu, the display will return to the summary display. Keep in mind that even while browsing through menus, the unit is still controlling.

### 5.1 Main Menu

The exact configuration of your WCM monitor determines which menus are available as you scroll through the settings. Certain menus are only available if you select certain options. All settings are grouped under the following main menu items.

Conductivity	
Temperature	
Divert	
Time	
4-20mA	Only if 4-20mA option installed
Access Code	
Datalog	Only if advanced USB feature is in model code
Config	Only if advanced USB feature is in model code
Upgrade	

The **NEXT** key travels forward through this list while the **PREV** key travels backwards through the list. Pressing **ENTER** will Enter the lower level menu that is currently displayed.

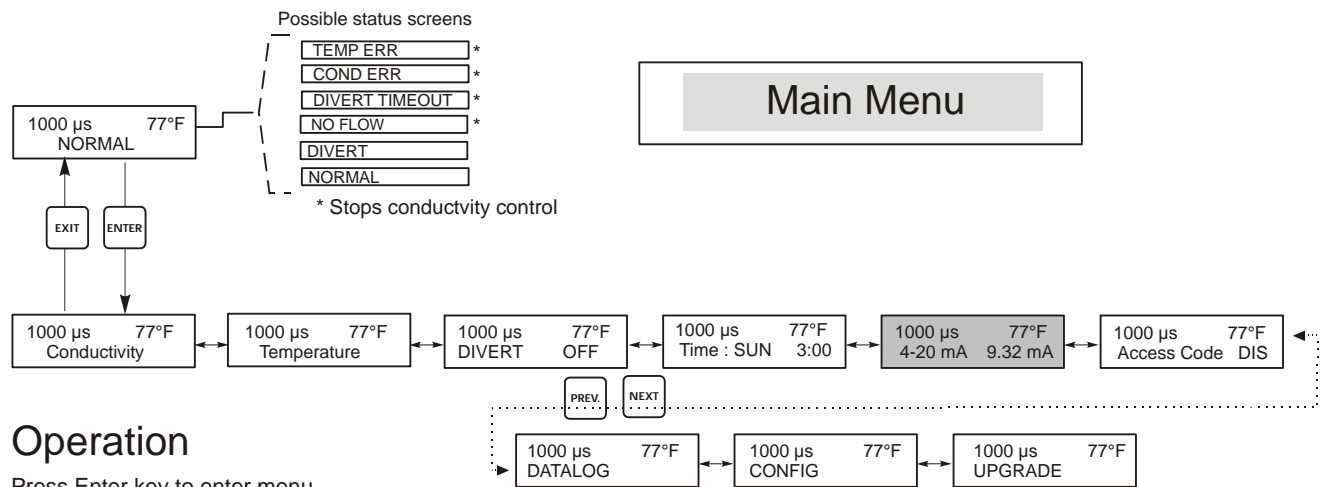

### Operation

Press Enter key to enter menu.

Press Exit key to exit menu.

Blinking fields may be edited with the adjust arrows.

**Legend**  Only appears if option board is installed.

Figure 7 Main Menu

## 5.2 Conductivity Menu

The conductivity menu provides the following settings: Calibration, Self Test, and Unit selection. Additional settings are also discussed below. Refer to figure 8, Conductivity Menu Chart.

<b>Calibrate</b>	To Calibrate the conductivity, use either a hand held meter, or a buffer solution, and adjust the WCM monitor to match. Once Calibrate is entered, the unit continuously displays conductivity readings. Press an arrow key to change the value displayed to match the hand held meter or the buffer solution. You must press ENTER to activate the new calibration. You must press the EXIT key to exit calibration.
<b>Self Test</b>	Press ENTER to begin self test. Press any key to stop. Self Test internally simulates a conductivity sensor and should <i>always</i> give the reading 1000 $\mu\text{S}/\text{cm} \pm 100 \mu\text{S}$ . If it does not, there is a problem with the electronics and the unit should be serviced. If the self test is in the expected range and you have a problem calibrating, then the sensor or its wiring is at fault.
<b>Units</b>	You may choose to display conductivity in $\mu\text{S}/\text{cm}$ or in ppm. Press ENTER and then use the Up and Down arrows to change the units. If you change the units, you will be warned to check your settings. This is important. Set points are not automatically translated from $\mu\text{S}/\text{cm}$ to ppm. If you change the units you will need to change your Alarm settings.
<b>ppm C.F.</b>	This is the ppm Conversion Factor (or multiplier). This is typically 0.666 but can be changed to accommodate various requirements.
<b>RawCond</b>	This menu is for information only and displays the temperature-compensated conductivity reading before the user's calibration has been applied.

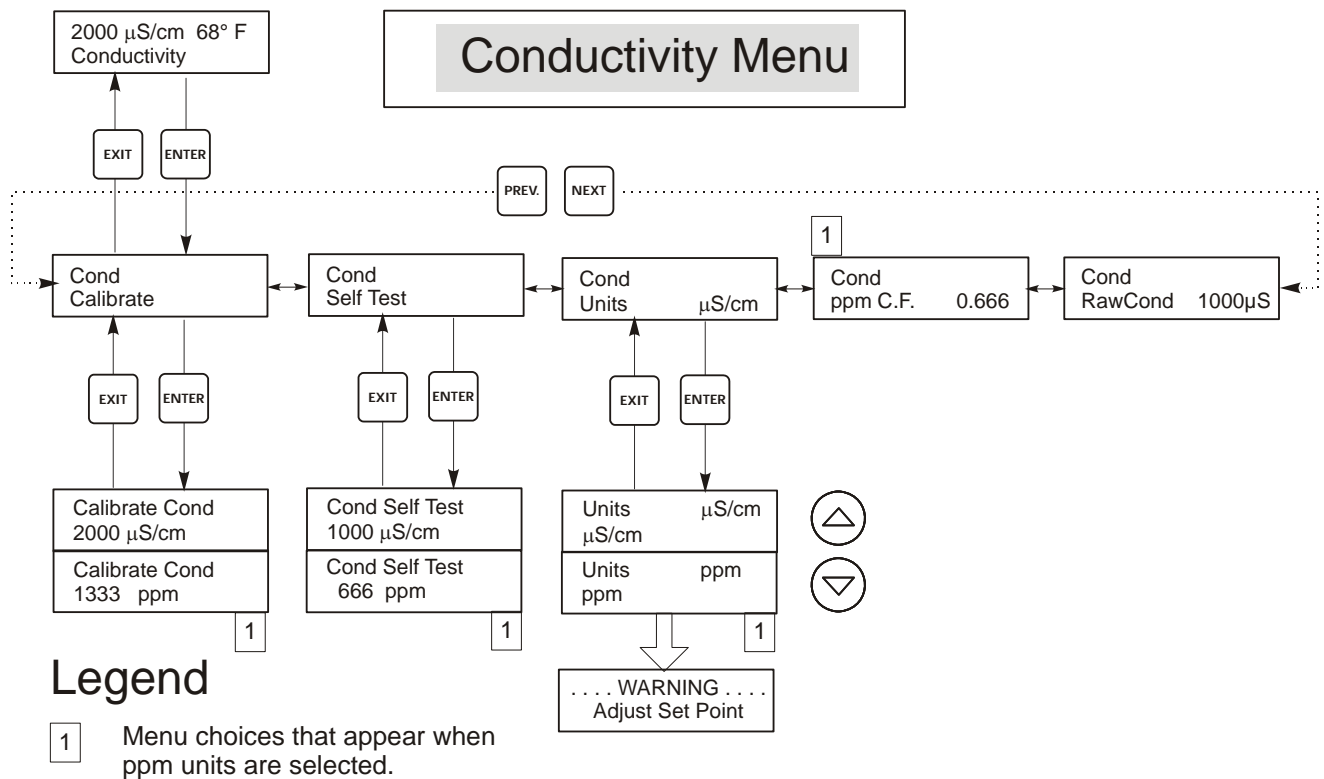

**Operation**

- Press Enter key to enter menu.
- Press Exit key to exit menu.
- Blinking fields may be edited with the adjust arrows.
- Press Enter when modification is complete to return to Conductivity Menu Level.

**Figure 8 Conductivity Menu**



### 5.3 Temperature Menu

The Temperature menu provides the following settings: Calibration, Unit selection. The Temperature menu will be indicated on the display by one of the following:

- Temperature Normal operation
- Temp 70°F Normal operation
- Temp Error Indicates that there is a problem with the temperature input. See Figure 9.

<b>Calibrate</b>	To Calibrate the Temperature, use a thermometer to measure the fluid temperature and adjust the WCM monitor to match. Once Calibrate is entered, the unit continuously displays temperature readings. Press the Up or Down arrow key to change the value displayed to match the thermometer. You must press ENTER to activate the new calibration. You must press the EXIT key to exit calibration.
<b>Man Temp</b>	This menu appears only if no temperature element is connected at power-up. Use the arrow keys to adjust the temperature displayed to match that of the boiler water.
<b>Units</b>	You may choose to display temperature in °C or °F. Press ENTER and the Up or Down Arrow keys to change the temperature units for display.
<b>Mode</b>	Press ENTER and use the UP or DOWN arrow keys to select between Manual Temperature Compensation (used with sensors that do not have a temperature measuring element in them) or Automatic Temperature Compensation. If Automatic is selected, and the temperature element is not detected, the controller will display a Temp Error and revert to Manual Temp Comp until the signal is restored.

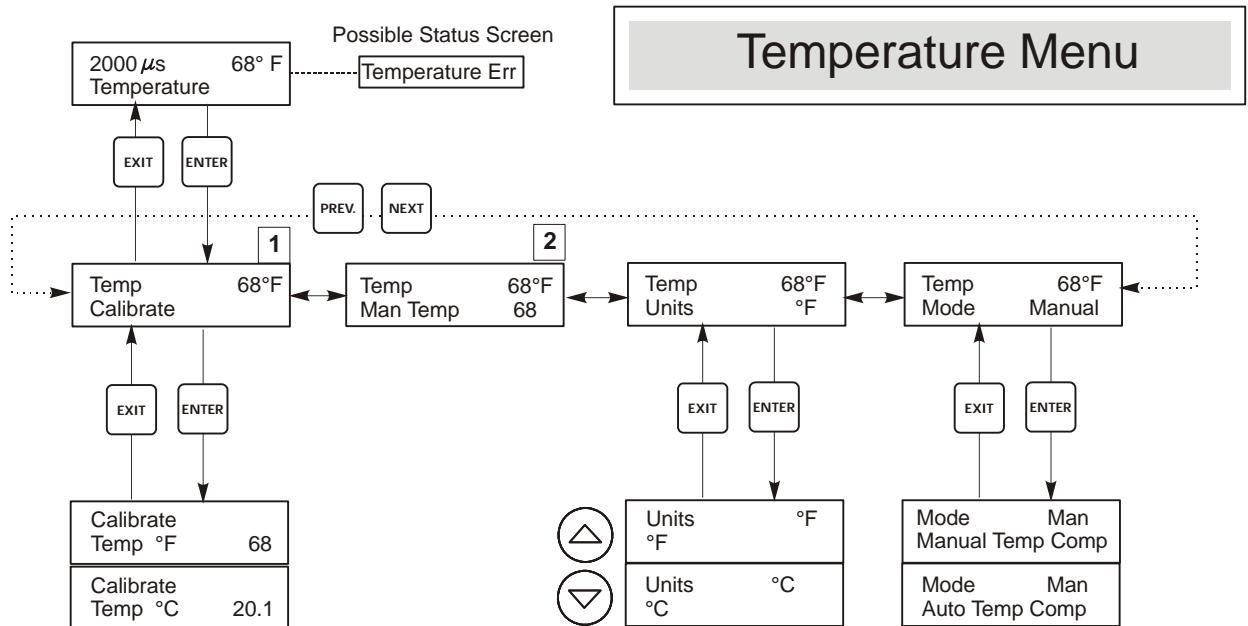

### Legend

- 1 Menu wording that appears when Automatic Temperature Compensation is selected.
- 2 Menu wording that appears when Manual Temperature Compensation is selected.

**Figure 9 Temperature Menu**



## 5.4 Divert Menu

The Divert Menu provides the following settings: Set Point, Dead Band, Control Direction, HOA. The Divert menu will be indicated on the display by one of the following. The 'A' indicates that the output is being controlled automatically.

- Divert A      **OFF**    The first display indicates that the divert output is currently OFF.
- Divert A      **10:00**    The second display indicates the length of time that the Alarm output has been ON.

<b>Set Point</b>	This is the conductivity value at which the diverter valve and alarm output are turned ON. The factory default setting for the WCM monitor is for the alarm output to turn on when the conductivity is higher than the set point. This may be changed at the Control Direction screen.	
<b>Dead Band</b>	This is the conductivity value that when combined with the set point determines when the alarm outputs turn OFF. Assuming that the control direction is set for normal operation (High Set Point) the alarm outputs will turn off when the conductivity drops below the set point minus the Dead Band. For example: The set point is 25 $\mu\text{S}/\text{cm}$ and the Dead Band is 5 $\mu\text{S}/\text{cm}$ . The alarm outputs turn ON when the conductivity reading is greater than 25 but does not turn OFF until the conductivity drops below 20.	
<b>Time Limit</b>	This menu allows you to set a maximum amount of time for the alarm. The limit time is programmed in hours and minutes and can be set between 1 minute and 10 hours. If the time limit is set to zero, then the valve may be open indefinitely. If the maximum time is exceeded, the diverter valve will close and will not re-open until the "Reset Timer" menu is reset by an operator.	
<b>Reset Timer</b>	Only appears if the time limit above has been exceeded. Use the up or down arrow to change "N" to "Y", then press ENTER.	
<b>Control Dir H / L</b>	This allows you to set the Normal (High Set Point) or Inverse (Low Set Point) operation of the outputs. When set to High, the outputs turn on when the conductivity is <i>higher</i> than the set point. When set to Low, the outputs turn on when the conductivity is <i>lower</i> than the set point.	
	<b>High Set Point</b>	<b>Low Set Point</b>
<b>H O A</b>	The "Hand Off Auto" screen allows you to select the operating mode of the alarm outputs. In Hand (manual) mode, the output is turned on immediately for a maximum of 10 minutes. If you walk away the output will return to Auto mode at the end of that time. In Off mode the output will stay Off indefinitely. In Auto mode the output will respond to changes in conductivity based on the set point. The HOA mode of the alarm output is indicated on the alarm status lines.	

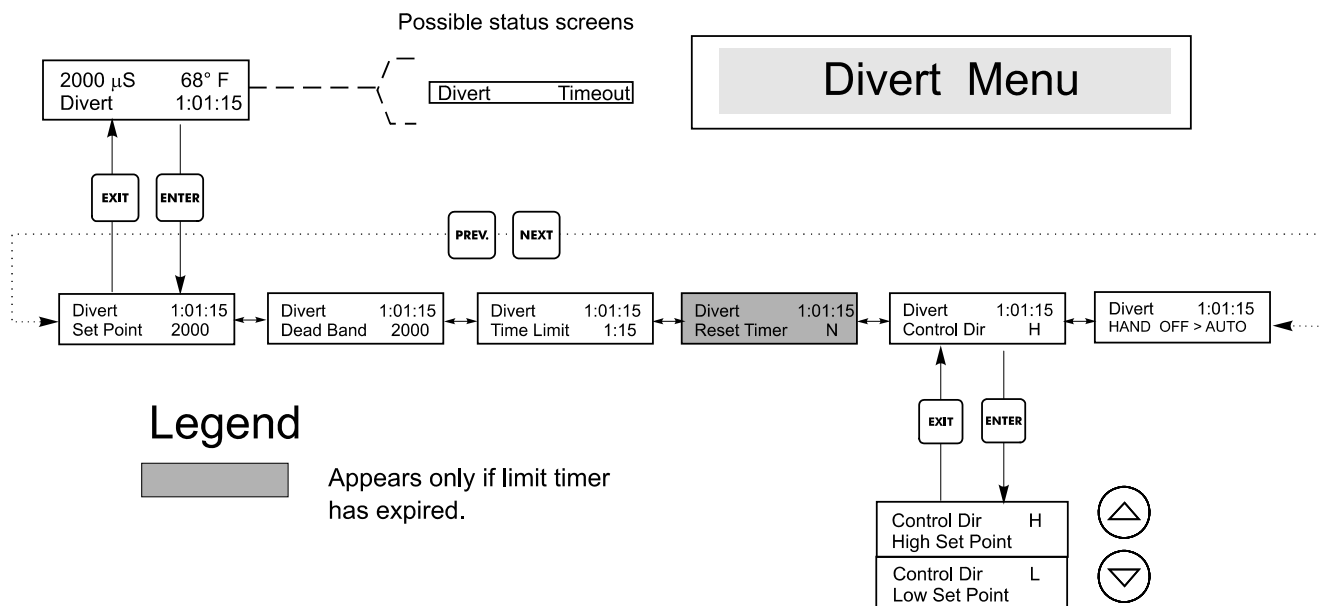

Figure 10 Divert Menu

## 5.5 Time Menu

This menu has only one choice, to set the Time used for Datalogs. This menu will appear as follows:

Time: Mon 10:20

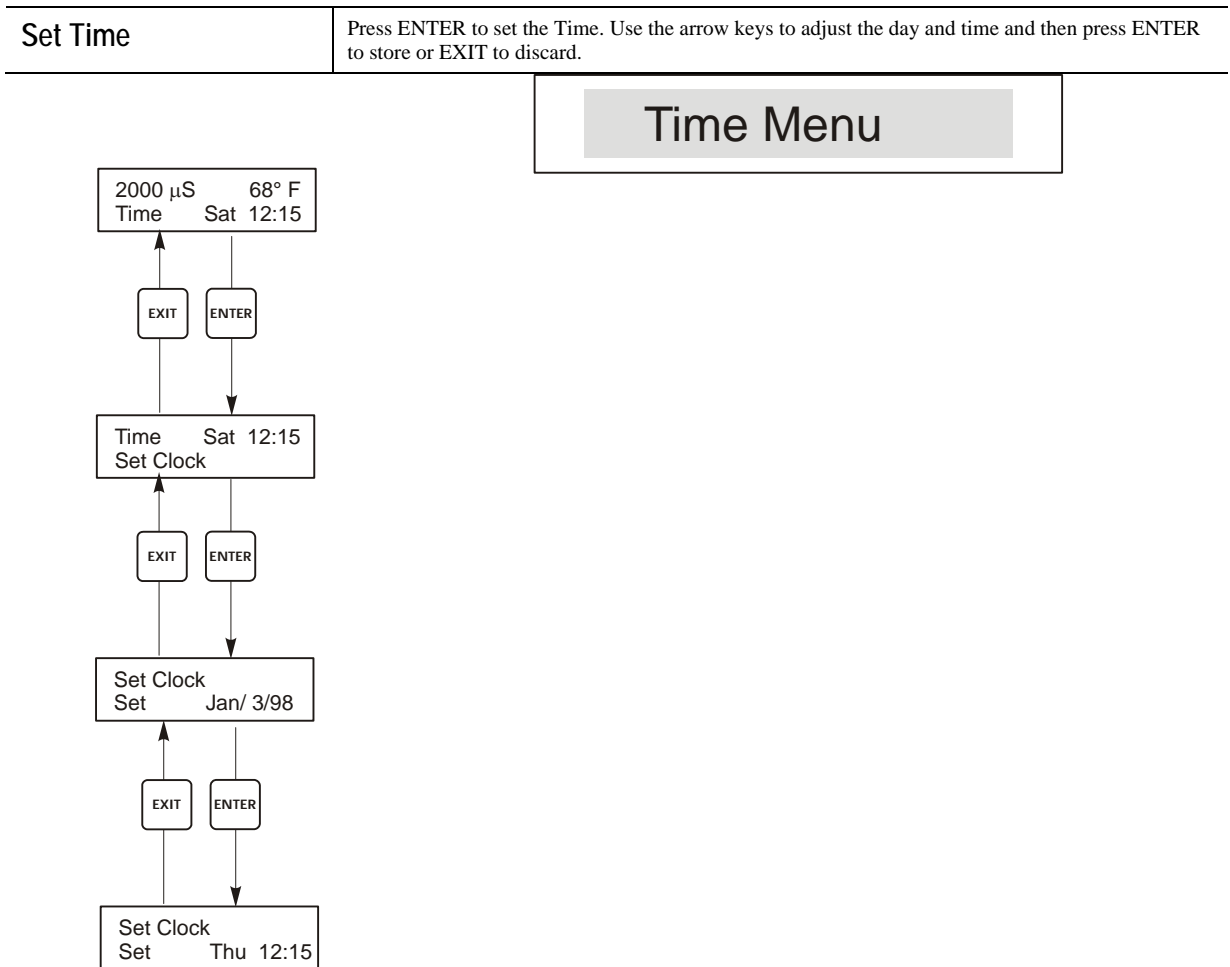

Figure 11 Time Menu

## 5.6 4-20mA Menu

This menu is only available if the 4-20mA output is installed in the monitor. This menu provides for scaling and calibrating the output. The 4-20mA menu screen appears as follows:

4-20mA 9.20mA

This indicates that the current output of the 4-20mA card is 9.20 mA.

Set 4mA Pt	This conductivity setting will correspond to a 4 mA output from the monitor.
Set 20mA Pt	This conductivity setting will correspond to a 20mA output from the monitor.
Calibrate	This will provide fixed 4mA and fixed 20mA outputs to allow you to calibrate connected equipment.

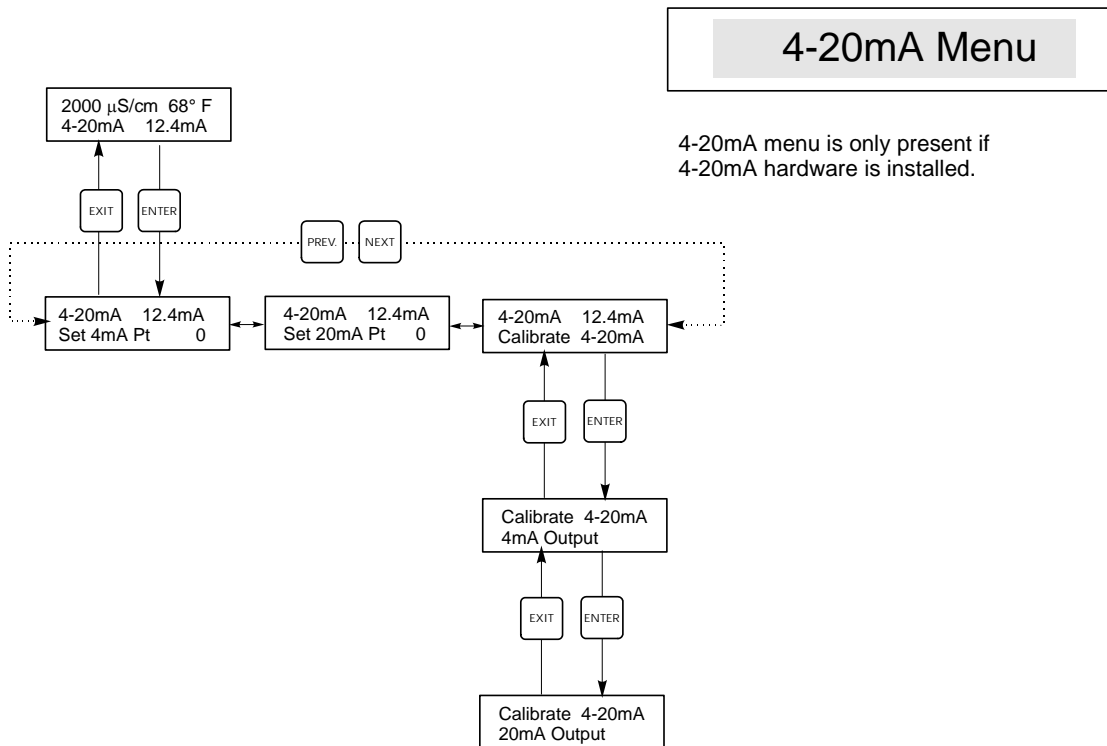

Figure 12 4-20 mA Menu

## 5.7 Access Code Menu

This menu determines whether the access code feature of the monitor is enabled or disabled and allows you to customize the access code to your own value. The access code controls whether or not you are allowed to change the parameters in the monitor. With the access code disabled, any user may change any parameter. With the access code enabled, any user can view any parameter, but cannot change them. Once an attempt is made to change a parameter, the display will prompt the user to enter the access code. If the correct access code is entered, the parameters can be changed. If the wrong access code is entered the parameters cannot be changed. Once the access code has been correctly entered, it will remain valid until there is a period of 10 minutes without a key being pressed. The access code menu will appear as shown below:

The access code menu will appear as shown below:

Access Code	<b>DIS</b>	Indicates that the access code is disabled. No access code is required to change any setting.
Access Code	<b>REQ</b>	Indicates that the access code is required to alter settings.
Access Code	<b>OK</b>	Indicates that the access code is required and has been entered correctly.

<b>Enable N / Y</b>	Press the Up or Down arrow key to change the N to Y and press ENTER to enable the access code feature. If the access code is enabled you must first enter the access code to disable it.
<b>New Value</b>	Press ENTER to display the current access code value and use the arrow keys to change it to any value between 0 and 9999. If the access code has been enabled, you will be prompted to enter the current access code before being allowed to change it. You must remember the access code if you enable it.  The Factory default Access code is 1995. If you change the access code and can't remember it follow this procedure: 1. Turn off power to the monitor. 2. Wait 10 seconds. 3. Press and Hold the UP and DOWN arrow keys while turning on the power. 4. Read the access code on the display. 5. Release the keys, and the access code will disappear.

### Access Code Menu

Any Top Display  
Access Code 0000

The Access Code prompt may appear at any screen in the entire menu structure if the current access code has not been entered by the user. Access code entries will be valid for 10 minutes from the most recent key press.

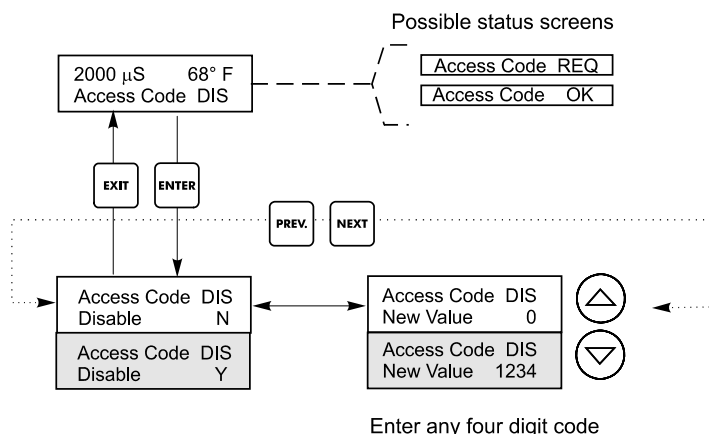

Figure 13 Access Code Menu

## 5.8 Datalog Menu

This menu is available if the data logging option has been purchased. This is indicated in the model code by the letter U at the end of the model code. This menu allows you to save data from the controller to a USB flash drive.

The controller has four logs, the Current Datalog, the Backup Datalog, the Event Log, and the Reset Log. All files are in a CSV format that may be opened in a spreadsheet such as Microsoft Excel.

- Current Datalog** Contains the following data taken at 10 minute intervals:  
 Conductivity  
 Temperature
- When the current datalog is downloaded to a USB stick, it is erased and a new log file is started. If the current datalog is not downloaded before it reaches its maximum size (at least 60 days of data) the oldest data is overwritten by the newest data.
- Backup Datalog** Contains the same data as the current log but it is never erased. When the backup log reaches its maximum size (at least 60 days of data), the oldest data is overwritten by the newest data.
- Event Log** Contains columns for each relay and flow switch input, as well as the date and time. Each time any of these change state, the date and time is updated and it will show a 1 if the relay is on and 0 if it is off, and a 1 if the flow switch indicates no flow, 0 if there is flow. Tens of thousands of events will be recorded before the oldest data is overwritten by the newest, the number varying with the controller's configuration.
- Reset Log** Consists of time stamps of when power was lost, when it was returned, and the cause of the reset.

<b>Current or Backup Datalog</b>	<p>Place a USB flash drive with at least 10 MB capacity into the USB port on the front panel of the controller. Press the Enter key to download the file from the controller to the disk. The file name for the Current Datalog will be Datalog&lt;serial number&gt;&lt;date&gt;&lt;time&gt;.csv using the date and time it was downloaded. The file name for the Backup Datalog will be Datalog&lt;serial number&gt;&lt;date&gt;&lt;time&gt;.csv using the date and time it was created.</p> <p>The controller will display the progress of the file download process. If the file was successfully copied to the USB disk the controller will display Transfer Success.</p>	
<b>Copy Event Log</b>	<p>Place a USB flash drive with at least 10 MB capacity into the USB port on the front panel of the controller. Press the Enter key to download the file from the controller to the stick. The file name will be Eventlog&lt;serial number&gt;&lt;date&gt;&lt;time&gt;.csv.</p> <p>The controller will display the progress of the file download process. If the file was successfully copied to the USB disk the controller will display Transfer Success, otherwise Transfer Fail 1.</p>	
<b>Copy Reset Log</b>	<b>Transfer Success</b>	<b>Transfer Fail 1</b>
	<b>Transfer Success</b>	<b>Transfer Fail 1</b>

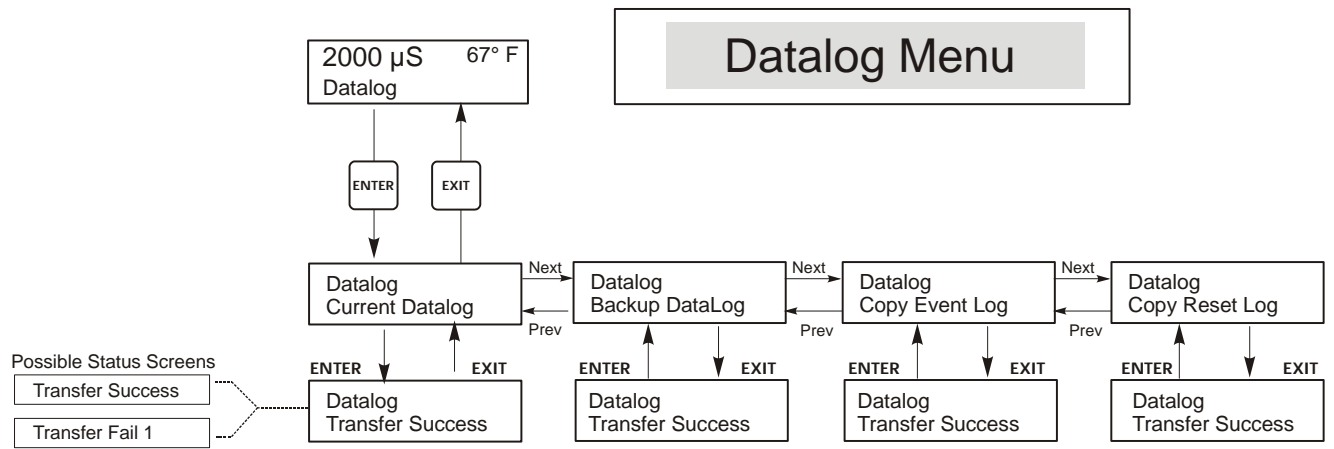

**Figure 14 Datalog Menu**

## 5.9 Config Menu

This menu allows you to export a file that contains all of the set points in the monitor to a USB flash disk drive, and then later import the set points into another monitor.

<b>Export Config</b>	Place a USB flash drive with at least 10 MB capacity into the USB port on the front panel of the monitor. Press the Enter key to export the configuration file from the monitor to the stick. The file name will be UCF.ini. If you are exporting files with different set points you may rename the file to something that describes it, as long as it has an ini extension. The monitor will display the progress of the file download process. If the file was successfully exported to the USB disk the monitor will display Transfer Success, otherwise Transfer Fail 1.	
	<b>Transfer Success</b>	<b>Transfer Fail 1</b>
<b>Import Config</b>	Place a USB flash drive that contains only one configuration file stored on the root directory of the stick into the USB port on the front panel of the monitor. Press the Enter key to import the configuration file from the stick to the monitor. The file name must have an ini extension in its name. The monitor will display the progress of the file import process. If the file was successfully imported from the USB disk the monitor will display one of the messages below:	
	<b>Import Failure</b>	Indicates that there were problems connecting to or accessing the USB stick.
	<b>Import Success: Any key to reboot</b>	The configuration file import succeeded and will be ready for use after reboot.
	<b>File Open Failed</b>	A config file could not be found on the USB stick or the USB stick file system could not be accessed.
	<b>File Read Failed</b>	The config file is too short (incomplete) or empty.
	<b>Invalid CFG File</b>	The imported file is not a valid config file.
	<b>Invalid Model</b>	The imported config file is not for this monitor model.
	<b>Wrong SW Version</b>	The version of the imported config file is not compatible with this monitor software version.
	<b>Corrupt CFG File</b>	The imported config file is corrupt. (The checksum failed.)
	<b>Wrong file Size</b>	The size of the imported config file is wrong.

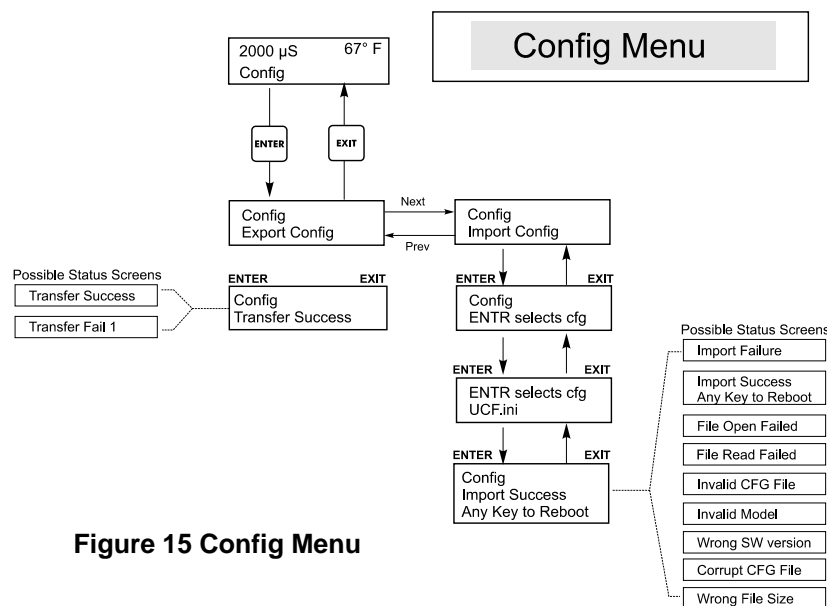

Figure 15 Config Menu

## 5.10 Upgrade Menu

This menu is used to upgrade the software to a newer version. If a new version of the software is available, an upgrade file will be posted on our web site. Save this file to a USB flash disk drive. It needs to be the only executable (.exe file extension) file stored on the root directory of the stick. Press the Enter key to import the software upgrade file from the stick to the monitor.

The monitor will display the progress of the file import process. If the file was successfully imported from the USB disk the monitor will display Transfer Success. The monitor will automatically reboot and come up with the new software installed.

<b>Upgrade</b>	The monitor will display the progress of the file import process. If the file was successfully imported from the USB disk the monitor will display Transfer Success. The monitor will automatically reboot and come up with the new software installed. If the software upgrade fails, you will see one of the following messages:	
	<b>UpgradFileInvald</b>	The file found on the USB stick is for the wrong product, or is corrupt. Try getting the correct upgrade file and make sure it's the only upgrade file on the stick.
	<b>No Upgrade File</b>	There is no upgrade file stored on the stick, or the file is named incorrectly.
	<b>CorrptUpgradFile</b>	Try getting a new copy of the file.
	<b>Flash Failure</b>	The flash memory on the processor board has a problem. Repair or replace the front panel assembly.

To check that it was successful, turn off power to the monitor, then press the Enter key while turning power on. The monitor will show the software version, which should match the name of the upgrade file that you used.

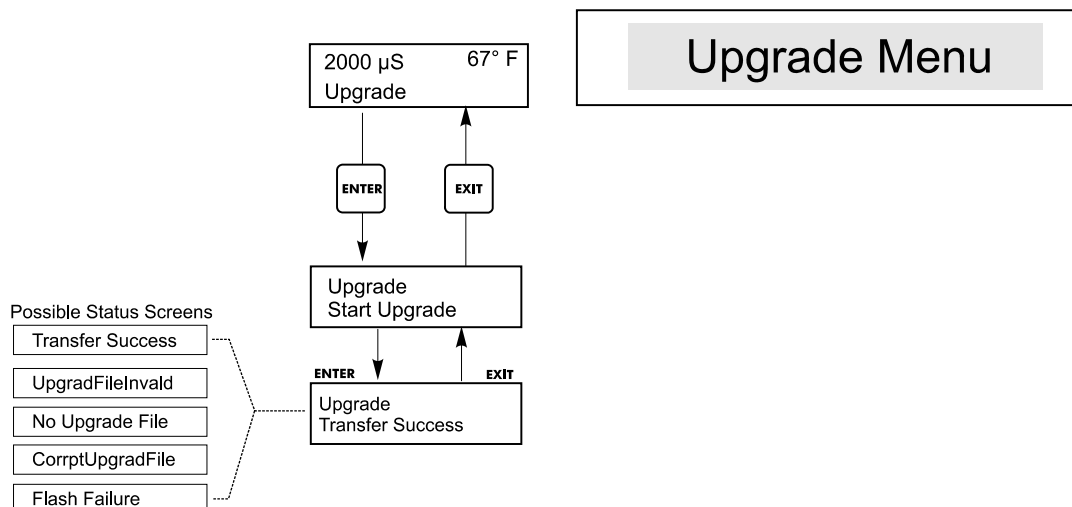

**Figure 16 Upgrade Menu**



## 6.0 MAINTENANCE

---

The WCM monitor itself requires very little maintenance. Wipe with a damp cloth. Do not spray down the monitor unless the enclosure door is closed and latched.

### 6.1 Electrode Cleaning

NOTE: The monitor must be recalibrated after cleaning the electrode.

#### *Frequency*

The electrode should be cleaned periodically. The frequency required will vary by installation. In a new installation, it is recommended that the electrode be cleaned after two weeks of service. To determine how often the electrode must be cleaned, follow the procedure below.

1. Read and record the conductivity.
2. Remove, clean and replace the conductivity electrode in the process.
3. Read conductivity and compare with the reading in step 1 above.

If the variance in readings is greater than 5%, increase the frequency of electrode cleaning. If there is less than 5% change in the reading, the electrode was not dirty and can be cleaned less often.

#### *Cleaning Procedure*

The electrode can normally be cleaned using a cloth or paper towel and a mild cleaning solution such as 409® cleanser. Occasionally an electrode may become coated with various substances which require a more vigorous cleaning procedure. Usually the coating will be visible, but not always.

### 6.2 Replacing the Fuses



**CAUTION:** Disconnect power to the monitor before opening front panel!

Locate the fuses on the circuit board at the back of the monitor enclosure. (See figure 3.) Gently remove the old fuse from its retaining clip and discard. Press the new fuse into the clip, secure the front panel of the monitor and return power to the unit.

Warning: Use of non-approved fuses can affect product safety approvals. Fuse ratings depend on monitor power rating. Specifications are shown below. To insure product safety certifications are maintained, it is recommended that a Walchem fuse be used.

F1 Fuse	Walchem P/N	F2 Fuse	Walchem P/N
5 x 20 mm, 1.0A, 250V	103163	5 x 20 mm, 6A, 250V	102834

## 7.0 TROUBLESHOOTING



**CAUTION:** Disconnect power to the monitor before opening front panel!

Troubleshooting and repair of a malfunctioning monitor should only be attempted by qualified personnel using caution to ensure safety and limit unnecessary further damage. Contact the factory.

### 7.1 Error Messages

#### **TEMP ERROR**

This error condition indicates that the temperature signal from the conductivity electrode is no longer valid. The controller will revert to manual temperature compensation.

Possible Cause	Correction Action
Green or white electrode wire disconnected.	Reconnect.
Faulty electrode.	Replace electrode. Revert to manual temperature compensation by cycling power off and on.

#### **SENSOR ERROR**

This error condition will stop conductivity control. It indicates that the conductivity signal from the electrode is no longer valid. This prevents controlling based upon a false conductivity reading.

Possible Cause	Correction Action
Back or red electrode wire shorted.	Disconnect short.
Faulty electrode.	Replace electrode.
Faulty controller.	Verify via failed self test.

#### **DIVERT TIMEOUT**

This error condition will stop conductivity control. It is caused by the output being activated for longer than the programmed Divert Time Limit.

Possible Cause	Corrective Action
Programmed value too low for normal conditions.	Increase Divert Time Limit.
Diverter flow rate too low.	Check for clogged strainer. Check for insufficient pressure differential.
Diverter valve not opening.	Check for faulty diverter valve. Check diverter valve wiring. Check controller relay.

#### **NO FLOW**

This error message will appear if the flow/no flow switch closure is opened. The error message will be displayed and the alarm relay will trip. The conductivity is updated but all outputs are deactivated.

Possible Cause	Corrective Action
No flow	Check recirculating pump, valves, etc.
Faulty flow switch/cable	Check for open circuit. Disconnect flow switch and short the input with a piece of wire. If "no flow" message disappears, then switch or cable may be faulty.
Insufficient pressure drop through sample stream	Check piping.

## CAL FAIL

The controller allows a maximum of  $\pm 50\%$  correction to the conductivity reading. This is a cumulative correction factor which means that if at one time the electrode is calibrated by 30%, the next time it is calibrated it will only accept an adjustment of +20% before reporting a Cal Fail.

The most likely problem is that the electrode needs to be cleaned. Refer to section 6.1.

## 7.2 Conductivity Readout Does Not Change

If the readout is stuck at or near zero:	
Possible Cause	Corrective Action
Dry electrode	Check for flow through system.
Electrode is disconnected.	Check wiring to electrode. Go to self-test menu, as described in section 5.2. If readout changes to 900-1100, the problem is with electrode or connections. See section 7.2. If still at zero, problem is with controller. Consult the factory.
Electrode is coated.	Clean off non-conductive coating with a suitable solvent.
If the readout is stuck at another number:	
Possible Cause	Corrective Action
Dirty or faulty electrode	Evaluate electrode (section 7.2).
Stagnant sample	Check system for proper flow.

## 7.3 Procedure for Evaluation of Conductivity Electrode

Can be used for troubleshooting low conductivity, high conductivity, conductivity stuck at 0, and/or conductivity stuck at a number other than 0.

Try cleaning the electrode first (refer to Sect. 6.1).

To find out if the electrode or the monitor is faulty, step through the Self-Test menu, as described in section 5.2. The display should read  $1000 \mu\text{S} \pm 100 \mu\text{S}/\text{cm}$ . This indicates that the monitor is OK and the problem is in the electrode or its connections. If it does not read  $1000 \mu\text{S}/\text{cm} \pm 100 \mu\text{S}/\text{cm}$ , return the control module for repair.

To check the electrode, check the electrode connections to the terminal strip (refer to Figure 3). Make sure that the correct colors go to the correct terminals, and that the connections are tight. Restore power and see if the conductivity is back to normal. If not, replace the electrode.

## **8.0 SERVICE POLICY**

---

The WCM series Condensate Monitor has a 2-year warranty on electronic components and a 1-year warranty on mechanical parts (keypad, terminal strip and relays).

We stock circuit boards for immediate exchange after we have isolated the cause of the problem.

Factory authorized repairs that are received by next-day-air will be returned within 24 hours. Normal priority for returns is two weeks.

Out of warranty repairs or circuit board exchanges are done on a flat fee basis after the warranty is expired.

## Model Code

**WCM400**

-

Voltage

Output

Sensor

U (USB)

### **VOLTAGE**

1 = 120 VAC, prewired

5 = Hardwired, cable glands

### **OUTPUT**

N = No data output

4 = Isolated 4-20 mA output

### **SENSOR**

N = No electrode

5 = Standard electrode (up to 250 psi)

### **USB FEATURES**

U = Integrated datalogging, event/reset logging, and configuration file import/export

FIVE BOYNTON ROAD  
TEL: 508-429-1110

HOPPING BROOK PARK  
FAX: 508-429-7433

HOLLISTON, MA 01746 USA  
Web: [www.walchem.com](http://www.walchem.com)