

Conductivity, pH/ORP & Disinfection



W900 Series Water Treatment Controllers

Enjoy unparalleled versatility and powerful programming for complete control of chemical metering pumps and valves in a broad range of water treatment applications.

KEY BENEFITS

- Large touchscreen display with icon based programming makes setup easy
- Universal sensor input provides extraordinary flexibility; the same controller can be used with almost any type of sensor needed
- Four I/O slots allow complete flexibility in adding sensors, analog inputs, analog outputs and LPR corrosion sensors
- Multiple language support allows simple setup
- Eight relay control outputs allow the controller to be used in more applications
- Eight virtual inputs and eight virtual outputs
- Economical wall-mount package for easy installation
- On-screen and web page graphing of sensor values and control output status
- Complete flexibility in the function of each relay
- Ethernet or WiFi for remote access via the Internet, LAN, or optional BACnet or Modbus/TCP
- Datalogging
- Emailing Alarm messages, Datalog, Graph, or System Summary reports



Scan QR code with your
smartphone camera
for more details!

W A L C H E M

IWAKI America Inc.

SPECIFICATIONS

INPUTS

Power

100-240 VAC, 50 or 60 Hz, 13A max Fuse: 6.3 Amp

Sensor Input Signals (0-8 depending on model code)

Contacting Conductivity: 0.01, 0.1, 1.0, or 10.0 cell constant, or

Electrodeless Conductivity or

Disinfection or

Amplified pH, ORP, or Ion Selective Electrode which requires a preamplified signal. $\pm 5\text{VDC}$ power available for external preamps. Walchem WEL or WDS series pH/ORP sensors recommended.

Each sensor input card contains a temperature input.

Temperature: 100 or 1000 ohm RTD, 10K or 100K Thermistor

Analog (4-20 mA) Sensor Input (0-24 depending on model code)

2-wire loop powered and self-powered transmitters supported

3-wire and 4-wire transmitters supported

All Channels fully isolated, input and power

Channel 1, 130 ohm input resistance, Channel 2-6, 280 ohm input resistance

Available Power: Isolated 24 VDC $\pm 15\%$ supply per channel. 1.5 W (62.5 mA maximum for each channel)

Digital Input Signals (12):

State-Type Digital Inputs

Electrical: Optically isolated and providing an electrically isolated 12V power with a nominal 2.5 mA current when the digital input switch is closed. Typical response time: < 2 seconds. Devices supported: Any isolated dry contact (i.e. relay, reed switch). Types: DI State

Low Speed Counter-Type Digital Inputs

Electrical: Optically isolated and providing an electrically isolated 12V power with a nominal 2.5 mA current when the digital input switch is closed, 0-20 Hz, 25 msec minimum width. Devices supported: Any device with isolated open drain, open collector, transistor or reed switch.

Types: Contacting Flowmeter

High Speed Counter-Type Digital Inputs

Electrical: Optically isolated and providing an electrically isolated 12V power with a nominal 2.5 mA current when the digital input switch is closed, 0-500 Hz, 1.0 msec minimum width. Devices supported: Any device with isolated open drain, open collector, transistor or reed switch. Types: Paddlewheel Flowmeter

OUTPUTS

Powered Mechanical Relays (0-8 model code dependent)

Pre-powered on circuit board switching line voltage

Four relays are fused together as one group, total current must not exceed 6.3A (resistive), 1/8 HP (93W)

Dry Contact Mechanical Relays (0-8 model code dependent)

6 A (resistive), 1/8 HP (93W)

Dry contact relays are not fuse protected.

Pulse Outputs (0-4 model code dependent)

Opto-isolated, solid-state relay, 200mA, 40V DC

VLOWMAX = 0.05V @ 18mA

4 - 20 mA (0-16 model code dependent)

Internally powered, 15VDC, Fully isolated

600 ohm max resistive load

Resolution 0.0015% of span

Accuracy $\pm 0.5\%$ of reading

MEASUREMENT PERFORMANCE

	Range	Resolution	Accuracy
0.01 Cell Contacting Conductivity	0-300 $\mu\text{S}/\text{cm}$	0.01 $\mu\text{S}/\text{cm}$, 0.0001 mS/cm, 0.001 mS/m, 0.0001 S/m, 0.01 ppm	$\pm 1\%$ of reading
0.1 Cell Contacting Conductivity	0-3,000 $\mu\text{S}/\text{cm}$	0.1 $\mu\text{S}/\text{cm}$, 0.0001 mS/cm, 0.01 mS/m, 0.0001 S/m, 0.1 ppm	$\pm 1\%$ of reading
1.0 Cell Contacting Conductivity	0-30,000 $\mu\text{S}/\text{cm}$	1 $\mu\text{S}/\text{cm}$, 0.001 mS/cm, 0.1 mS/m, 0.0001 S/m, 1 ppm	$\pm 1\%$ of reading
10.0 Cell Contacting Conductivity	0-300,000 $\mu\text{S}/\text{cm}$	10 $\mu\text{S}/\text{cm}$, 0.01 mS/cm, 1 mS/m, 0.001 S/m, 10 ppm	$\pm 1\%$ of reading
pH	-2 to 16 pH units	0.01 pH units	$\pm 0.01\%$ of reading
ORP/Ion Selective Electrode	-1500 to 1500 mV	0.1 mV	± 1 mV
Disinfection sensors	-2000 to 1500 mV	0.1 mV	± 1 mV
	0 - 2 ppm to 0 - 20,000 ppm	Varies with range and slope	Varies with range and slope
Electrodeless Conductivity	500 - 12,000 $\mu\text{S}/\text{cm}$	1 $\mu\text{S}/\text{cm}$, 0.01 mS/cm, 0.1 mS/m, 0.001 S/m, 1 ppm	$\pm 1\%$ of reading
	3,000-40,000 $\mu\text{S}/\text{cm}$	1 $\mu\text{S}/\text{cm}$, 0.01 mS/cm, 0.1 mS/m, 0.001 S/m, 1 ppm	$\pm 1\%$ of reading
	10,000-150,000 $\mu\text{S}/\text{cm}$	10 $\mu\text{S}/\text{cm}$, 0.1 mS/cm, 1 mS/m, 0.01 S/m, 10 ppm	$\pm 1\%$ of reading
	50,000-500,000 $\mu\text{S}/\text{cm}$	10 $\mu\text{S}/\text{cm}$, 0.1 mS/cm, 1 mS/m, 0.01 S/m, 10 ppm	$\pm 1\%$ of reading
	200,000-2,000,000 $\mu\text{S}/\text{cm}$	100 $\mu\text{S}/\text{cm}$, 0.1 mS/cm, 1 mS/m, 0.1 S/m, 100 ppm	$\pm 1\%$ of reading
Temperature	23 to 500°F (-5 to 260°C)	0.1°F (0.1°C)	$\pm 1\%$ of reading within range

Temp. °C	Range Multiplier%
0	181.3
10	139.9
15	124.2
20	111.1
25	100.0
30	90.6
35	82.5
40	75.5
50	64.3
60	55.6
70	48.9

Temp. °C	Range Multiplier%
80	43.5
90	39.2
100	35.7
110	32.8
120	30.4
130	28.5
140	26.9
150	25.5
160	24.4
170	23.6
180	22.9

Note: Conductivity ranges above apply at 25°C. At higher temperatures, the range is reduced per the range multiplier chart.



MECHANICAL (CONTROLLER)

Enclosure Material	Polycarbonate
Enclosure Rating	NEMA 4X (IP65)
Dimensions	12.2W x 13.8H x 5.4D" (310 x 351 x 137 mm)
Display	320 x 240 pixel monochrome backlit display with touchscreen
Ambient Temperature	-4 to 122°F (-20 to 50°C)
Storage Temperature	-4 to 176°F (-20 to 80°C)
Humidity	10 to 90%, non-condensing

AGENCY CERTIFICATIONS

Safety: UL 61010-1:2012, 3rd Edition+Rev:2016
 CSA C22.2 No.61010-1:2012, 3rd Ed.+U1;U2
 IEC 61010-1:2010 3rd Edition
 EN 61010-1:2010 3rd Edition
 BS EN 61010-1:2010+A1:2019

EMC: IEC 61326-1:2012
 EN 61326-1:2013
 BS EN 61326-1:2013

Note: For EN61000-4-6, EN61000-4-3 the controller met performance criteria B. This equipment is suitable for use in establishments other than domestic and those directly connected to a low voltage (100-240 VAC) power supply network which supplies buildings used for domestic purposes.

MECHANICAL (SENSORS) (*see graph)

Sensor	Pressure	Temperature	Materials	Process Connections
Electrodeless conductivity	0-150 psi (0-10 bar)*	CPVC: 32-158°F (0 to 70°C)* PEEK: 32-190°F (0 to 88°C)	CPVC, FKM in-line o-ring PEEK, 316 SS in-line adapter	1" NPTM submersion 2" NPTM in-line adapter
pH	0-100 psi (0-7 bar)*	50-158°F (10-70°C)*	CPVC, Glass, FKM o-rings, HDPE, Titanium rod, glass-filled PP tee	1" NPTM submersion 3/4" NPTF in-line tee
ORP	0-100 psi (0-7bar)*	32-158°F (0-70°C)*		
Contacting conductivity (Condensate)	0-200 psi (0-14 bar)	32-248°F (0-120°C)	316SS, PEEK	3/4" NPTM
Contacting conductivity Graphite (Cooling Tower)	0-150 psi (0-10 bar)*	32-158°F (0-70°C)*	Graphite, Glass-filled PP, FKM o-ring	3/4" NPTM
Contacting conductivity SS (Cooling Tower)	0-150 psi (0-10 bar)*	32-158°F (0-70°C)*	316SS, Glass-filled PP, FKM o-ring	3/4" NPTM
Contacting conductivity (Boiler)	0-250 psi (0-17 bar)	32-401°F (0-205°C)	316SS, PEEK	3/4" NPTM
Contacting conductivity (High Pressure Tower)	0-300 psi (0-21 bar)*	32-158°F (0-70°C)*	316SS, PEEK	3/4" NPTM
pH (High Pressure)	0-300 psi (0-21 bar)*	32-275°F (0-135°C)*	Glass, Polymer, PTFE, 316SS, FKM	1/2" NPTM gland
ORP (High Pressure)	0-300 psi (0-21 bar)*	32-275°F (0-135°C)*	Platinum, Polymer, PTFE, 316SS, FKM	1/2" NPTM gland
Extended pH Range Free Chlorine/Bromine	0-14.7 psi (0-1 bar)	32-113°F (0-45°C)		
Chlorine Dioxide	0-14.7 psi (0-1 bar)	32-122°F (0-50°C)		
Corrosion	0-150 psi (0-10 bar)	32-158°F (0-70°C)*	Glass-filled PP, FKM o-ring	3/4" NPTM
Flow switch manifold	0-150 psi (0-10 bar) up to 100°F (38°C)* 0-50 psi (0-3 bar) at 140°F (60°C)	32-140°F (0-60°C)*	GFRPP, PVC, FKM, Isoplast	3/4" NPTF
Flow switch manifold (High Pressure)	0-300 psi (0-21 bar)*	32-158°F (0-70°C)*	Carbon steel, Brass, 316SS, FKM	3/4" NPTF
Little Dipper 2	0-100 psi (0-7 bar)*	32-122°F (0-50°C)*	PVC, GRFP, FKM	3/4" NPTF in-line tee
Pyxis	0-100 psi (0-7 bar)*	40-104°F (4-40°C)*	CPVC, Quartz, FKM	3/4" NPTF in-line tee

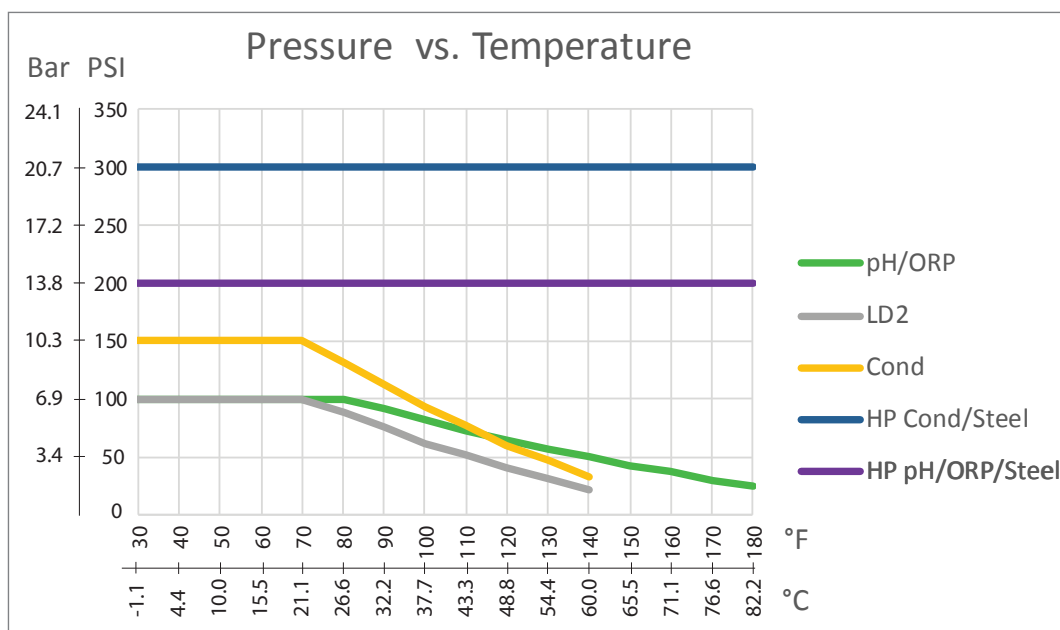

MODEL CODE

W	CT	900P	AADE	W	M	S	ANNNN
Label	Base	Relays/Wiring	I/O Module#1-4	WiFi	Protocol	Sensor Mounting	Sensors #1-5
W	IN	900P	AADE	W	M	S	ANNNN
Label	Base	Relays/Wiring	I/O Module#1-4	WiFi	Protocol	Sensor Mounting	Sensors #1-5
W	BL	900P	AADE	W	M	ANNNNN	
Label	Base	Relays/Wiring	I/O Module#1-4	WiFi	Protocol	Sensors #1-6	

LABEL

W	Walchem
---	---------

BASE

CT	Cooling Tower
BL	Boiler
IN	pH, Disinfection, Conductivity

RELAYS/WIRING

8 powered relays	
900H	Hardwired
900P	Prewired with USA power cord and 8 pigtails
900D	Prewired with DIN power cord, no pigtails
900B	Prewired with Brazilian power cord, no pigtails
7 powered 1 dry relays	
910H	Hardwired
910P	Prewired with USA power cord and 7 pigtails
910D	Prewired with DIN power cord, no pigtails
910B	Prewired with Brazilian power cord, no pigtails
2 opto 6 dry relays	
920H	Hardwired
920P	Prewired with USA power cord and two 20 ft. pulse cables
920D	Prewired with DIN power cord, no pigtails
920B	Prewired with Brazilian power cord, no pigtails
4 powered 4 dry relays	
930H	Hardwired
930P	Prewired with USA power cord and 4 pigtails
930D	Prewired with DIN power cord, no pigtails
930B	Prewired with Brazilian power cord, no pigtails
4 opto 4 dry relays	
940H	Hardwired
940P	Prewired with USA power cord and four 20 ft. pulse cables
940D	Prewired with DIN power cord, no pigtails
940B	Prewired with Brazilian power cord, no pigtails
4 opto 4 powered relays	
950H	Hardwired
950P	Prewired with USA power cord, 4 pigtails and four 20 ft. pulse cables
950D	Prewired with DIN power cord, no pigtails
950B	Prewired with Brazilian power cord, no pigtails
2 opto 6 powered relays	
960H	Hardwired
960P	Prewired with USA power cord, 6 pigtails, two 20 ft. pulse cables)
960D	Prewired with DIN power cord, no pigtails
960B	Prewired with Brazilian power cord, no pigtails
8 dry relays	
970H	Hardwired
970P	Prewired with USA power cord, no pigtails
970D	Prewired with DIN power cord, no pigtails
970B	Prewired with Brazilian power cord, no pigtails

I/O MODULES #1-4 (must be in alphabetical order)

N	No input output module
A	Dual Sensor Inputs
B	Dual Analog Inputs
C	Four Analog Inputs
D	Six Analog Inputs
E	Dual Analog Inputs + Four Analog Outputs
F	Dual Analog Outputs
G	Four Analog Outputs
H	Dual Corrosion Inputs

WiFi

N	None
W	Single Connection, WiFi only
D	Dual Connection, Ethernet and WiFi

COMMUNICATIONS PROTOCOL

N	None
M	Modbus TCP and BACnet

SENSOR MOUNTING

N	None
S	Submersion
I	Inline
L	Loose flow switch manifold
P	Flow switch manifold on panel
F	Loose high pressure flow switch manifold
H	High Pressure flow switch manifold on panel*
S	Submersion
I	Inline
L	Loose flow switch manifold
P	Flow switch manifold on panel

SENSORS #1-5 (must be in alphabetical order)

Only one sensor of the same type can be selected for any manifold mounting style.

N	None
A	Graphite/PP cooling tower contacting conductivity
B	316SS/PP cooling tower contacting conductivity
C	Cooling tower, electrodeless conductivity
D	High pressure conductivity
E	Makeup conductivity
F	Flat pH
G	High pressure pH
H	Rod ORP
I	Flat ORP
J	High pressure ORP
K	Chlorine**
L	ClO ₂ **
M	Little Dipper**
O	One Corrosion Sensor (electrodes purchased separately)**
P	Pyxis PTSA**
R	Two Corrosion Sensors (electrodes purchased separately)**
S	Disinfection, No Sensor
T	Pyxis Polymer**
U	Pyxis PTSA+Polymer**
A	External Preamp
B	Flat pH with ATC
C	Disinfection, no sensor
D	PEEK electrodeless
E	CPVC electrodeless
F	CCond, K=1.0, 100psi
G	CCond, K=0.1, 100psi
H	CCond, K=10, 100psi
I	CCond, K=0.01, 100psi
J	CCond, K=1.0, 200psi
K	CCond, K=0.1, 200psi
L	CCond, K=10, 200psi
M	CCond, K=0.01, 200psi

* If a high pressure manifold is selected, only Hi P sensors and Makeup available.

** Dipper, Pyxis, Chlorine, ClO₂, Corrosion sensors NOT available with Submersion mounting

SENSORS #1-6 (must be in alphabetical order)

N	None
A	Boiler sensor with ATC, 250 psi, K=1.0, 20ft.cable
B	Boiler sensor no ATC, 250 psi, K=1.0, 20ft.cable
C	Condensate sensor with ATC, 200 psi, K=0.1, 10ft.cable
D	Boiler sensor with ATC, 250 psi, K=10, 20ft.cable

DIMENSIONS

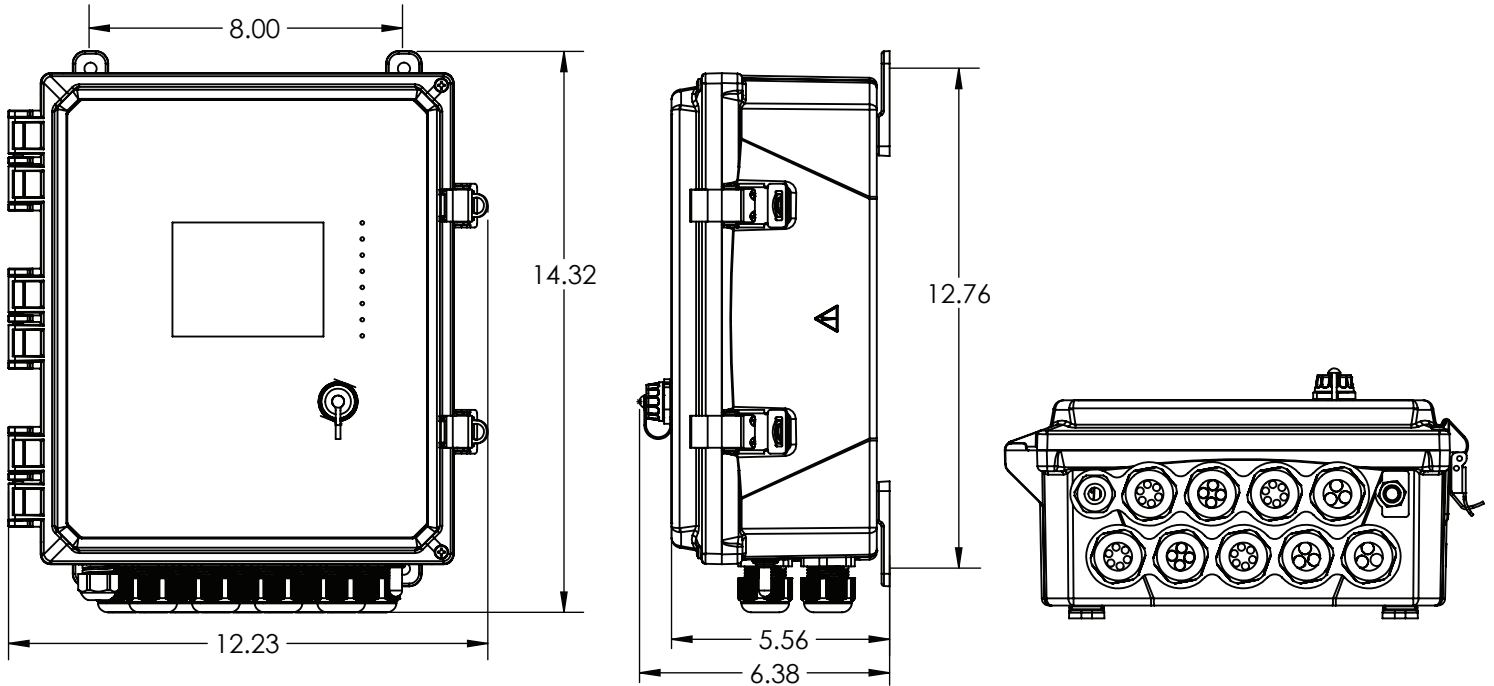

ABOUT US

Walchem integrates its advanced sensing, instrumentation, fluid pumping and communications technologies to deliver reliable and innovative solutions to the global water treatment market. Our in-house engineering is driven by quality, technology and innovation. For more information on the entire Walchem product line, visit: www.walchem.com.

W A L C H E M

IWAKI America Inc.

P/N 180687.H January 2022

Walchem, Iwaki America Inc.

Five Boynton Road Hopping Brook Park | Holliston, MA 01746 USA | Phone 508-429-1110 | walchem.com