

WCT Intuition-6™ Series Cooling Tower Controllers

Part 1. General

1.1 Scope

- A.** This section describes the requirements for a multiple input/output cooling tower controller.
- B.** Under this item, the contractor shall furnish and install the cooling tower control equipment and accessories as indicated on the plans and as herein specified.

1.2 Submittals

- A.** The following information shall be included in the submittal for this section:
 - 1. Data sheets and catalog literature for the cooling tower controller and sensors.
 - 2. Interconnection and dimensional drawings.
 - 3. List of spare parts

Part 2. Products

2.1 Cooling tower controller

- A.** The cooling tower control system shall be a capable of measuring system conductivity and temperature. The conductivity sensors shall be either a contacting style or an electrodeless style. An optional second sensor shall be a choice of pH, ORP, PTSA, free chlorine, total chlorine, chlorine dioxide, ozone, Peracetic acid, or hydrogen peroxide. Six digital inputs are available for sensors that shall include a flow switch, contacting water meter, paddlewheel flowmeter or other dry contact devices. Outputs shall include six mechanical relays, and two optional 4-20 mA outputs. Digital communications shall be via Ethernet. The controller shall be accessible via the Internet for configuring, data logging, and control of relay outputs. The USB port shall provide the ability to upgrade the software in the controller to the latest version, save all the set points from a controller onto a USB flash disk and import settings into another Intuition-6 controller, and download datalog files to a USB flash disk. On screen graphing of two analog signals and one digital signal/relay state shall be available on the touchscreen display.

B. Control Module:

1. Enclosure: Polycarbonate Resin, NEMA 4X, lockable hinged door.

2. Power: 100-240 VAC \pm 10%, 50 or 60 Hz

3. Inputs:

Sensor Input Signals (0, 1 or 2 depending on model code)

Contacting Conductivity 0.01, 0.1, 1.0, or 10.0 cell constant OR
Electrodeless Conductivity OR
Disinfection OR

Amplified pH or ORP Requires a preamplified signal. Walchem WEL or WDS series recommended.
 \pm 5VDC power available for external preamps.

Each sensor input card contains a temperature input

Temperature 100 or 1000 ohm RTD, 10K or 100K Thermistor

Analog (4-20 mA) Sensor Input (0, 2 or 4 depending on model code)

2-wire loop powered or self-powered transmitters supported

3 or 4 –wire transmitters supported

Each sensor input board has two channels

Channel 1, 130 ohm input resistance

Channel 2, 280 ohm input resistance

Available Power Two independent isolated 24 VDC \pm 15% supplies per board
1.5 W maximum for each channel

2W (83 mA at 24 VDC) total power consumption for all channels (four total channels if two boards are installed; 2W is equivalent to 2 Little Dipper sensors)

Digital Input Signals (6):

State-Type Digital Inputs

Electrical: Optically isolated and providing an electrically isolated 9V power with a nominal 2.3mA current when the digital input switch is closed

Typical response time: < 2 seconds

Devices supported: Any isolated dry contact (i.e. relay, reed switch)

Types: Interlock

Low Speed Counter-Type
Digital Inputs

Electrical: Optically isolated and providing an electrically isolated 9V power with a nominal 2.3mA current when the digital input switch is closed 0-10 Hz, 50 msec minimum width

Devices supported: Any device with isolated open drain, open collector, transistor or reed switch

Types: Contacting Flowmeter

High Speed Counter-Type
Digital Inputs

Electrical: Optically isolated and providing an electrically isolated 9V power with a nominal 2.3mA current when the digital input switch is closed, 0-250 Hz, 1.25 msec minimum width

Devices supported: Any device with isolated open drain, open collector, transistor or reed switch

Types: Paddlewheel Flowmeter

4. Outputs:

Powered mechanical relays (0 or 6 depending on model code):

Pre-powered on circuit board switching line voltage

6 A (resistive), 1/8 HP (93 W)

All six relays are fused together as one group, total current for this group must not exceed 6A

Dry contact mechanical relays (0, 2 or 4 depending on model code):

6 A (resistive), 1/8 HP (93 W)

Dry contact relays are not fuse protected

Pulse Outputs (0, 2 or 4 depending on model code):

	Opto-isolated, Solid State Relay
	200mA, 40 VDC Max.
	VLOWMAX = 0.05V @ 18 mA
4 - 20 mA (0 or 2)	Internally powered
	Fully isolated
	600 Ohm max resistive load
	Resolution 0.0015% of span
	Accuracy \pm 0.5% of reading
Ethernet	10/100 802.3-2005
	Auto MDIX support
	Auto Negotiation

5. Software features:

Six relay outputs may be set to a variety of control modes:

On/Off set point control

Time Proportional control

Pulse Proportional Control (requires pulse output relay option)

Flow Proportional

PID control

Dual set point

Bleed or Feed based on a Water Contactor or Paddlewheel flow meter input

Feed and Bleed

Feed and Bleed with Lockout

Feed as a percent of Bleed

Feed as a percent of elapsed time

Flowmeter Ratio

Spike to alternate set point on timed basis

Probe Wash Timer

Daily, Weekly, 2-week or 4-week Biocide timers with pre-bleed and post-add lockout of bleed

Intermittent sampling for boilers with proportional blowdown, controlling on a trapped sample

Always on unless interlocked

Diagnostic Alarm

Six Virtual Inputs are configurable in the software, to either allow for calculations based on two real inputs, or to allow to compare values from two sensors to provide redundancy.

Six Virtual (Control) Outputs are configurable in the software, using most of the possible relay or analog output control algorithms, that may be used to interlock or activate actual control outputs.

Manual activation of the relays shall be easily accomplished via the keypad, or a PC.

A maximum output on-time shall be available on the control relays to prevent runaway control.

Any relay may be reconfigured to any one of a number of control algorithms, responding to the signal from any input desired.

The optional analog inputs shall be configurable for fluorometers, level sensors, corrosion monitors, flowmeters or any other type of transmitter, providing appropriate units of measure and scaling.

The digital inputs shall be configurable for level switches, flowmeters, flow switches, or generic interlock operation.

The optional analog outputs shall be configurable for retransmitting a sensor signal or for linear proportional, flow proportional, or PID control.

The controller set points may be entered by downloading them from one controller, and uploading them into another controller.

Access to the controller shall be possible using Ethernet, locally or via the Internet, or via the local touchscreen display, simultaneously if desired.

The optional Ethernet feature provides remote access to the controller's programming via a PC connected directly, via a local area network, or via Walchem Fluent® account management server. It also allows emailing of datalog files (in CSV format, compatible with spreadsheets like Excel) and alarms, to up to eight email addresses. The Modbus TCP and BACnet remote communications options allow communication with PC-based applications, HMI/SCADA programs, Building Energy Management systems, Distributed Control Systems (DCS), as well as stand-alone HMI devices.

No proprietary software shall be required on the user's computer to communicate with the controller, or to view or change set points.

C. Sensors:

Contacting Conductivity

1. Operating principle: The conductivity sensor shall be driven with a low voltage AC signal, and the return signal voltage will vary with the conductivity of the intervening solution. The temperature sensor within this sensor compensates for the effect of temperature on the conductivity signal.
2. Materials of construction: Glass-Filled Polypropylene, Graphite or 316SS, FKM
3. Process connections: 3/4" NPTF
4. Temperature range: 32-158 F, 0-70 C
5. Pressure range: 0-150 psi
6. Other materials and higher pressure sensors shall be made available.

Electrodeless Conductivity

1. Operating principle: The conductivity sensor shall be driven with a low voltage AC signal, which induces a current in the surrounding liquid which varies in intensity with the conductivity of the liquid, which is picked up by the sensor and transmitted to the controller. The temperature sensor within this sensor compensates for the effect of temperature on the conductivity signal.
2. Materials of construction: CPVC, FKM
3. Process connections: 3/4" NPTF
4. Temperature range: 32-158 F, 0-70 C
7. Pressure range: 0-150 psi

pH

1. Operating principle: The pH sensor shall consist of a replaceable cartridge containing a pH sensitive glass and silver/silver chloride reference. Voltage signals from these shall be measured against the solution ground, and the differential voltage measurement sent to the control module. The temperature signal from the conductivity sensor shall be used to compensate the pH reading as well.
2. Materials of construction: Glass-Filled Polypropylene, CPVC, HDPE, FKM, Glass
3. Process connections: 3/4" NPTF
4. Temperature range: 50-158 F, 10-70 C
5. Pressure range: 0-100 psi
6. Other materials and higher pressure sensors shall be made available.

ORP

1. Operating principle: The ORP sensor shall consist of a replaceable cartridge containing a platinum electrode and silver/silver chloride reference. Voltage signals from these shall be measured against the solution ground, and the differential voltage measurement sent to the control module.
2. Materials of construction: Glass-Filled Polypropylene, CPVC, HDPE, FKM, Glass, and Platinum.
3. Process connections: 3/4" NPTF
4. Temperature range: 32-158 F, 0-70 C
5. Pressure range: 0-100 psi
6. Other materials and higher pressure sensors shall be made available.

DISINFECTION

1. Operating principle: The oxidizer molecules diffuse through the membrane and in the acidic environment of the electrolyte fill solution, a redox reaction occurs at the electrodes in the sensor. The current generated by this reaction is converted to a robust voltage signal that is linear with the concentration of the oxidizer.
2. Materials of construction: Glass-Filled Polypropylene, PVC, Silicone rubber, polycarbonate, 316SS, PEEK.
3. Process connections: 3/4" NPTF
4. Temperature range: 41-113 F, 5-45 C (typical)
5. Pressure range: 0-14.7 psi (0-1 atmosphere)

D. Controller and Sensor Performance

0.01 Cell Contacting Conductivity

Range	0-300 $\mu\text{S/cm}$
Resolution	0.01 $\mu\text{S/cm}$, 0.0001 mS/cm, 0.001 mS/m, 0.0001 S/m, 0.01 ppm
Accuracy	$\pm 1\%$ of reading or 0.01 $\mu\text{S/cm}$, whichever is greater

0.1 Cell Contacting Conductivity

Range	0-3,000 $\mu\text{S/cm}$
Resolution	0.1 $\mu\text{S/cm}$, 0.0001 mS/cm, 0.01 mS/m, 0.0001 S/m, 0.1 ppm
Accuracy	$\pm 1\%$ of reading or 0.1 $\mu\text{S/cm}$, whichever is greater

1.0 Cell Contacting Conductivity

Range	0-30,000 $\mu\text{S/cm}$
Resolution	1 $\mu\text{S/cm}$, 0.001 mS/cm, 0.1 mS/m, 0.0001 S/m, 1 ppm
Accuracy	$\pm 1\%$ of reading or 1 $\mu\text{S/cm}$, whichever is greater

10.0 Cell Contacting Conductivity

Range	0-300,000 $\mu\text{S/cm}$
Resolution	10 $\mu\text{S/cm}$, 0.01 mS/cm, 1 mS/m, 0.001 S/m, 10 ppm
Accuracy	$\pm 1\%$ of reading or 10 $\mu\text{S/cm}$, whichever is greater

pH

Range	-2 to 16 pH units
Resolution	0.01 pH units
Accuracy	$\pm 0.01\%$ of reading

ORP

Range	-1500 to 1500 mV
Resolution	0.1 mV
Accuracy	± 1 mV

Disinfection Sensors

Range (mV)	-2000 to 1500 mV	Range (ppm)	0-2 ppm to 0-20,000 ppm
Resolution (mV)	0.1 mV	Resolution (ppm)	Varies with range and slope
Accuracy (mV)	± 1 mV	Accuracy (ppm)	Varies with range and slope

Temperature

Range	23 to 500°F (-5 to 260°C)
Resolution	0.1°F (0.1°C)
Accuracy	$\pm 1\%$ of reading

Analog (4-20 mA)

Range	0 to 22 mA
Resolution	0.01 mA
Accuracy	$\pm 0.5\%$ of reading

Electrodeless Conductivity

Ranges	Resolution	Accuracy
500-12,000 $\mu\text{S/cm}$	1 $\mu\text{S/cm}$, 0.01 mS/cm, 0.1 mS/m, 0.001 S/m, 1 ppm	$\pm 1\%$ of reading
3,000-40,000 $\mu\text{S/cm}$	1 $\mu\text{S/cm}$, 0.01 mS/cm, 0.1 mS/m, 0.001 S/m, 1 ppm	$\pm 1\%$ of reading
10,000-150,000 $\mu\text{S/cm}$	10 $\mu\text{S/cm}$, 0.1 mS/cm, 1 mS/m, 0.01 S/m, 10 ppm	$\pm 1\%$ of reading
50,000-500,000 $\mu\text{S/cm}$	10 $\mu\text{S/cm}$, 0.1 mS/cm, 1 mS/m, 0.01 S/m, 10 ppm	$\pm 1\%$ of reading
200,000-2,000,000 $\mu\text{S/cm}$	100 $\mu\text{S/cm}$, 0.1 mS/cm, 1 mS/m, 0.1 S/m, 100 ppm	$\pm 1\%$ of reading

E. Indication

1. Graphic User Interface

A 5" TFT color display, 800 x 480 pixels with capacitive touchscreen shall indicate the process values, the status of outputs and alarms, and provide for all settings and calibrations.

Two LED lamps shall indicate the alarm status and software operation status.

F. Equipment

The cooling tower controller shall be a Walchem WCT Intuition-6 series.

Part 3. Operator Functions

3.1 Calibration

- A.** The sensor calibration shall be a one point process calibration, a two point buffer calibration, or a one point buffer calibration.
- B.** All set points shall be set through the touchscreen, or via a PC connected either locally or remotely via Ethernet.
- C.** Two levels of access codes shall be available to protect all set points and calibrations, while allowing the user to view any set point.

3.2 Control Module Function Details

- A.** Each control output shall be able to be set to any of the available control modes listed above.
- B.** The inhibitor chemical feed output shall be on/off control with four choices of feed modes.
- C.** All control relays shall have limit timers to prevent runaway control.
- D.** The biocide programs shall provide a conductivity-based or a time-based prebleed prior to the biocide addition, and a time-based lockout of the bleed after the biocide addition.
- E.** The controller shall be able to interlock any relay output based on a digital input, or based on another specific relay being active.

Part 4. Execution

Installation

- A.** The sensors shall be installed in a location where they will always remain immersed in the sample.
- B.** The sensors shall be installed in a location where there is good solution movement and where they will respond rapidly to changes
- C.** The sensor cables shall be routed such that they are separated from any AC voltage by at least 6 inches.
- D.** If the sensor cable needs to be extended beyond the standard length, then 24 AWG, 3 twisted pair, shielded cable shall be utilized.

- E. If the optional 4 – 20 mA output or water meter contactor are installed, then 22-26 AWG, twisted pair, shielded cable shall be utilized.
- F. The sample line shall be tapped from the discharge side of the cooling tower recirculation pump and returned to either the cooling tower sump or the suction side of the recirculation pump.

Part 5. Warranty

5.1 Terms

- A. The manufacturer of the above specified equipment shall guarantee equipment of its manufacture, and bearing its identification to be free from defects in workmanship and material for a period of 24 months for electronics and 12 months for mechanical parts from date of delivery from the factory or authorized distributor under normal use and service and otherwise when such equipment is used in accordance with instructions furnished by the manufacturer and for the purposes disclosed in writing at the time of purchase, if any.
- B. In the event a component fails to perform as specified and having been returned to the manufacturer transportation charges prepaid, and is proven defective in service during the warranty period, the manufacturer shall repair or replace the defective part. Replaceable elastomeric parts and glass components are expendable and are not covered by any warranty.

Part 6. Options

6.1 Related Equipment

- A. Solenoid valve for bleed control
- B. Water meter for makeup and/or bleed flow
- C. Level switch or level transmitter for chemical level monitoring
- D. Metering pumps for chemical control

Part 7. Spare Parts

7.1 Recommended Spare Parts

- A. 102834 Fuse, F1, 6 amp 250 V, 5 x 20 mm

Part 8 Dimensions

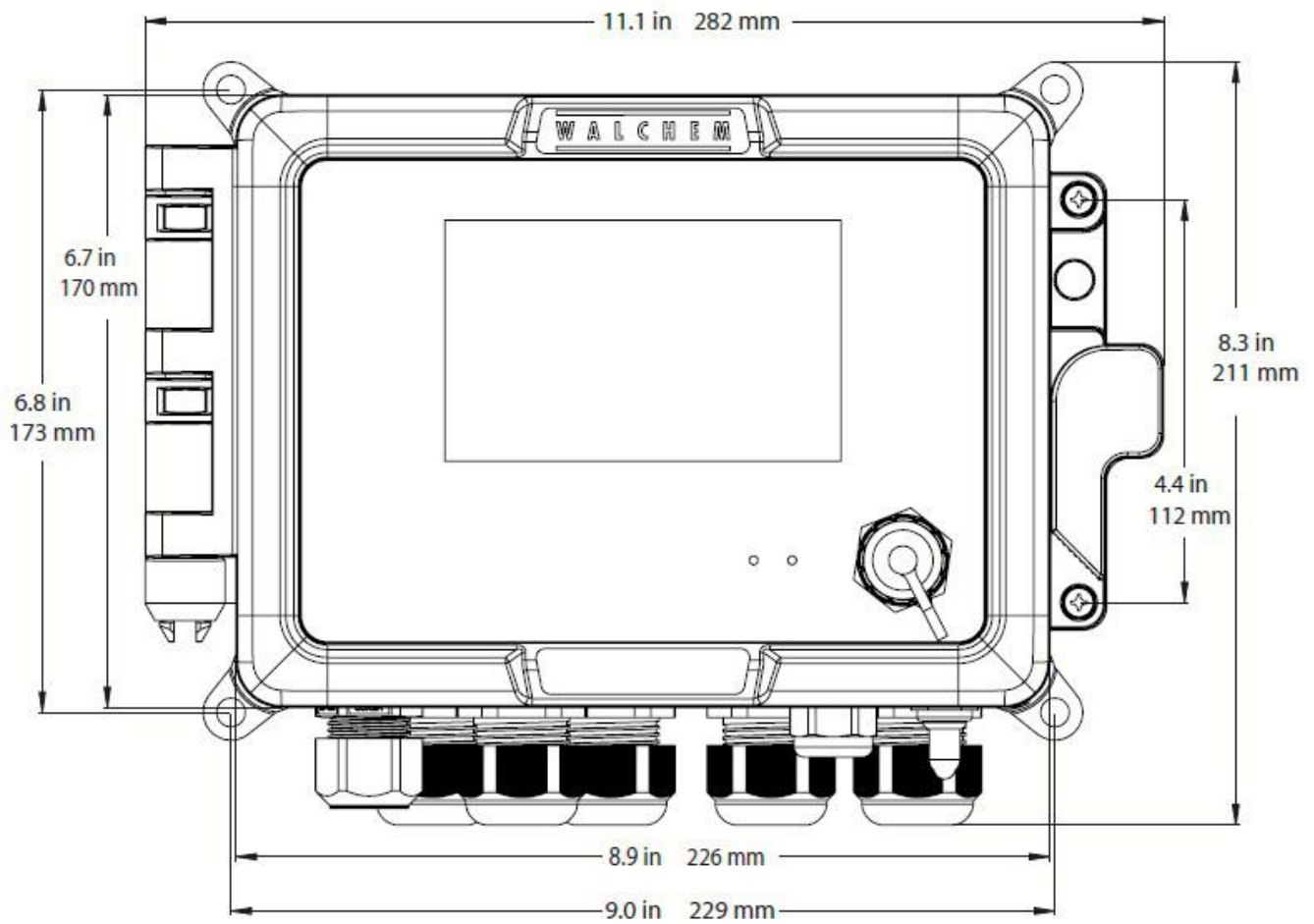
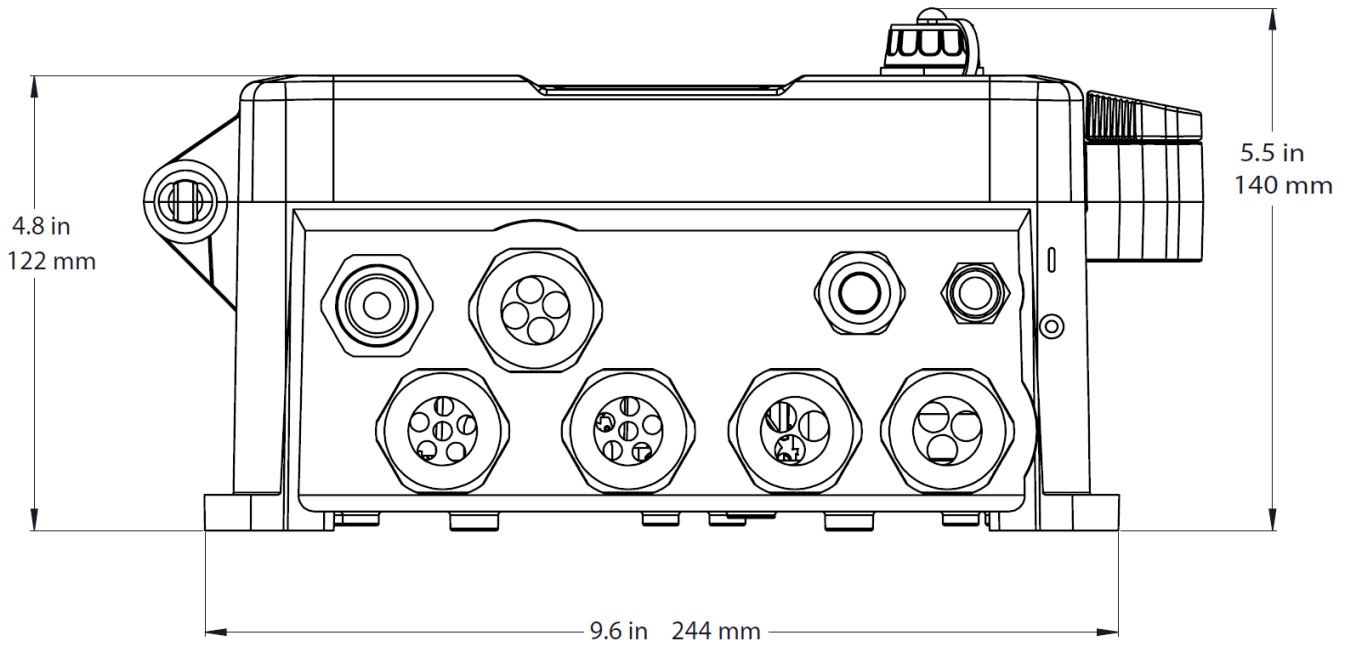

Part 9 Wiring

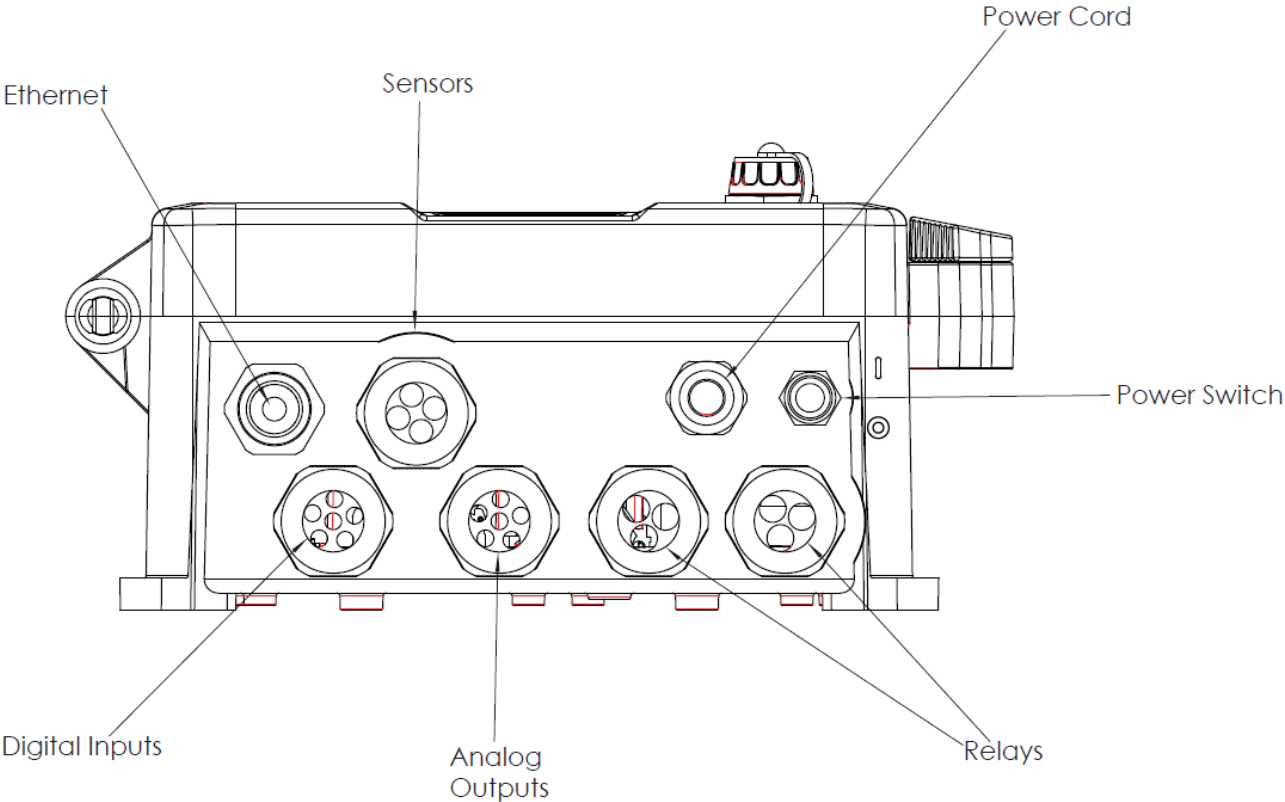

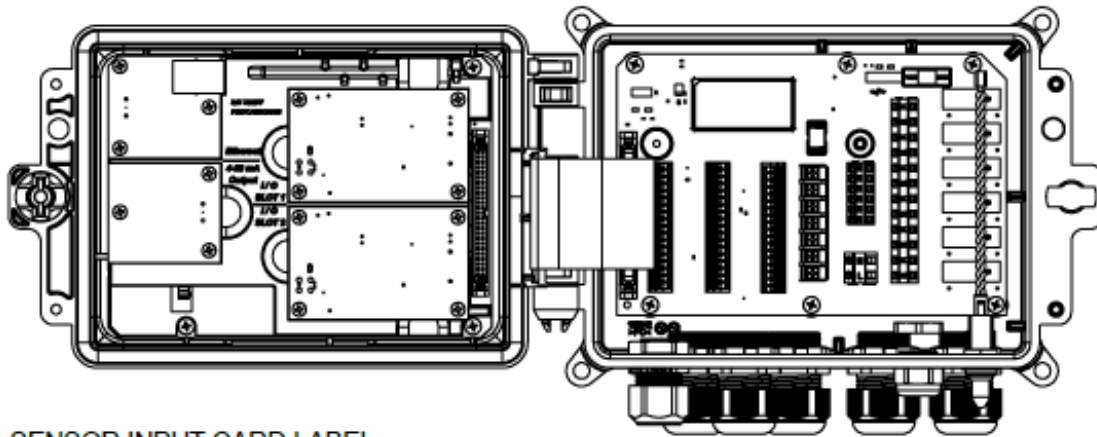

SENSOR INPUT CARD LABEL

	ECOND	CCOND	pH/ORP DIS
1	TEMP-	TEMP-	TEMP-
2	TEMP+	TEMP+	TEMP+
3	R-SHLD		IN-
4		RCV	IN+
5	RCV-		
6	RCV+		
7	X-SHLD	SHIELD	SHIELD
8			+5V
9			-5V
10	XMT+	XMT	
11	XMT-		
12			

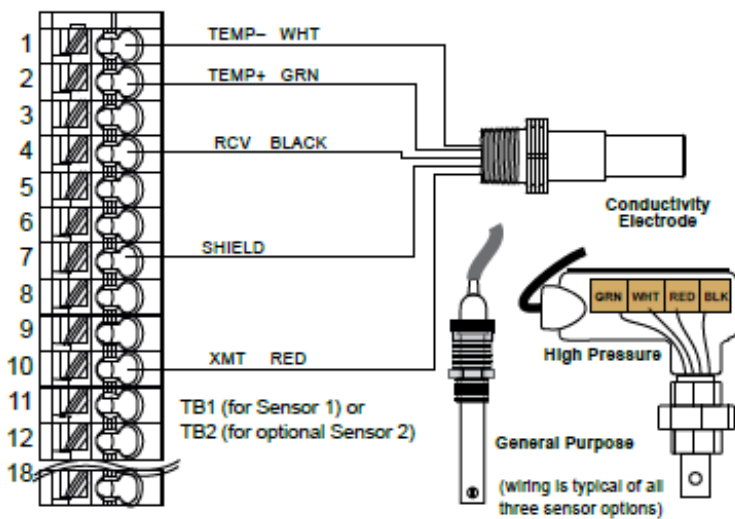

	CCOND	pH/ORP DIS	2 Wire Loop	2 Wire Pwrd	3 Wire	4 Wire
1	TEMP-	TEMP-				
2	TEMP+	TEMP+				
3	SHIELD	IN-				
4	RCV	IN+				
5		-5V				
6	XMT					
7		+5V				
8					COM(-)	24V(-)
9			+24V		+24V	+24V
10				XMTR-		XMTR-
11				XMTR-	XMTR+	XMTR+
12			SHIELD or use DI SHIELD (TB3 7-12)			

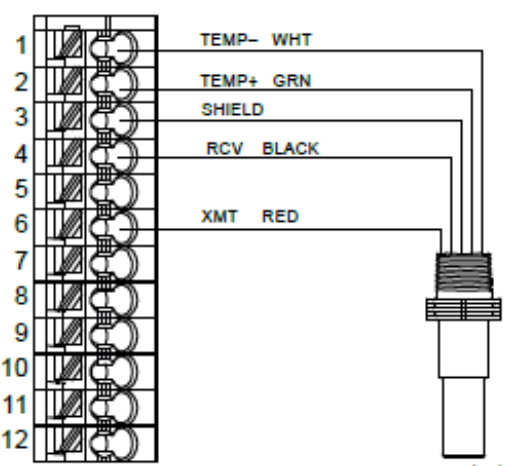

COMBINATION SENSOR/ANALOG CARD LABEL

TB1 (for Sensor 1) or TB2 (for optional Sensor 2)

Figure 7 Contacting Conductivity Sensor Input Wiring

	ECOND	CCOND	pH/ORP DIS
1	TEMP-	TEMP-	TEMP-
2	TEMP+	TEMP+	TEMP+
3	R-SHLD		IN-
4		RCV	IN+
5	RCV-		
6	RCV+		
7	X-SHLD	SHIELD	SHIELD
8			+5V
9			-5V
10	XMT+	XMT	
11	XMT-		
12	⏏		

SENSOR LABEL

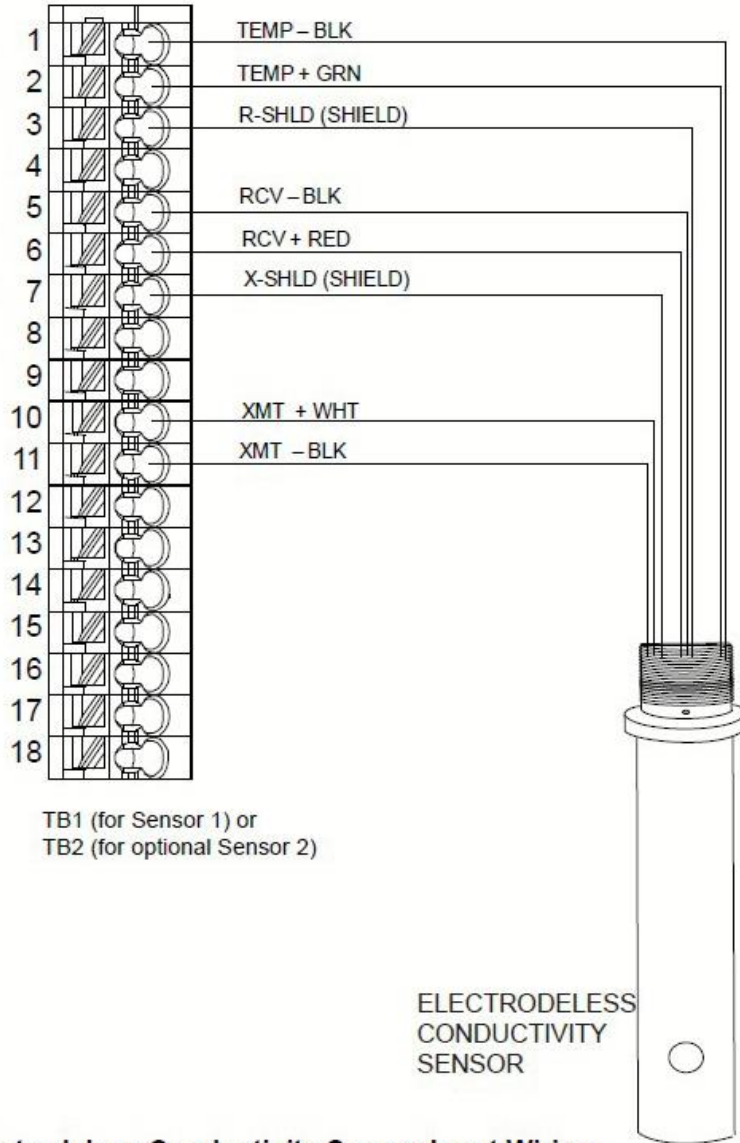
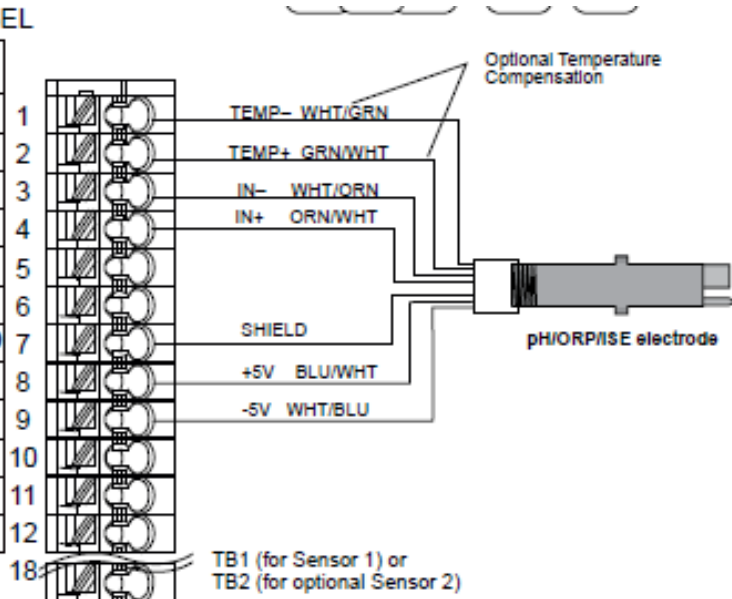

Figure 8 Electrodeless Conductivity Sensor Input Wiring

SENSOR INPUT CARD LABEL

	ECOND	CCOND	pH/ORP DIS
1	TEMP-	TEMP-	TEMP-
2	TEMP+	TEMP+	TEMP+
3	R-SHLD		IN-
4		RCV	IN+
5	RCV-		
6	RCV+		
7	X-SHLD	SHIELD	SHIELD
8			+5V
9			-5V
10	XMT+	XMT	
11	XMT-		
12	⏏		



	CCOND	pH/ORP DIS	2 Wire Loop	2 Wire Pwrd	3 Wire	4 Wire
1	TEMP-	TEMP-				
2	TEMP+	TEMP+				
3	SHIELD	IN-				
4	RCV	IN+				
5		-5V				
6	XMT					
7		+5V				
8					COM(-)	24V(-)
9			+24V		+24V	+24V
10				XMTR-		XMTR-
11				XMTR-	XMTR+	XMTR+
12						

COMBINATION SENSOR/ANALOG CARD LABEL

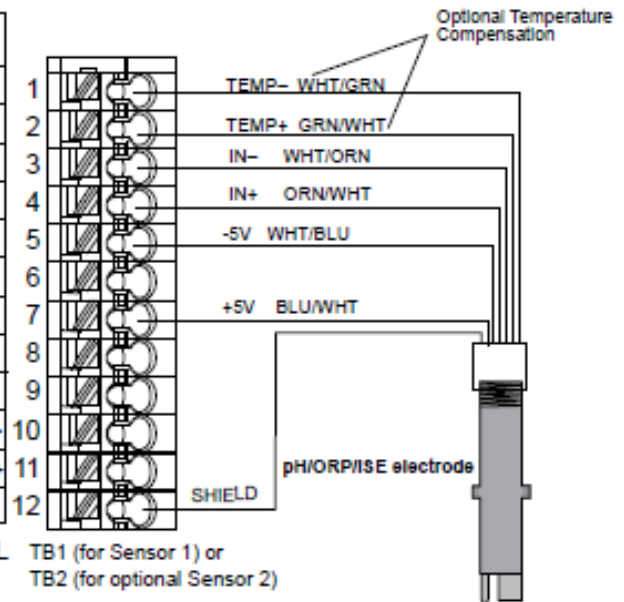
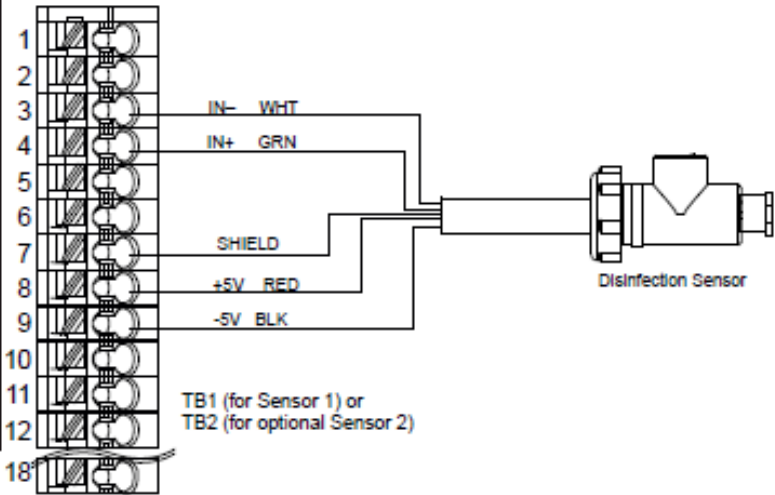

Figure 9 pH/ORP/ISE Sensor Input Wiring

SENSOR INPUT CARD LABEL

	ECOND	CCOND	pH/ORP DIS
1	TEMP-	TEMP-	TEMP-
2	TEMP+	TEMP+	TEMP+
3	R-SHLD		IN-
4		RCV	IN+
5	RCV-		
6	RCV+		
7	X-SHLD	SHIELD	SHIELD
8			+5V
9			-5V
10	XMT+	XMT	
11	XMT-		
12			



	CCOND	pH/ORP DIS	2 Wire Loop	2 Wire Pwr	3 Wire	4 Wire
1	TEMP-	TEMP-				
2	TEMP+	TEMP+				
3	SHIELD	IN-				
4	RCV	IN+				
5		-5V				
6	XMT	+5V				
8					COM(-)	24V(-)
9			+24V		+24V	+24V
10					XMTR-	XMTR-
11					XMTR+	XMTR+
12			SHIELD or use DI SHIELD (TB3 7-12)			

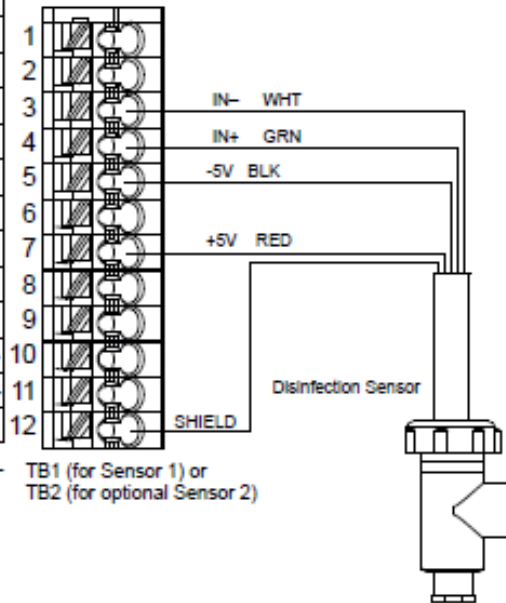

COMBINATION SENSOR/ANALOG CARD LABEL

TB1 (for Sensor 1) or
TB2 (for optional Sensor 2)

Figure 10 Disinfection Sensor Input Wiring

TB Pin#	Type of Transmitter				AI#
	2 Wire Loop	2 Wire Powered	3 Wire	4 Wire	
1	+24V		+24V	+24V	1
2	●		●	24V(-)	
3	●		●	XMTR-	
4	XMTR-	XMTR+	XMTR+	XMTR+	
5			COM(-)		
6	SHIELD	SHIELD	SHIELD	SHIELD	
7	+24V		+24V	+24V	2
8	●		●	24V(-)	
9	●		●	XMTR-	
10	XMTR-	XMTR+	XMTR+	XMTR+	
11			COM(-)		
12	SHIELD	SHIELD	SHIELD	SHIELD	

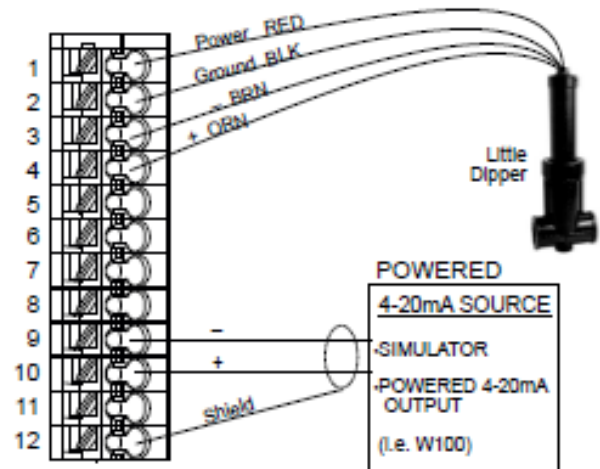

TB1 (for Sensor 1) or
TB2 (for optional Sensor 2)

TB Pin#	Type of Transmitter				AI#
	2 Wire Loop	2 Wire Powered	3 Wire	4 Wire	
1	+24V		+24V	+24V	1
2	●		●	24V(-)	
3	●		●	XMTR-	
4	XMTR-	XMTR+	XMTR+	XMTR+	
5			COM(-)		
6	SHIELD	SHIELD	SHIELD	SHIELD	
7	+24V		+24V	+24V	2
8	●		●	24V(-)	
9	●		●	XMTR-	
10	XMTR-	XMTR+	XMTR+	XMTR+	
11			COM(-)		
12	SHIELD	SHIELD	SHIELD	SHIELD	

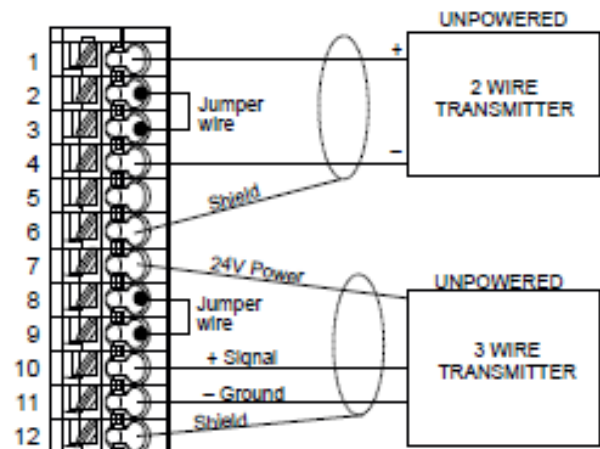

TB1 (for Sensor 1) or
TB2 (for optional Sensor 2)

Figure 11 Dual 4-20mA Sensor Input Wiring

SENSOR LABEL

	CCOND	pH/ORP DIS	2 Wire Loop	2 Wire Pwrd	3 Wire	4 Wire
1	TEMP-	TEMP-				

TB1 (for Sensor 1) or
TB2 (for optional Sensor 2)



8					COM(-)	24V(-)
9			+24V		+24V	+24V
10				XMTR-		XMTR-
11				XMTR-	XMTR+	XMTR+
12			SHIELD or use DI SHIELD (TB3 7-12)			

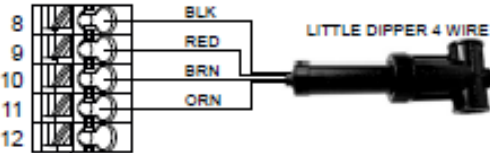

	CCOND	pH/ORP DIS	2 Wire Loop	2 Wire Pwrd	3 Wire	4 Wire
1	TEMP-	TEMP-				



8					COM(-)	24V(-)
9			+24V		+24V	+24V
10				XMTR-		XMTR-
11				XMTR-	XMTR+	XMTR+
12			SHIELD or use DI SHIELD (TB3 7-12)			

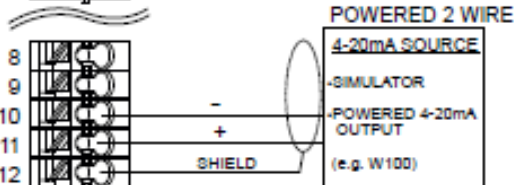

	CCOND	pH/ORP DIS	2 Wire Loop	2 Wire Pwrd	3 Wire	4 Wire
1	TEMP-	TEMP-				



8					COM(-)	24V(-)
9			+24V		+24V	+24V
10				XMTR-		XMTR-
11				XMTR-	XMTR+	XMTR+
12			SHIELD or use DI SHIELD (TB3 7-12)			

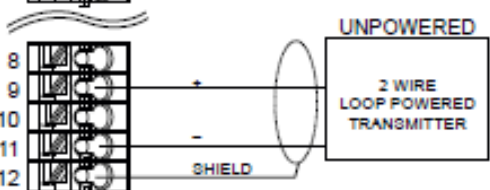

	CCOND	pH/ORP DIS	2 Wire Loop	2 Wire Pwrd	3 Wire	4 Wire
1	TEMP-	TEMP-				



8					COM(-)	24V(-)
9			+24V		+24V	+24V
10				XMTR-		XMTR-
11				XMTR-	XMTR+	XMTR+
12			SHIELD or use DI SHIELD (TB3 7-12)			

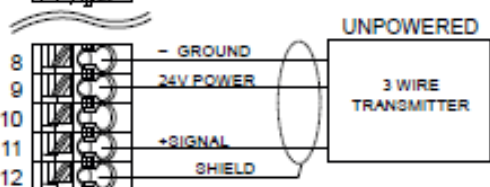

NOTE: To program the combination card analog input, you must go to Inputs menu, then enter the analog input (S13 or S23), scroll down to Transmitter, and select the type of transmitter from the list.

Figure 12 Combination Card 4-20mA Dual Sensor Input Wiring

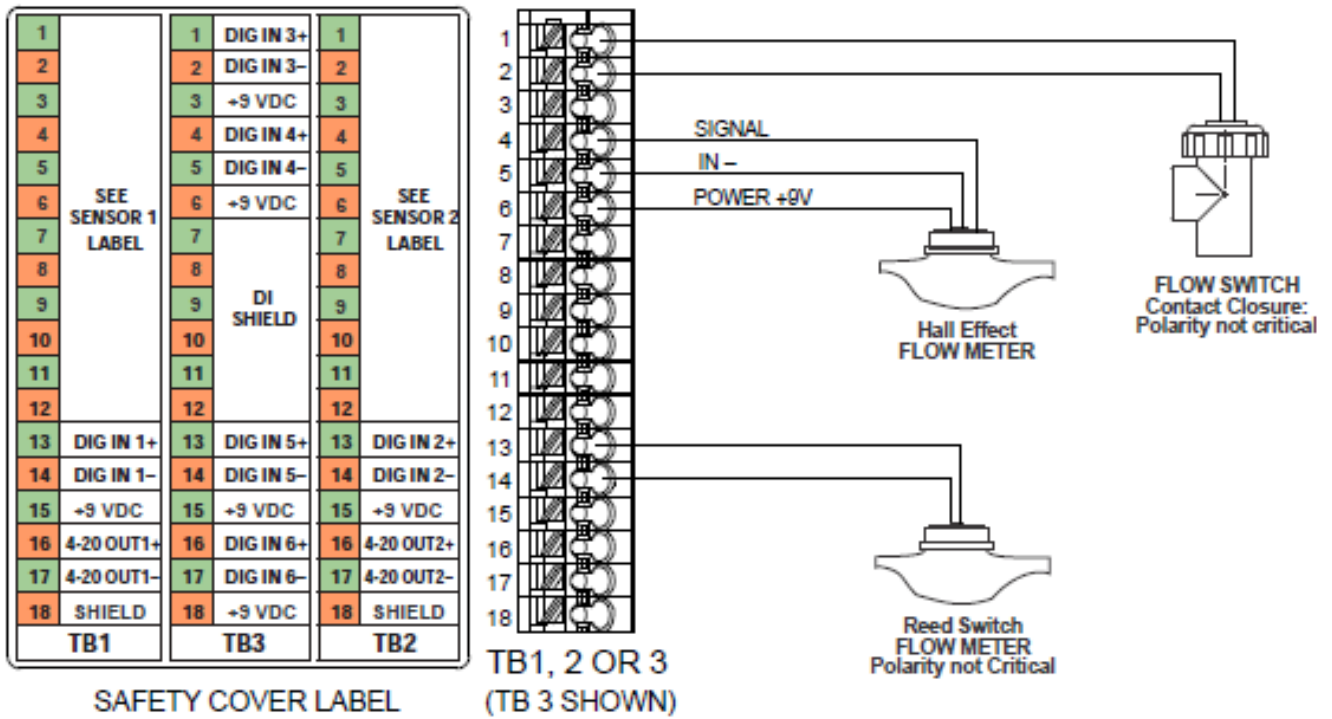

Figure 13 Digital Input Wiring

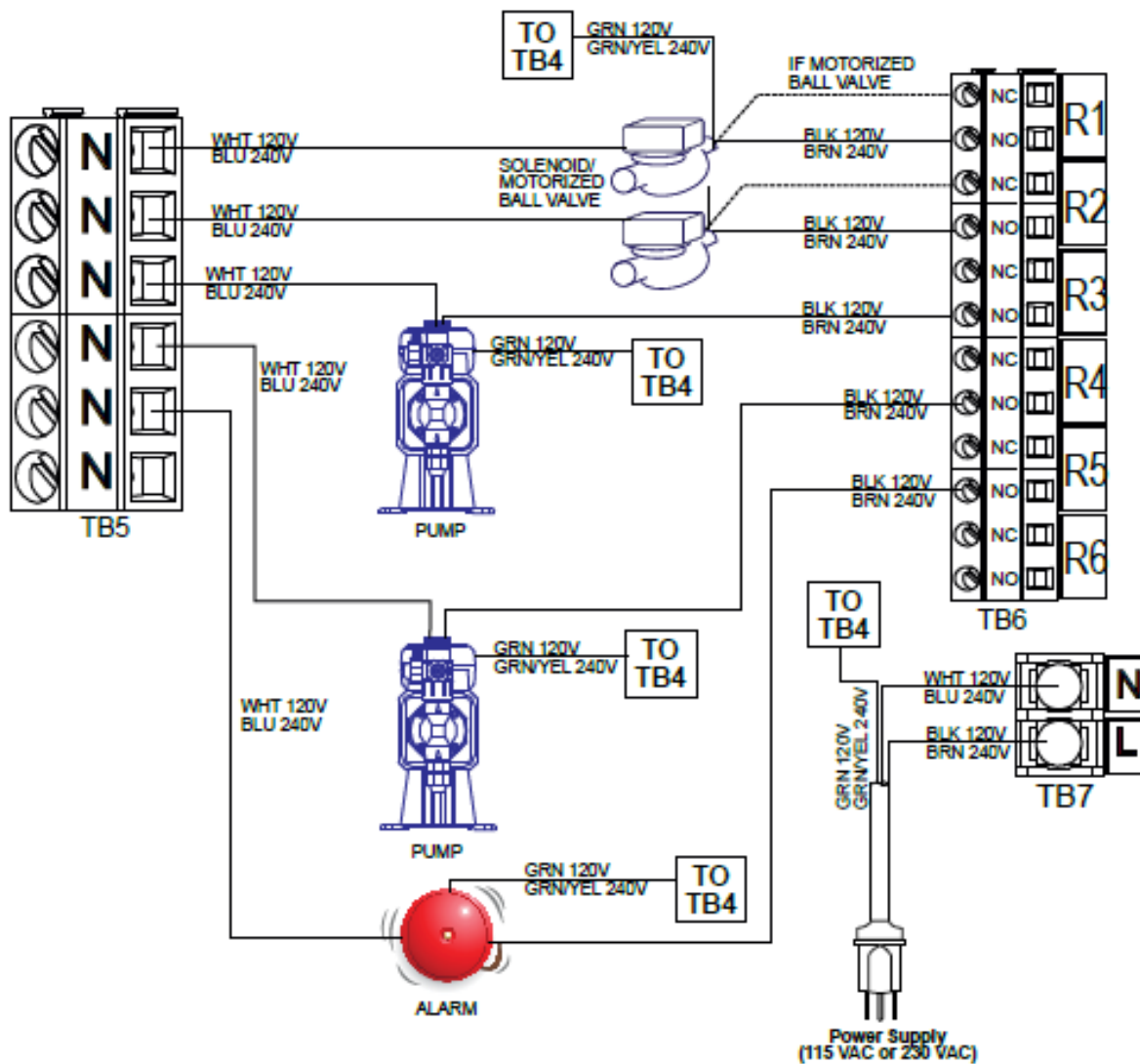

Figure 14 W600 AC Power & Relay Output Wiring

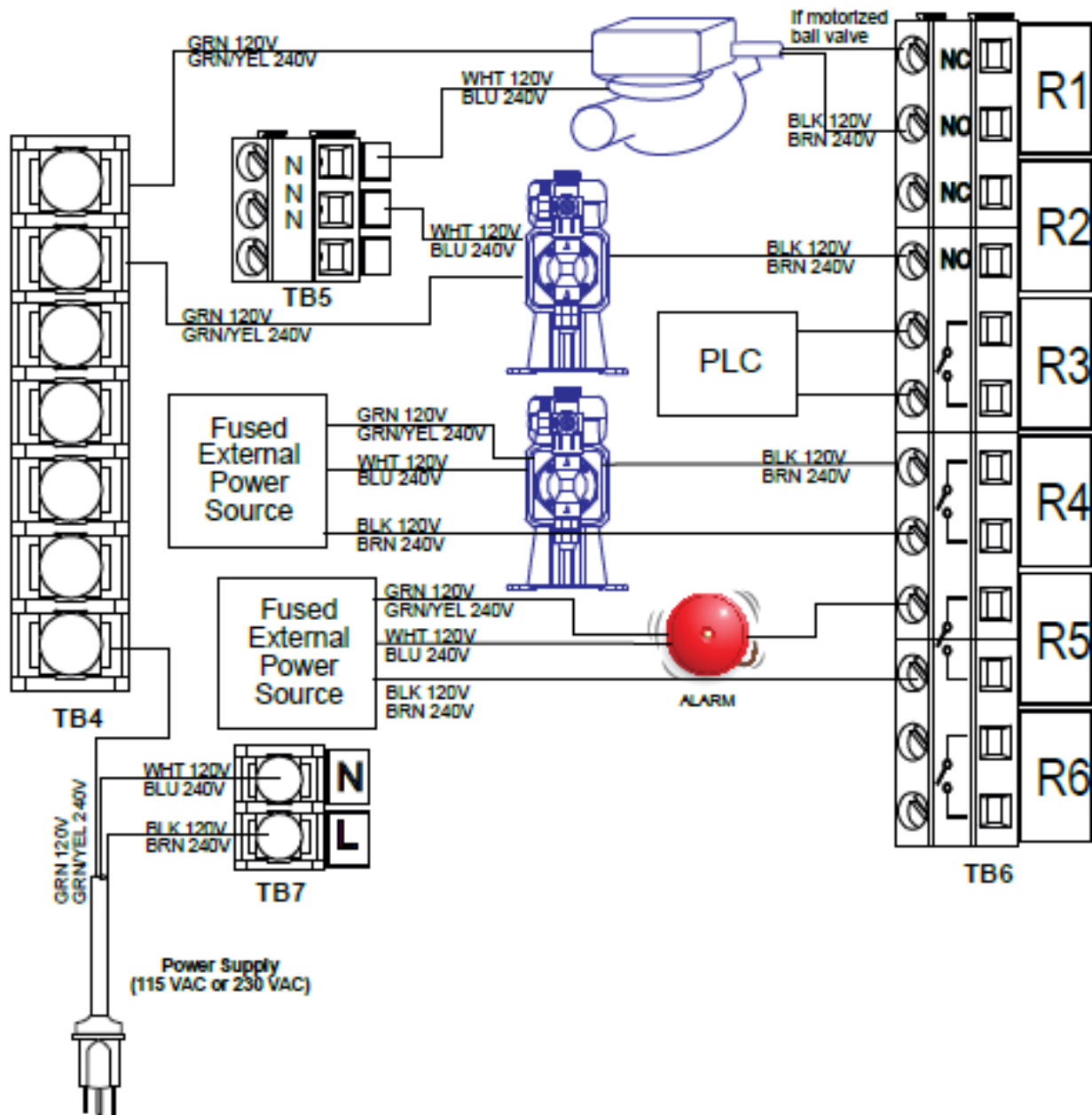

Figure 15 W610 AC Power & Relay Output Wiring

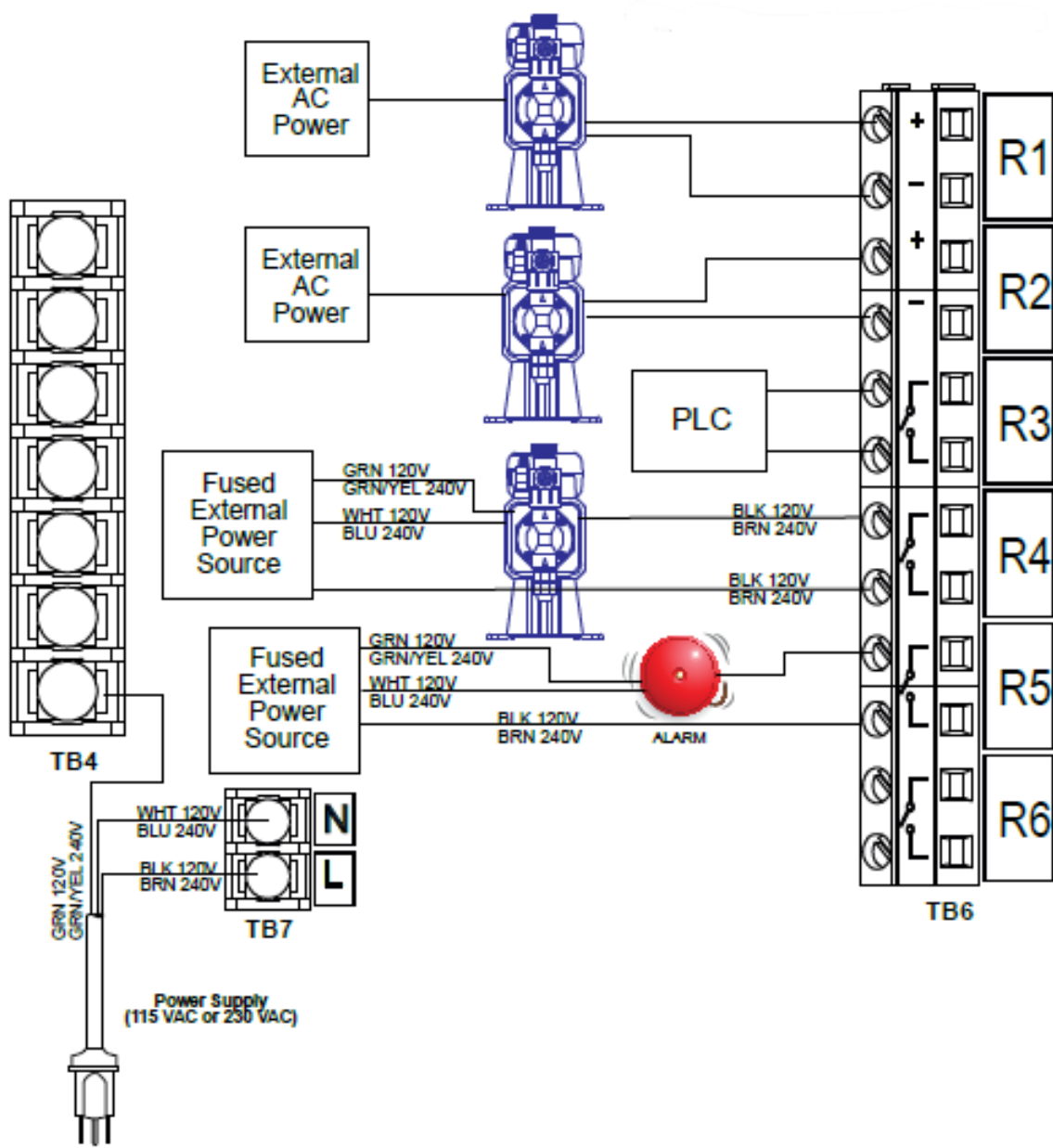

Figure 16 W620 AC Power & Relay Output Wiring

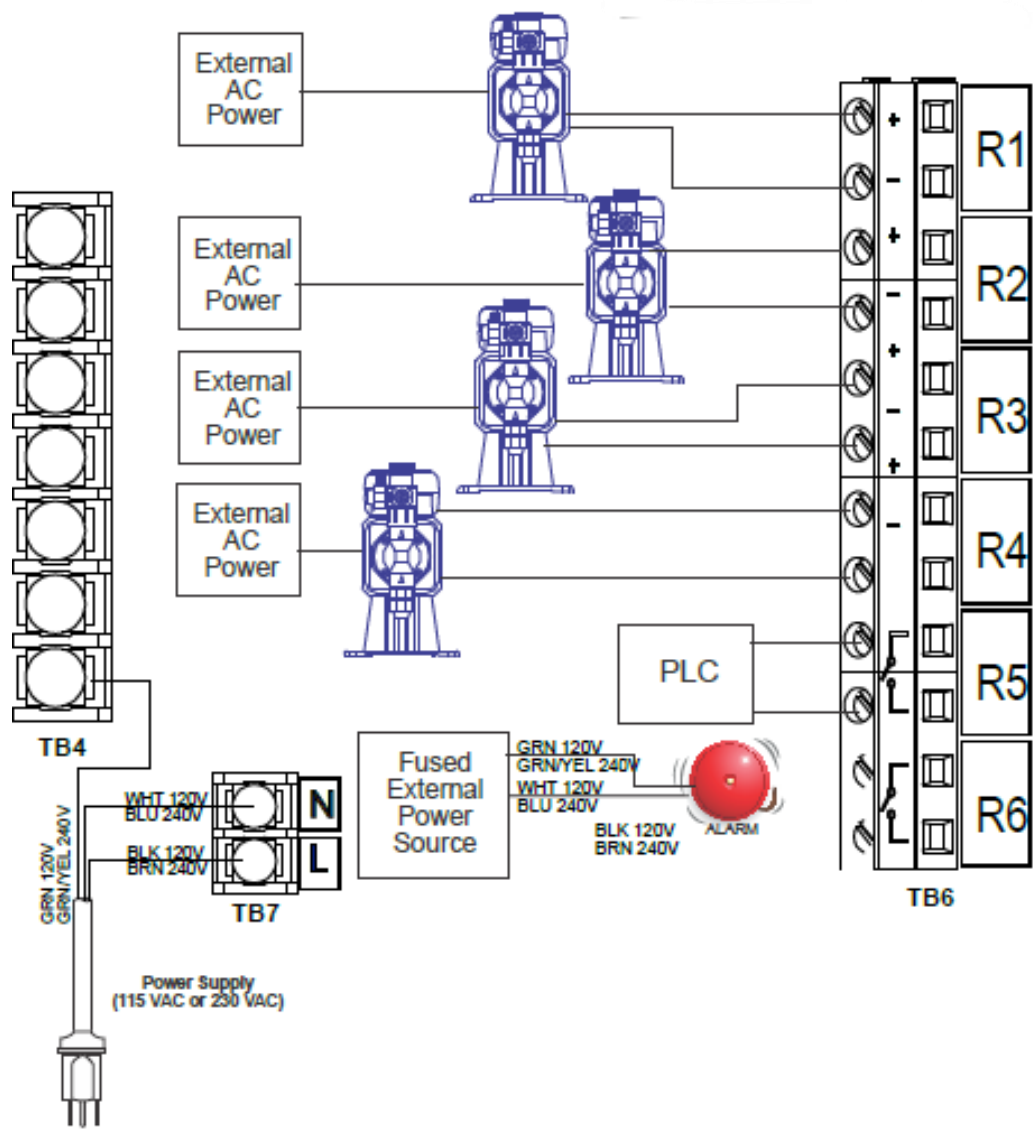

Figure 17 W640 AC Power & Relay Output Wiring

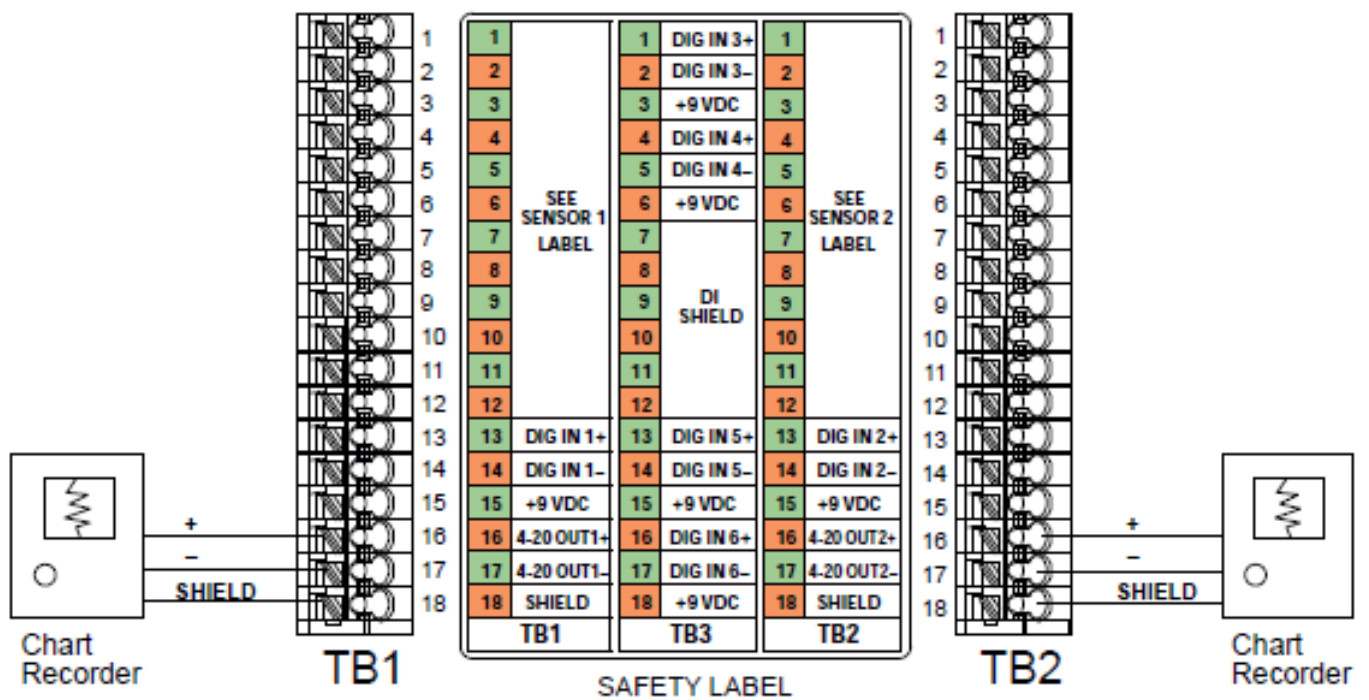

Figure 18 Analog Output Wiring