

RT-100 PRISM

Inline Digital Refractive Index / % Glycol Sensor / % BRIX

Product Description

The Pyxis RT-100 Prism is an inline digital refractometer that measures the refractive index of a liquid sample and provides a direct reading of highly accurate concentration values for a wide variety of water and process related applications. It is a stand-alone device capable of self-sustained operation, live data display and data logging. The RT-100 Prism also offers fully integrated 4-20mA and RS-485 Modbus output signals for connectivity to any microprocessor-based controller, display, PLC or DCS network. The RT-100 Prism has built-in temperature dependent equations to convert the measured sample temperature and refractive index to the percentage concentration of Mono Ethylene Glycol (MEG), Mono Propylene Glycol (MPG), Sugar Content (Brix) and Advanced Low Viscosity Fluid (ALV). Additional concentration curves may be added in the future by Pyxis Lab as the market demands.

The RT-100 Prism is a very robust, digital sensor and is capable of operating in contaminated fluid samples. It is important however to note that users should take all precautions to mitigate and filter suspended solids from the sample stream prior to the sensor to avoid tenacious deposit build-up on the sensor eye. In highly fouled applications, Pyxis recommends users conduct sensor eye cleaning on a regular basis per the manual guidelines. Pyxis Lab is also developing will be launching an automated sensor cleaning accessory for installation into the Tri-Clamp Flow Cell assembly as an optional accessory in the near future.

Typical Applications

- Refractive Index Direct Read for Process Applications
- Mono-Ethylene Glycol Closed Loop System Monitoring
- Mono-Propylene Glycol Closed Loop System Monitoring
- Brix/Sugar Concentration Process Applications
- Advanced Low Viscosity Fluid Heat Transfer Fluid
- Specific Gravity Determination via Refractive Index



Figure 1. RT-100 Prism – Inline Refractometer



Figure 2
RT-100 Prism Installed in Tri-Clamp Flow Cell Assembly

Features

- 4-20 mA output of sample temperature and the unit of display selected via the screen interface
- RS-485 Modbus RTU output of temperature, refractive index and other diagnosis parameters
- Built-in temperature dependent equations % BRIX, %MPG, %MEG and % ALV
- Future Addition of Product Concentration Curves by Pyxis as Market Requests
- Local Display and Push-Button Interface
- Optional 110VAC – 24 VDC Wall Outlet Powered for Independent Operation w/out controller
- Built-In Historical Data Log up to 56 Days of Storage at 1 Reading Per Minute via uPyxis APP
- Bluetooth Enabled when used with MA-CR Bluetooth Adapter
- Sturdy 316L stainless-steel construction and suitable for harsh application environments
- Convenient Stainless-Steel Tri-Clamp Flow Cell Assembly w ¾-inch NPT Flange
- Easy Installation and Removal for Cleaning and Maintenance – No Tools Needed

Specifications

ITEM	RT-100 Prism
P/N	55105
Range of Measurement	Refractive Index: 1.31700 – 1.5100 Brix: 0.00 – 85.00% Mono Ethylene Glycol: 0.00 – 100.00% Mono Propylene Glycol: 0.00 – 100.00% Advanced Low Viscosity Fluid: 0.00 – 100.00% Temperature: -20°C – 80°C
Resolution	Refractive Index: 0.0001 Brix and Glycol: 0.1%
Accuracy	Refractive Index: ±0.0002 Brix and Glycol: ±0.2%
Sample Temperature	-4 – 158 °F (-20 – 70 °C)
Max Sample Pressure / Flow	≤142 psi (0.98 MPa) / <13.5 GPM (9.8 ft/s)
Environmental Temperature	14 – 104 °F (-10 – 40 °C)
Weight	6.2 pound (2.8 kg)
Dimension	4.33 x 4.57 inch (110 x 116 mm)
Protection	IP-67
Light Source	LED
Wet Materials	Sapphire, 316L Stainless steel
Signal Output	2x 4-20 mA and RS-485 Modbus
Power	24 VDC (1.5W)
Regulation	CE / RoHS Marked

Pyxis Lab is constantly updating technology, as such specifications are subject to change

RT-100 Prism Package (P/N 55105)

- The package should include one RT-100 Prism Refractive Index Sensor w/8Pin Female Cable
- One 316L Stainless Steel Tri-Clamp Flow Cell Assembly for RT-100 (P/N 56206)
- One MA-1.5CR Cable (1.5 Meter/ 4.9 ft 8Pin Male Adapter/Flying Lead) (P/N 50746)



Figure 3 - RT-100 Prism Inline Refractometer / Tri-Clamp Flow Cell Assembly for RT-100 / MA-1.5 Flying Lead Cable

RT-100 Prism Optional Accessories – Purchased Separately

Optional Accessories	P/N
RT-100 Prism Wall Outlet Power Supply Adapter Kit <i>(Plug In Power Supply Kit - Converts Wall Outlet 110VAC to 24VDC for Prism RT-100 – 2Pin)</i>	56207
MA-CR <i>(Bluetooth Adapter for 8-Pin Pyxis Sensors for use with uPyxis Mobile & Desktop)</i>	MA-CR
MA-NEB <i>(USB Bluetooth Adapter for PC to use uPyxis Desktop)</i>	MA-NEB
MA-50CR (50' Extension Cable w/8Pin Adapters)	50743
Pyxis Probe Cleaning Kit	SER-01
RT-100 Prism Tri-Clamp Flow Cell Assembly Complete Replacement	56206
RT-100 Prism Tri-Clamp Flow Cell Replacement Gasket Kit	56209

RT-100 Prism Dimensions (mm)

Unit: mm

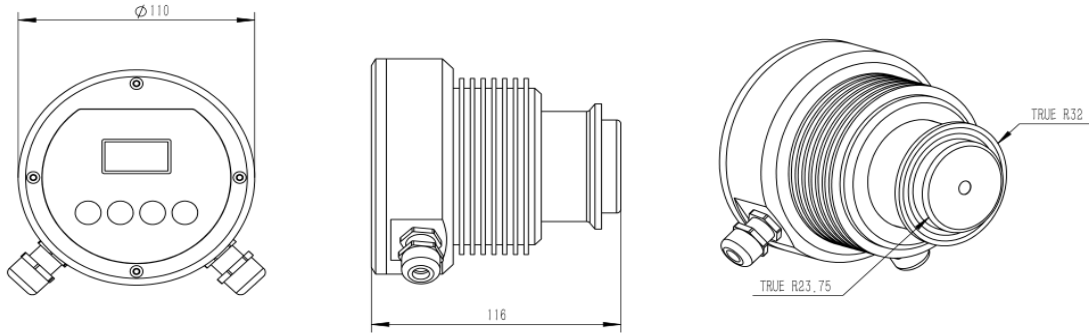

RT-100 Tri-Clamp Flow Cell Components (included with each RT-100 Purchase)

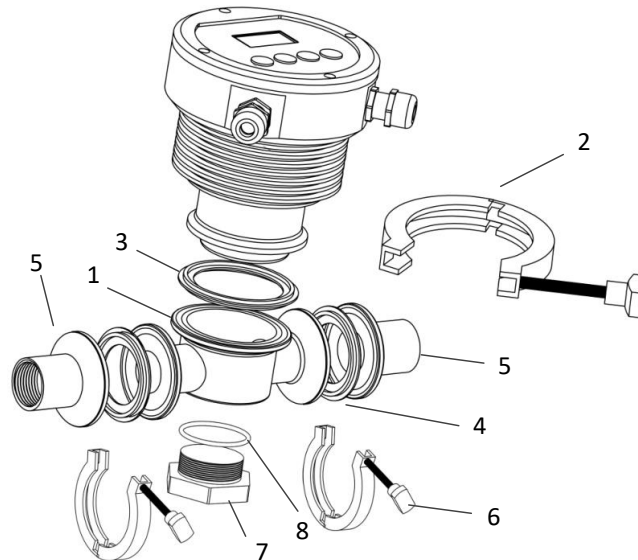

ITEM	ID #	DESCRIPTION	P/N
RT-100 PRISM TRI-CLAMP FLOW CELL ASSEMBLY	1	Flow cell with 2.5-inch Port for Prism RT-100 Sensor Head	56206
	2	Prism RT-100 Sensor Tri-Clamp 2.5-inch	
	3, 4, 8	Tri-Clamp Flow Cell Gasket Kit (PN:56209)	
	5	3/4 inch FNPT Flange	
	6	Flange Tri-Clamp 2-inch	
	7	Threaded Plug for Cleaning Device Install	

Prism RT-100 Tri-Clamp Flow Cell Assembly

uPyxis APP Diagnosis, Calibration and Historical Data Transfer

The uPyxis APP manages all Pyxis portable meter and inline sensors on mobile and desktop devices, including Apple iPhones and Samsung Android smartphones. When connected to the Pyxis RT-100 Prism, the uPyxis APP enables users to diagnose, air-calibrate Refractive Index value, Off-Set Calibrate Liquid Concentrations to Refractive Index Value, Restore Factory Settings, Transfer Historically Logged Data and View Live Sensor Refractive Index and Temperature Data Trends. For wireless access to RT-100, the MA-CR Bluetooth Adapter will be required and should be purchased as an optional accessory. ***Note*** The uPyxis Mobile APP is evolving rapidly and users can find the latest version at no cost on Apple iStore or Google Play. The uPyxis Desktop APP may be downloaded at <https://pyxis-lab.com/support-2/>

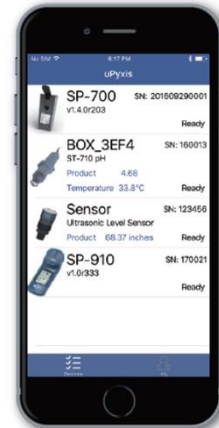

Order Information

RT-100 Prism – Inline Refractometer <i>(Includes Tri-Clamp Flow Cell Assembly and Flying Lead Cable)</i>	P/N 55105
--	--------------

Optional Accessories Information

RT-100 Prism Wall Outlet Power Supply Adapter Kit <i>(110VAC to 24VDC Power Supply – 2 wire)</i>	56207
MA-CR Bluetooth Adapter <i>(8Pin Adapter Enables Wireless Calibration w/uPyxis APP)</i>	MA-CR
MA-NEB <i>(USB Bluetooth Adapter for PC to use uPyxis Desktop)</i>	MA-NEB
MA-50CR <i>(50ft Extension Cable w/8Pin Adapters)</i>	50743
Pyxis Probe Cleaning Kit	SER-01
RT-100 Prism Tri-Clamp Flow Cell Assembly Complete Replacement	56206
RT-100 Prism Tri-Clamp Flow Cell Replacement Gasket Kit	56209