

## pH/ORP PREAMPLIFIER INSTALLATION AND WIRING P/N 191949

### ■ MOUNTING

- Two mounting holes are under enclosure cover
- Mount enclosure using two #6 screws (not provided)

### ■ PROPER SHIELDING METHODS

Proper shielding and grounding of the signal wires is critical to obtaining a stable reading. Use only 24 AWG shield twisted pair cable to connect the preamp to the controller.

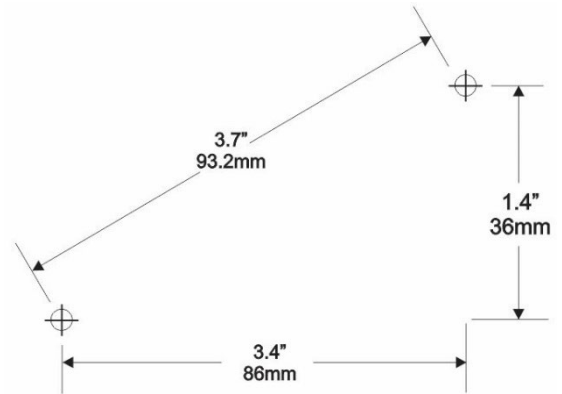

*If your pH/ORP electrode does not have a solution ground wire*

Or

*If your pH/ORP electrode has a solution ground wire and immersed in a non-grounded solution:*

Connect the shield drain wire to both the TC GND terminal in the preamp and the ground stud inside the enclosure of the controller, as shown below.

*If your pH/ORP electrode has a solution ground wire and immersed in a grounded solution:*

Connect the shield drain wire only to the TC GND terminal in the preamp.

### ■ WIRING TO A WALCHEM CONTROLLER

Preamp Terminal	W100/600/900	WebMaster/W400	W300
TEMP +	TEMP +	T+	TC+
TEMP -	TEMP -	T-	TC-
SHEILD	Ground Terminal	Ground Stud	Ground Stud
+5V	+5V	+5	+5V
-5V	-5V	-5	-5V
IN -	IN-	IN -	COM
IN +	IN+	IN +	pH

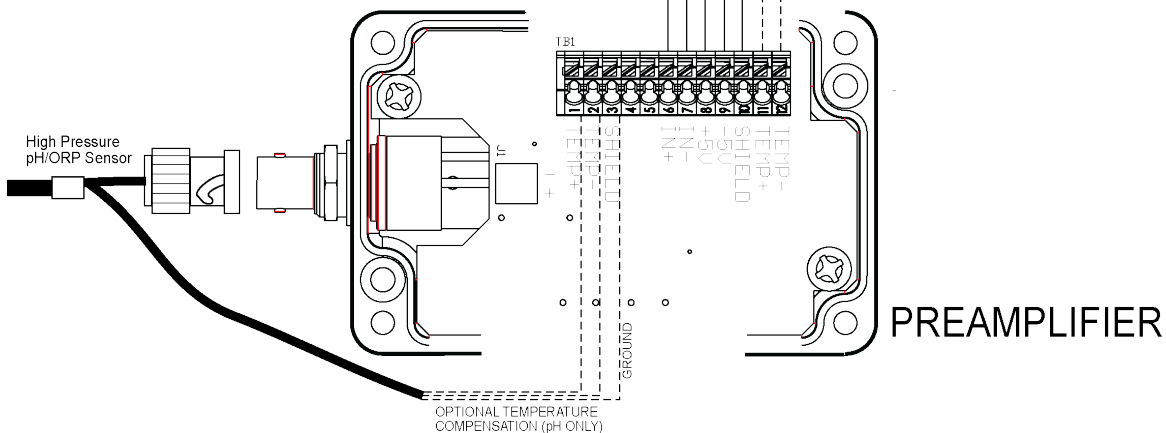

## pH/ORP PREAMPLIFIER INSTALLATION AND WIRING P/N 191936 and 191938

### ■ MOUNTING

Must be installed inside the controller's enclosure to be protected from water and dust.  
For 191936, use a booted BNC on the sensor to prevent short circuit damage to the controller.

### ■ WIRING

The preamp cable unplugs from the preamp to make wiring easier.

### PREAMP CABLE TO CONTROLLER

Preamp Cable	W100/600/900	WebMaster/W400	W300
+5V (RED)	+5V	+5	+5V
-5V (BLK)	-5V	-5	-5V
IN- (WHT)	IN-	IN-	COM
IN+ (GRN)	IN+	IN+	pH

### SENSOR CABLE TO PREAMP

#### 191936

Attach the pH/ORP/Ion Selective Electrode with booted BNC connector to the preamp BNC connector by pushing the connectors together and engaging with a quarter turn. If the BNC is not booted, precautions must be taken to ensure that the metal connector is not able to touch any electronic components inside the controller!

#### 191938

Attach the tinned leads from the pH/ORP/Ion Selective Electrode. The inner conductor of the coaxial cable connects to the + terminal of the preamp, and the outer shield of the coaxial cable connects to the – terminal of the preamp. The terminal labels are molded into the preamp plastic housing adjacent to the terminal block.

### SPECIFICATIONS

	191949	191938	191936
Power	$\pm 5$ VDC ( $\pm 10\%$ ) 3 mA maximum		
Input Impedance	$1 \times 10^{13}$ ohms		
pH/ORP/ISE Input Connections	BNC	Two position terminal block	BNC
Temperature Input Connections	Three position terminal block	Not Applicable	
Output Connections	Six position terminal block	Four position connector, prewired with 5" cable	
Enclosure	NEMA 4X/IP 65 glass reinforced polyamide wall mount with PG11 cable glands	Non-NEMA rated Nylon 12 – needs to be installed inside the controller. For 191936, use a booted BNC on the sensor to prevent short circuit damage to the controller.	
Dimensions	4.5"L x 3.3"W x 1.3" H 115 mm x 84 mm x 34 mm	2.0"L, 0.79"W, 0.64"H 51 mm x 20 mm x 16 mm	2.0"L, 0.79"W, 1.01"H 51 mm x 20 mm x 26 mm