

190809/190820 Option Board Installation

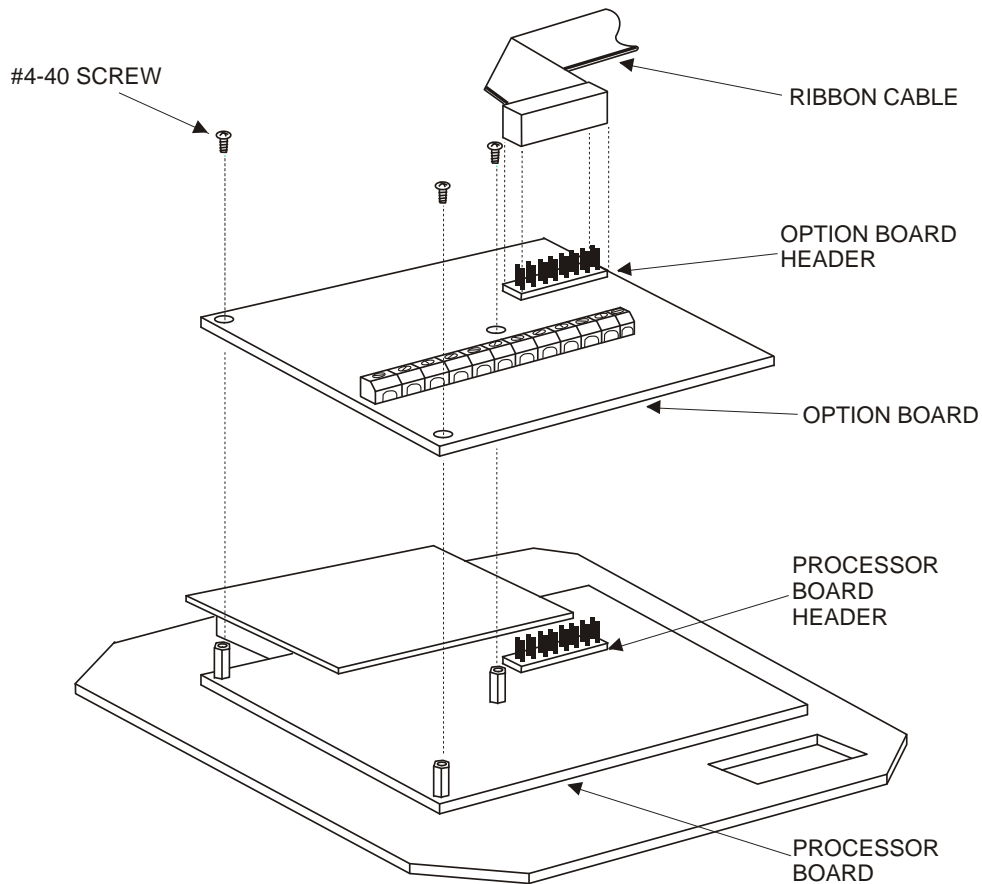

Caution! Are live circuits inside the controller even when the power switch on the front panel is turned OFF. The front panel should never be opened before power to the controller is removed.

1. Remove the Ribbon Cable from the Processor Board Header.
2. Carefully place Option Board onto Processor Header Board. *Note: Ensure header and receptacle are aligned correctly.*
3. Using three screws (#4-40 x 3/16"), fix Option board to Processor.
4. Reattach Ribbon Cable Receptacle to Option Board Header in the same orientation as removed (as shown).
5. Installation is complete. Close/fasten cover and power up unit.
6. Refer to Controller Instruction Manual for programming and set-up.

WIRING

