

## ELECTROLESS NICKEL SAMPLE SYSTEM

Designed to be used in conjunction with Walchem's WNI Series electroless nickel controllers, this sample system makes installation a snap. All system components are preconnected and mounted in an all thermoplastic enclosure.

The unit is wall mounted and tubing and electrical is guided through the bottom panel of the unit. A convenient plexiglass window allows visual inspection of components without having to open the enclosure. Stainless steel latches are lockable for security if necessary.



## SUMMARY OF KEY BENEFITS

- » Convenient wall mount package for all components required for Nickel and pH control
- » Standard process connections
- » Includes 20 ft. of sample tubing
- » Sample pump preset for 500 ml/minute flow rate
- » Compact and neat

## TYPICAL INSTALLATION

## DIMENSIONS

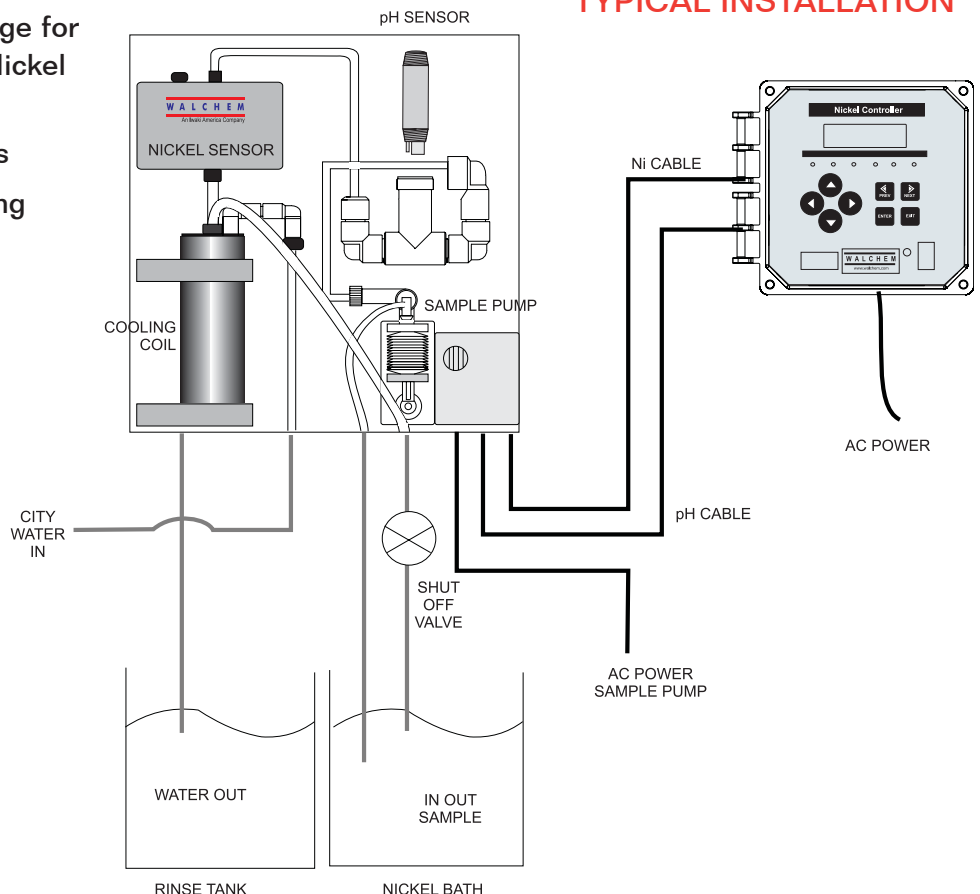
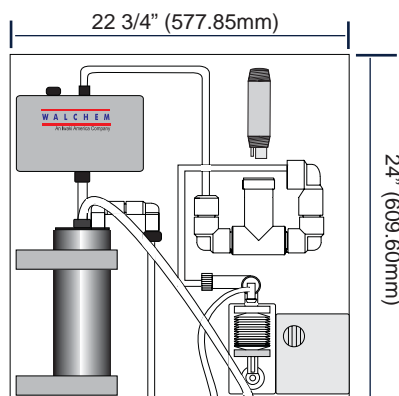

## ORDER INFORMATION

190921 System, WNI Sample, 115 VAC, 60 Hz  
190922 System, WNI Sample, 230 VAC, 50 Hz

## SPECIFICATIONS

**Power** 115VAC, 60 Hz  
230VAC, 50 Hz

**Mechanical Enclosure** Polypropylene with plexiglass window

**NEMA Rating** None

**Dimensions** 22 3/4" (W) x 24" (H) x 7 1/4" (D)  
**Shipping Weight** 45 lbs (approx.)

**Sensor Cables** 20 ft. standard, 80 ft. max.

**Nickel sensor connector** Custom for WNI controller  
**pH Electrode connector** Tinned leads

**Sample Temperature** 140°F (60°C) maximum

**Sample Process connections** 3/8" OD tubing connector

**Cooling water connections** 1/2" NPTF

**Sample flow rate** 500 ml/minute  
**Cooling water flow rate** 2 gpm minimum



### WebmasterONE®

WebMasterONE® is the most powerful online cooling tower/boiler controllers in the water treatment industry. WebMasterONE® couples a multi-I/O platform with Walchem's analytical sensors and extensive communications technologies. The result is the ability to remotely monitor and control your process from any computer, anywhere in the world, with just a standard web browser.



### WIND WebMaster Industrial Water Controllers

Walchem's WebMaster® Industrial (WIND) Controller sets a new standard for Industrial Water Treatment Controllers. WIND has a flexible multi-I/O platform, a wide range of analytical sensor measurement capabilities, and an extensive assortment of integrated communications and data handling features.



### Metering Pumps

Walchem and Iwaki combined their talents to design the most innovative and comprehensive metering pump product line in the world. With over 50 years of combined pump experience, in an array of different markets, the Iwaki-Walchem partnership leverages our strengths to exceed even our toughest customer expectations. Committed to new product development, our pumps are innovative and revolutionary.



### WebAlert Remote Monitor

Walchem's WebAlert is the first stand alone remote monitoring device that can web enable your installed equipment without having to replace or upgrade it.

## ABOUT US

Walchem integrates its advanced sensing, instrumentation, fluid pumping and communications technologies to deliver reliable and innovative solutions to the global water treatment market

Our in-house engineering is driven by quality, technology and innovation. For more information on the entire Walchem product line, visit: [www.walchem.com](http://www.walchem.com)



Walchem, An Iwaki America Incorporated Company  
Five Boynton Road Hopping Brook Park  
Holliston, MA 01746 USA  
Phone: 508-429-1110  
Fax: 508-429-7433  
[www.walchem.com](http://www.walchem.com)