

TRI-PURPOSE VALVE - THREE VALVES IN ONE

- » **Anti-Syphon Valve**
Enables feeding into suction/negative pressure applications or metering fluids “downhill”
- » **Back Pressure Valve**
Provides accurate metering of fluids into low or open discharge pressures
- » **Pressure Relief Valve**
Adjustable between 30 psi and 125 psi

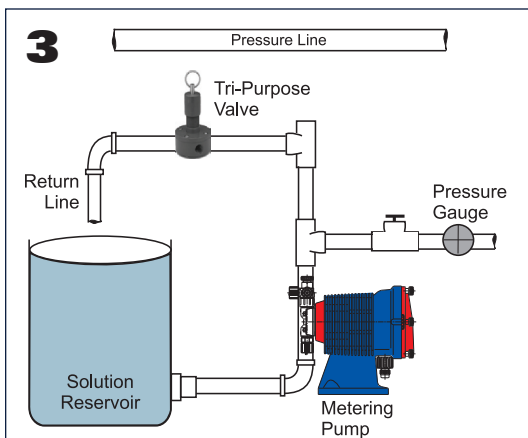
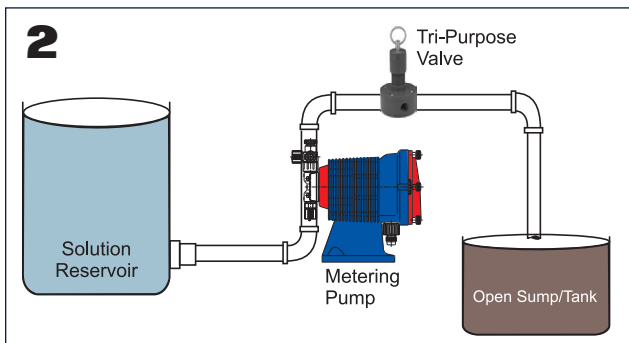
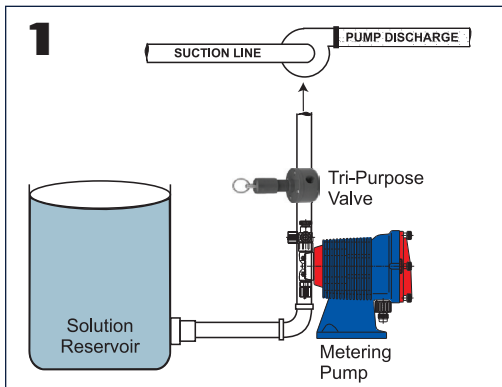

Anti-Syphon Valve

The Tri-Purpose Valve can be installed as an anti-syphon valve to prevent syphoning fluid through a metering pump or other feeding system where the liquid is being fed into negative pressure. The greater the negative pressure, the tighter the diaphragm seats. Install with the flow direction as shown on data plate on base of valve.

Back Pressure Valve

The Tri-Purpose Valve can also be installed so as to require a metering pump or other injection device to develop a positive pressure in order to feed through it. The opening pressure is approximately 30-40 PSI which is useful for feeding or metering into an open tank or reservoir located at a level below the supply tank. As a back pressure valve, it should be installed so that the flow direction is the same as the direction of the flow when used as an anti-syphon valve. See data plate on base of valve.

Pressure Relief Valve

The Tri-Purpose Valve is an excellent pressure relief valve which can be adjusted after installation to any desired pressure between 30 PSI (2.1 kg/cm²) and 125 PSI (8.8 kg/cm²).

When used as a pressure relief valve, the Tri-Purpose Valve is installed on the branch of a tee whose run is in the pressure line.

Flow direction through the valve when used as a pressure relief valve is 180° opposite the anti-syphon and back pressure flow direction. See data plate on base of valve.

ORDER INFORMATION

8011-C PVC/Teflon®
 8011-CP Polypropylene/Teflon®

SPECIFICATIONS

1/2" NPT Connections/Tubing

The Walchem Tri-Purpose Valve may be installed horizontally or vertically. All parts except the body may be serviced or replaced without removing the valve from the line.

NOTE: Do not use on systems exceeding 150 PSI.

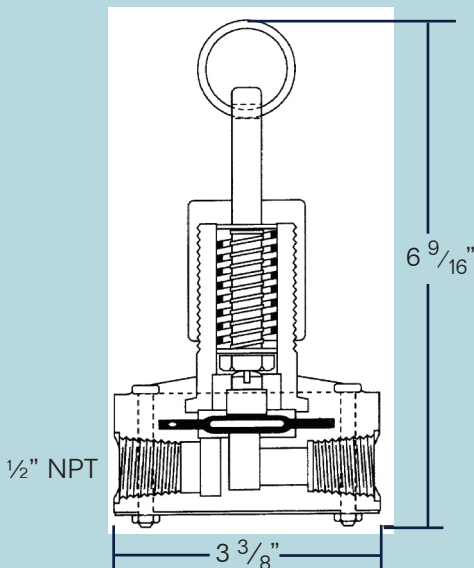
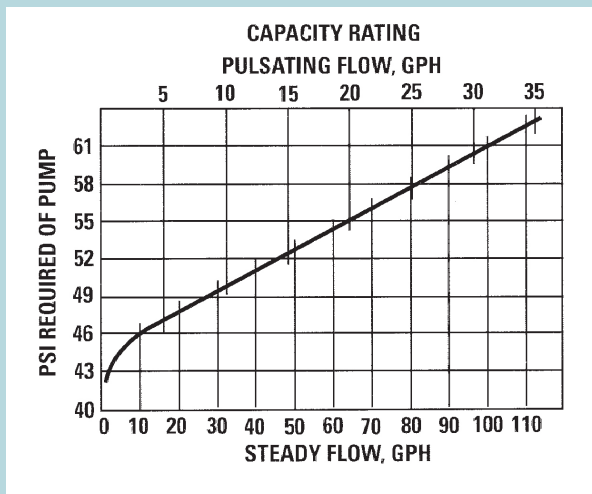

WebmasterONE®

WebMasterONE® is the most powerful online cooling tower/boiler controllers in the water treatment industry. WebMasterONE® couples a multi-I/O platform with Walchem's analytical sensors and extensive communications technologies. The result is the ability to remotely monitor and control your process from any computer, anywhere in the world, with just a standard web browser.



Metering Pumps

Walchem and Iwaki combined their talents to design the most innovative and comprehensive metering pump product line in the world. With over 50 years of combined pump experience, in an array of different markets, the Iwaki-Walchem partnership leverages our strengths to exceed even our toughest customer expectations. Committed to new product development, our pumps are innovative and revolutionary.



WIND WebMaster Industrial Water Controllers

Walchem's WebMaster® Industrial (WIND) Controller sets a new standard for Industrial Water Treatment Controllers. WIND has a flexible multi-I/O platform, a wide range of analytical sensor measurement capabilities, and an extensive assortment of integrated communications and data handling features.



WebAlert Remote Monitor

Walchem's WebAlert is the first stand alone remote monitoring device that can web enable your installed equipment without having to replace or upgrade it.

ABOUT US

Walchem integrates its advanced sensing, instrumentation, fluid pumping and communications technologies to deliver reliable and innovative solutions to the global water treatment market

Our in-house engineering is driven by quality, technology and innovation. For more information on the entire Walchem product line, visit: www.walchem.com



WALCHEM

An Iwaki America Company

Walchem, An Iwaki America Incorporated Company
 Five Boynton Road Hopping Brook Park
 Holliston, MA 01746 USA
 Phone: 508-429-1110
 Fax: 508-429-7433
www.walchem.com