

## 102028 IN-LINE MOUNTING GLAND, STAINLESS STEEL HIGH TEMPERATURE AND PRESSURE

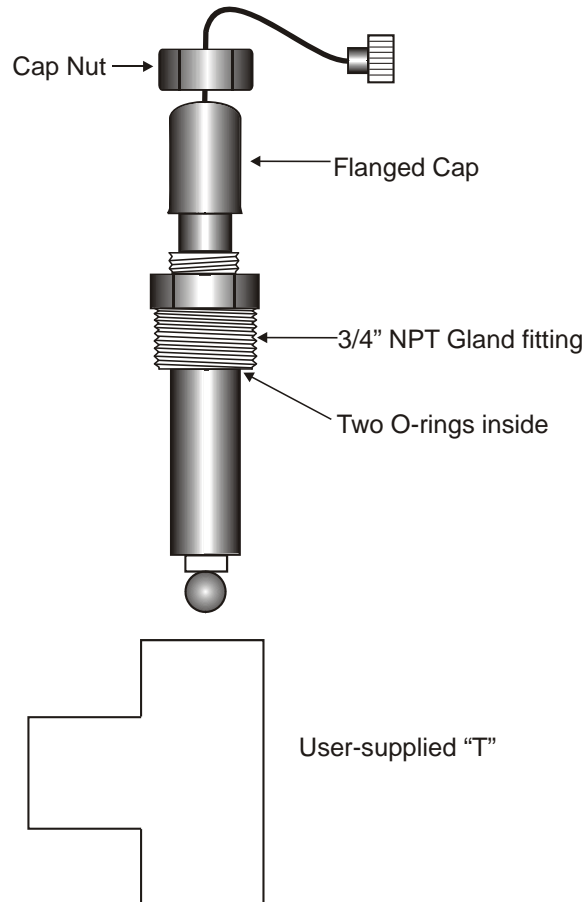

1. While process line is not under any pressure, install the gland in a 3/4" NPT "T" fitting.
2. Use only an ISI electrode with a stainless steel flanged cap.
3. Lubricate both O-rings and install the Viton® O-ring between the electrode cap and the top of the gland fitting.
4. Install the cap nut over the top of the electrode cap and then **HAND TIGHTEN ONLY**.